

TECHNICAL MANUAL

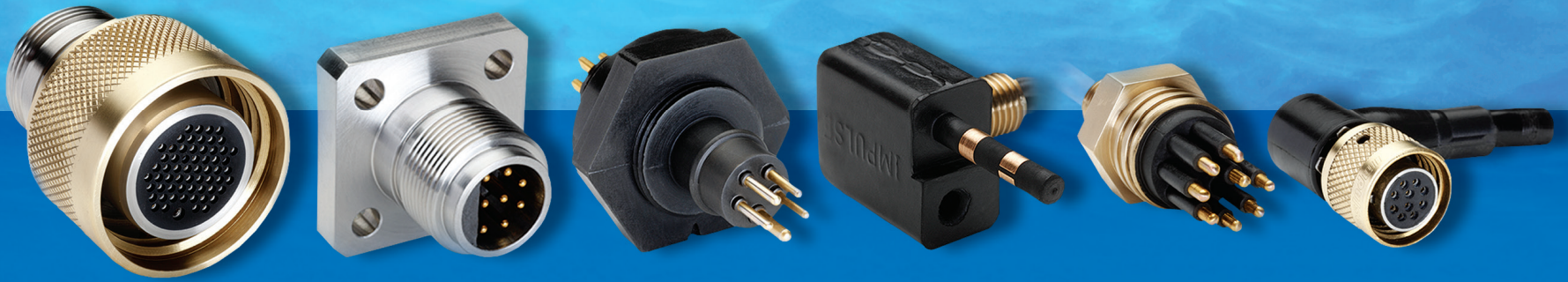

MAKING CONNECTIONS IN HARSH ENVIRONMENTS



TELEDYNE IMPULSE

INTERCONNECT SOLUTIONS

PRODUCTS AND SERVICE

We at Teledyne Impulse have set our standards high to meet the needs and requirements of you, our valued customer.

Teledyne Impulse products and services include the following:

- Thermoset Glass Reinforced Epoxy Connectors
- Rubber Molded Connectors
- Rubber Molded Metal Shell Connectors
- Polyurethane Molded Connectors
- Metal Shell Connectors
- Pressure Balanced Oil Filled Connectors
- Magnetically Operated Proximity Switches
- Cable Termination
- Neoprene and Polyurethane Cable Splicing to Connectors
- Custom Breakouts
- Custom Connector Design and Fabrication
- Turnkey Solutions

Quality products, on time delivery, very competitive prices and excellence in CUSTOMER SERVICE are vital differences created at Teledyne Impulse.

At Teledyne Impulse we gear all our efforts to one simple conclusion:

CUSTOMER SATISFACTION

THIS PAGE INTENTIONALLY LEFT BLANK

GENERAL INFORMATION

TABLE OF CONTENTS

<u>SECTION</u>	<u>PAGE</u>
GENERAL INFORMATION	
PRODUCTS & SERVICES	A
TABLE OF CONTENTS	B
GENERAL SPECIFICATIONS	C
SALES OFFICE LOCATIONS	D
TERMS AND CONDITIONS OF SALE	E
BREAKOUTS, SPLICES, T-MOLDS	10 01
RUBBER/POLYURETHANE MOLDED INLINE, GLASS REINFORCED EPOXY	20 01
INVERTED RUBBER/POLYURETHANE MOLDED INLINE, INVERTED GLASS REINFORCED EPOXY	25 01
GLASS REINFORCED EPOXY SERIES	30 01
METAL SHELL SERIES	45 01
METAL SHELL PRESSURE BALANCED OIL FILLED (PBOF) SERIES	50 01
PENETRATORS	55 01
WET PLUGGABLE	65 01
MINI WET PLUGGABLE	65 80
MCIL/BH/OM MICRO MINI WET PLUGGABLE	65 109
MCIL/BH (WB) MICRO MINI WET PLUGGABLE	66 01
IE55 RUBBER MOLDED METAL SHELL SERIES	70 01
IE55V INVERTED RUBBER MOLDED METAL SHELL SERIES	71 01
IE UNDERWATER PLUGGABLE	75 01
IEB-6/8-LOCKING SLEEVES	75 61
IE UNDERWATER PLUGGABLE SERIES 3	75 70
PROXIMITY SWITCHES/MAGNETICALLY OPERATED	80 01
MINIATURE HIGH DENSITY METAL SHELL SERIES	85 01
MINIATURE HIGH DENSITY METAL SHELL SERIES-OIL FILLED	86 01
METAL KEY TITAN™SERIES	95 01
GLOSSARY	V
INDEX	X

THIS PAGE INTENTIONALLY LEFT BLANK

GENERAL INFORMATION

GENERAL SPECIFICATIONS

CONTACT CURRENT CAPACITY AND DIMENSIONS

(Current capacities shown are for single contact only and do not reflect connector or cable current capacity.)

AMERICAN WIRE GAUGE (AWG)	AMP/CAPACITY	DIA/INCHES	MM ²
#1/0 AWG	200	.355	65.8
#4 AWG	65	.255	31.7
#6 AWG	55	.218	24.1
#8 AWG	40	.156	12.3
#10 AWG	25	.125	7.9
#12 AWG	20	.110	6.1
#14 AWG	15	.093	4.4
#16 AWG	12	.062	1.9
#20 AWG	3	.038	0.73
#22 AWG	2	.031	0.48

HEX DIMENSIONS

DIMENSION ACROSS FLATS	APPROX OVERALL DIAMETER	DIMENSION ACROSS FLATS	APPROX OVERALL DIAMETER
.37	.43	1.25	1.45
.62	.73	1.375	1.59
.75	.87	1.50	1.73
.875	1.02	1.625	1.88
.90	1.04	1.75	2.02
1.00	1.16	2.00	2.31
1.12	1.30	2.50	2.89

RIGHT ANGLE CONNECTOR INDEXING

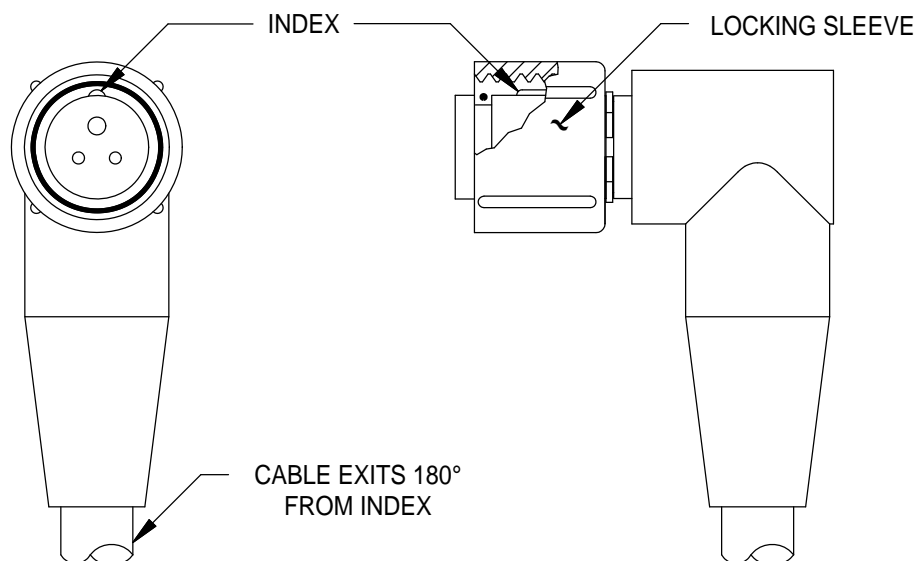

GENERAL INFORMATION

TELEDYNE IMPULSE OFFICES

USA-HEADQUARTERS

Teledyne Impulse
9855 Carroll Canyon Rd.
San Diego, CA 92131
Tel: +1-858-842-3100
Fax: +1-858-565-1649
E-Mail: impulse@teledyne.com
Web: www.teledyneimpulse.com

EUROPEAN HEADQUARTERS

Teledyne Impulse-PDM
4-6 Alton Business Centre
Omega Park
Alton, Hampshire GU34 2YU
United Kingdom
Tel: +44(0)1420-85848
Fax: +44(0)1420-84288
E-Mail: pdmsales@teledyne.com
Web: www.teledyneimpulse-pdm.com

TELEDYNE OIL & GAS

Teledyne Impulse
835 Greens Parkway Suite 100
Houston, Texas 77067
Tel: +1-281-875-1717
Fax: +1-281-875-6161
E-Mail: impulse@teledyne.com
Web: www.teledyneimpulse.com

TELEDYNE IMPULSE REPRESENTATIVES AND DISTRIBUTORS USA

MA/ME/NH/RI/VT:

OGI
1 Magnusson Ct.
E. Sandwich, MA 02537
Tel: 508-888-4510
Fax: 508-888-4509
E-Mail: pigo57@aol.com
Web: www.oginstruments.com

CT/NJ/NY/PA:

OGI
24 Pond St.
Uxbridge, MA 01569
Tel: 508-566-3140
E-Mail: dross.ogi@charter.net
Web: www.oginstruments.com

D.C./DE/MD/VA:

Lindgren Associates, Inc.
8711 Plantation Lane
Manassas, VA 20110
Tel: 703-330-5666
Fax: 703-330-2440
E-Mail: Phil@LindgrenAssociates.com
Web: www.lindgrenassociates.com

AL/FL/GA/LA/MS/TX:

Abtel Universal Technology, Inc.
4403 Sanctuary Halls
Spring, TX 77388
Tel: 713-389-5208
Fax: 713-389-5207
E-Mail: [sales@abteluniversal
technology.com](mailto:sales@abteluniversaltechnology.com)
Web: [www.abteluniversal
technology.com](http://www.abteluniversal
technology.com)

TELEDYNE IMPULSE REPRESENTATIVES AND DISTRIBUTORS USA (continued)

AZ/CA/ID/NV/OR/UT/WA:

GTS Consulting, Inc.
2726 Shelter Island Dr., Suite 245
San Diego, CA 92106
Tel: 858-405-5810
Fax: 619-342-2332
E-Mail: steven@gts-consulting.com
Web: www.gts-consulting.com

ASIA

JAPAN:

Impulse Corporation
Someya Bldg 4F
3-1-8, Kitakashiwa, Kashiwa City
Chiba-ken, Japan 277-0832
Tel: +81-47-133-5433
Fax: +81-47-134-9483
E-Mail: impulse@j-impulse.co.jp
Web: www.j-impulse.co.jp

MALAYSIA:

Teledyne Malaysia
Teledyne Technologies Asian, Inc.
No. J-03-2, Dataran Glomac,
Jalan SS6/18, Kelana Jaya, 47301
Petaling Jaya, Selangor, Malaysia
Tel: 603-7805 7712/13/14
Fax: 603-7805 7710
E-Mail: David.ooi@teledyne.com
Web: www.teledyneoilandgas.com

SINGAPORE:

Precision Technologies Pte. Ltd.
211, Henderson Road #13-02
Henderson Industrial Park
Singapore 159552
Tel: +65-6273-4573
Fax: +65-6273-8898
E-Mail: aeddonchua@pretech.com.sg
E-Mail: milaero6@pretech.com.sg
Web: www.pretech.com.sg

SOUTH KOREA:

NextStep Co. Ltd.
23-4 Industrial Material Town
16, Yutongdanji-ro, Buk-gu,
Daegu, 41518 Korea
Tel: +82-53-6043040
E-Mail: johny@nstep.co.kr
Web: www.nstep.co.kr

CHINA:

SmartSea Technology Co. Ltd.
Room 403-404, United Creative Building East Tower
No. 901, Yin Xiu Road, Wuxi, China Post Code: 214072
Tel: +86-(0)-510-8588 5556 / 8588 0495 / 8588 0496
E-Mail: tony.yao@smartseatech.com
Web: www.smartseatech.com & www.smartseaintl.com

CHINA:

Geo Marine Technology Ltd.
Rm 102, Building 22, No. 518 XinZhuan Rd,
SongJiang District, Shanghai, 201612
Tel: 021-54970635
Fax: 021-54970091
E-Mail: fanny@geo-marine-tech.com
Web: www.geo-marine-tech.com.cn

SeaTech China Co. Ltd.
Rm 309, Chuang Xin Da Sha, Tian An Ke Ji Yuan
No. 5555, Panyu Dadao Bei, Panyu
Guangzhou, P.R. China Post Code: 511430
Tel: +86 020-39388496, 39388473 ext: 614
Mobil: +86 15622199679
E-Mail: hgb@seatechchina.com

AUSTRALIA

UVS Pte. Ltd.
Unit 1, 41 Discovery Drive,
Bibra Lake, W.A. 6163, Australia
Tel: +61-8-6595 1505
E-Mail: lynn.needham@uvs.com.au
Web: www.bluezonegroup.com.au

TELEDYNE IMPULSE REPRESENTATIVES AND DISTRIBUTORS BRAZIL

Teledyne ODI Brasil
(formely Ocean Design Ltda.)
Rua Mem de Sá, 34 salas 1203/4/5
24220-261 Niterói, Rio de Janeiro Brazil
Tel: +55 21 2714-6072
E-Mail: mpainter@teledyne.com
Web: www.teledyneoilandgas.com

CANADA

Nova Scotia/Prince Edward Island/
New Brunswick/Newfoundland:

ROMOR Ocean Solutions
41 Martha Avenue,
Mt. Uniacke Business Park
Mt. Uniacke, NS
B0N 1Z0 Canada
Tel: 902 466-7000
Fax: 902 466-4880
E-Mail: sales@romor.ca
Web: www.romor.ca

British Columbia:

GTS Consulting, Inc.
2726 Shelter Island Dr., Suite 245
San Diego, CA 92106
Tel: 858-405-5810
Fax: 619-342-2332
E-Mail: steven@gts-consulting.com
Web: www.gts-consulting.com

EUROPE

Teledyne Impulse-PDM
4-6 Alton Business Centre
Omega Park
Alton, Hampshire GU34 2YU
United Kingdom
Tel: +44-1420-85848
Fax: +44-1420-84288
E-Mail: pdmsales@teledyne.com
Web: www.teledyneimpulse-pdm.com

NEW ZEALAND

Zebra-Tech Ltd.
P.O. Box 1668
Nelson, New Zealand
Tel: +64 (3) 548-0468
Fax: +64 (3) 548-0466
E-Mail: inquiry@zebra-tech.co.nz
Web: www.zebra-tech.co.nz

TERMS AND CONDITIONS OF SALE

1. DEFINITIONS

"Seller" means Teledyne Impulse, a business unit of Teledyne Instruments, Inc. "Buyer" means the entity to which Seller's Offer is made, or the entity purchasing Goods and/or Services from Seller. "Goods" means the products offered or sold by Seller. "Services" means Services offered or rendered by Seller. "Offer" means any quotation, bid, or proposal for Goods and/or Services made by Seller to Buyer. "Order" means Buyer's purchase order, or similar instrument. All references to "terms and conditions" herein mean and include (a) these "Terms and Conditions of Sale", (b) Seller's Special Terms and Conditions, as applicable, and (c) any other terms and conditions mutually agreed upon by the Parties in writing, in accordance with Section 3 herein. Seller and Buyer are sometimes referred to herein individually as a "Party" and collectively as the "Parties".

2. OFFERS

Unless stated otherwise in writing by Seller, all Offers made by Seller shall be valid for a period of thirty (30) days from the date of such Offer. Unless accepted by Buyer within the Offer validity period, Seller reserves the right to withdraw and/or revise its Offer. The prices offered by Seller apply only to the specific quantities, specifications, delivery schedules, and terms and conditions set forth in Seller's Offer.

3. ACCEPTANCE

The terms and conditions herein apply to all Offers made by Seller, and all Orders accepted by Seller. Acceptance of Buyer's Order, and any changes or amendments thereto, is strictly conditioned upon Buyer's assent to Seller's terms and conditions. Unless otherwise agreed upon in writing by a duly authorized representative of Seller, Seller objects to, and is not bound by, any terms or conditions that differ from, add to, or modify the terms and conditions herein. Seller's failure to object to any terms and conditions or any other provisions contained in any communication from Buyer, including, but not limited to, Buyer's Order and any changes or amendments thereto, does not waive any of the terms and conditions specified herein. Seller's acceptance of Buyer's Order or Buyer's receipt of Goods, whichever occurs first, shall conclusively evidence Buyer's unconditional acceptance of these terms and conditions. The terms and conditions herein shall be applicable whether or not they are attached to or enclosed with Goods and/or Services sold or to be sold hereunder.

4. PRICES

Unless otherwise agreed in writing by a duly authorized representative of Seller, all prices are stated in United States Dollars, and all invoices issued by Seller and payments made by Buyer shall be in United States Dollars.

5. PAYMENT TERMS

Subject to Seller approval of Buyer's credit, payment terms for domestic Orders are net thirty (30) days from date of Seller's invoice. Unless otherwise agreed in writing by a duly authorized representative of Seller, payment terms for international Orders shall be either cash in advance by wire transfer, or by an irrevocable letter of credit confirmed with Seller's bank. Buyer hereby waives any right of setoff against amounts due Buyer from Seller. All amounts due to Seller but not paid by Buyer on the due date bear interest payable at a rate equal to the lesser of (a) one and one-half percent (1.5%) of the outstanding balance per month, or (b) the maximum interest rate permitted under applicable law. Interest accrues on past due amounts as of the date on which such amounts become due until the date Seller receives payment from Buyer. Buyer shall also be liable to Seller for any expenses incidental to collection of past due amounts, including reasonable attorneys' fees and court costs.

6. TAXES

The amount of any present or future sales, use, excise, import duty, or other tax applicable to the manufacture, sale, or lease of Goods shall be added to Seller's invoice and shall be paid by Buyer, unless Buyer provides Seller a valid tax exemption certificate acceptable to the applicable taxing authority.

7. INSPECTION AND TESTS

All Goods manufactured by Seller are subject to Seller's standard inspection and quality assurance processes and, if applicable, acceptance testing at Seller's facility. Any additional requirements mutually agreed by the Parties, including, without limitation, Buyer's source inspection or additional testing, are at Buyer's sole expense. If Buyer requires inspection by Buyer at Seller's place of manufacture, such inspection shall not unreasonably interfere with Seller's operations. Seller shall give Buyer at least two (2) business days advance notice of availability of Goods for Buyer's inspection. If Buyer fails to perform such inspection within three (3) business days after said notice is received, or such other period as agreed by Seller, inspection by Buyer shall be deemed to have been waived by Buyer.

8. PACKING AND PACKAGING

All Goods shall be packed and packaged in accordance with Seller's standard commercial packing and packaging methods. Any nonstandard or special packing or packaging requested by Buyer shall be at Buyer's sole expense.

9. SHIPPING TERMS, TITLE, AND RISK OF LOSS

Unless agreed otherwise by Seller in writing, all domestic shipments shall be delivered F.O.B. Seller's shipping dock in accordance with UCC, and all shipments to locations outside the United States shall be delivered Ex Works to Buyer's designated carrier in accordance with Incoterms 2010. Risk of loss and title to Goods shall pass upon such delivery. Unless otherwise agreed in writing, title to software delivered by Seller or embedded in Seller's products, if applicable, shall remain with Seller, and use of such software by Buyer or third-parties shall be conditioned upon execution of a license agreement or confidentiality agreement between Seller and Buyer. If Seller prepays shipping, insurance, or other related charges, Buyer agrees to reimburse Seller promptly for such charges.

10. EXPORT COMPLIANCE

Shipment of Goods, provision of Services, and delivery of technical information under Buyer's Order is subject to all decrees, statutes, laws, rules, and regulations which govern export, re-export, or otherwise pertain to export controls of the United States and the country of Buyer, including, but not limited to, the U.S. Department of Commerce Export Administration Regulations (EAR) and the U.S. Department of State International Traffic in Arms Regulations (ITAR). The Parties each agree to provide to the other in a timely manner such information and assistance as may reasonably be required in connection with securing any required authorizations or licenses. Buyer agrees to indemnify and hold Seller harmless from any claims or liability arising from Buyer's failure to comply with all such decrees, statutes, laws, rules, and regulations. Any Order accepted by Seller which cannot be fulfilled due to law or regulations or Seller's inability to obtain any required export license, may be cancelled by Seller. In such case, Seller shall have no liability or obligations to Buyer.

11. DELIVERY SCHEDULES AND FORCE MAJEURE

Shipping dates are approximate, and require prompt receipt of all necessary Buyer-furnished information and materials, if applicable. Any delay or failure of Seller to perform its obligations under Buyer's Order shall be excused if such delay or failure is the result of an unforeseeable event or occurrence beyond the reasonable control of Seller, and without its fault or negligence, including, but not limited to, acts of God, actions by any governmental authority (whether valid or invalid), fires, floods, windstorms, explosions, riots, natural disasters, wars, sabotage, labor problems (including lockouts, strikes, and slowdowns), inability to obtain power, utilities, materials, labor, equipment, transportation, or court injunction.

12. CHANGES

Buyer may request changes to the general scope of Buyer's Order by a written notice to Seller, provided, however, such changes shall not be effective until and unless Seller consents to such changes in writing. If any such changes cause an increase or decrease in the cost of, or the time required for, the performance of any part of Buyer's Order, an equitable adjustment shall be made to the price and/or delivery schedule, and Buyer's Order shall be modified to reflect such change and adjustment in writing.

13. TERMINATION FOR CONVENIENCE

Buyer may request cancellation or termination of Buyer's Order for Buyer's convenience, in whole or in part, by providing prior written notice to Seller. Seller agrees to cooperate with Buyer in attempting to effect such cancellation or termination conditioned upon Buyer paying Seller for all Goods delivered and/or Services performed, and for all work in process, including all applicable direct and indirect costs, normal profit on such costs, settlements with suppliers, and related termination expenses. To the extent possible, Seller shall use reasonable commercial efforts to divert materials and work in process from Buyer's Order to other customers' orders.

14. TERMINATION FOR DEFAULT

Either Party may terminate the Order if the other Party materially breaches a material provision of the Order. In the event that a Party (the "Breaching Party") is in material breach of a material provision of the Order, the other Party (the "Non-Breaching Party") shall submit a written cure notice to the Breaching Party advising of such breach. The Breaching Party shall have thirty (30) days from receipt of such notice to cure the breach. If the Breaching Party does not cure the breach within the thirty (30) day cure period, the Non-Breaching Party may terminate the Order. Either Party may immediately terminate the Order if the other Party is adjudicated bankrupt, files a petition for bankruptcy, makes an assignment for the benefit of creditors, or if an action under any law for the relief of debtors is taken.

15. LIMITED WARRANTY

Seller warrants that Goods delivered under Buyer's Order shall be free from defects in material and workmanship, and conform to Seller's specifications for a period of six (6) months from the date of original shipment. Seller warrants all Services for ninety (90) days after completion unless otherwise mutually agreed upon under a separate Service contract. This warranty does not apply to any Goods that, upon examination by Seller, are found to have been (a) mishandled, misused, abused, or damaged by Buyer or Buyer's customer, (b) altered or repaired without Seller's prior written approval, or (c) improperly stored, installed, operated, or maintained in a manner inconsistent with Seller's instructions. This warranty does not apply to defects attributed to normal wear and tear. Seller, at its sole option, shall repair or replace defective Goods, or issue Buyer a credit for the original price of the defective Goods. In the case of defective Services, Seller shall re-perform such Services. Such repair, replacement, credit, and re-performance by Seller shall be Buyer's sole remedy for defective Goods and Services. Under no circumstances is Seller liable for retrieval, removal, dismantling, re-installation, redeployment, or re-commissioning of any defective Goods or any costs associated therewith including, but not limited to, any subsea work performed below the waterline, heavy lift operations, or the transportation to or from offshore locations. Consumables obtained from third-parties shall bear the warranty of their manufacturer. The warranty period for repaired or replaced Goods or re-performed Services shall be the unexpired portion of the original warranty period. THESE EXPRESS WARRANTIES, INCLUDING THE REMEDIES SET FORTH HEREIN, ARE EXCLUSIVE AND ARE IN LIEU OF ANY AND ALL OTHER WARRANTIES, EXPRESS OR IMPLIED. NO WARRANTY OF MERCHANTABILITY OR FITNESS FOR A PARTICULAR PURPOSE IS INTENDED OR GIVEN. IN THE CASE OF GOODS OTHER THAN THOSE OF SELLER'S OWN MANUFACTURE, SELLER MAKES NO WARRANTIES, EXPRESS, STATUTORY, OR IMPLIED.

16. RETURN AUTHORIZATIONS

Buyer's return of defective Goods to Seller is subject to Seller's then current return authorization procedures. Buyer shall promptly notify Seller of any nonconformance or defects in Goods, and provide Seller a reasonable opportunity to inspect such Goods. Goods shall not be returned without Seller's prior authorization, as evidenced by a Return Material Authorization (RMA) number issued by Seller. Once a RMA number is obtained, Buyer shall return Goods transportation and insurance prepaid in accordance with instructions issued by Seller. Failure to follow Seller's return authorization procedures may result in lost Goods, delays, additional service, restocking charges, warranty denial, or refusal of a return shipment. The RMA number must appear on the shipping label and all paperwork associated with the return. Buyer shall identify the model or part number, description, and serial number, if applicable, for each of the Goods returned along with an explanation of the nonconformance or defect. Issuance of a RMA number by Seller does not necessarily mean Seller agrees that returned Goods are defective or covered under warranty, or that Goods will be repaired or replaced at no cost to Buyer. If any Goods returned by Buyer are found to not be defective, Buyer shall be so notified and such Goods shall be repaired, replaced, or returned to Buyer at Buyer's option and expense. Such repair or replacement shall not be performed until and unless Buyer issues an Order to Seller authorizing such repair or replacement at Seller's then-current repair or replacement price. In addition, Seller may charge Buyer for any testing or inspection costs. In no event shall Seller retain or store returned Goods for more than six (6) months. Goods repaired or replaced under warranty shall be returned to Buyer at Seller's expense. New and unused standard products returned for credit shall be subject to a restocking charge equal to the great of (a) \$25.00, or fifteen percent (15%) of the original price of the product.

17. TOOLING

Unless agreed otherwise by Seller in writing, all tooling, fixtures, equipment, tools, software, and designs produced, acquired, or used by Seller for the purposes of fulfilling Buyer's Order shall remain the property of the Seller.

18. BUYER'S OBLIGATION OF ASSISTANCE (APPLICABLE TO SERVICES)

To the extent Seller is required to perform Services for Buyer, Buyer shall provide Seller all information reasonably necessary for Seller to perform Services, including any plans, plant layouts, wiring instructions, and operational information. This includes previous studies, reports, or other information relative to the design, installation, and selection of equipment. Buyer shall grant Seller access to its property and other public and private lands, as reasonably required for performance of Services, and facilitate such access. Buyer shall also provide safe storage of Seller's equipment, materials, and tools during the performance of Services at Buyer or Buyer's customer's worksite. Buyer agrees to reasonably cooperate as necessary to facilitate Seller's performance of Services. Buyer covenants that it has fully and accurately disclosed to Seller all general and local conditions that may affect Seller's performance of Services. Buyer acknowledges that Seller is entitled to rely on information furnished by Buyer in developing its specifications, equipment selection, price, and in performing Services.

19. PROPRIETARY RIGHTS

Seller shall retain all right, title, and interest in and to any data, information, software programs, tools, specifications, templates, scripts, ideas, concepts, inventions, works of authorship, products, know-how, processes, techniques, and the like used or developed by Seller, its employees, and its subcontractors in connection with Buyer's Order.

Buyer agrees that Seller retains all proprietary rights in and to all products, specifications, designs, discoveries, inventions, patents, copyrights, trademarks, trade secrets, and other proprietary rights relating to Goods or Services. Unless otherwise identified in writing to Seller, no information or knowledge heretofore or hereafter disclosed to Seller in the performance of, or in connection with, the terms hereof, shall be deemed to be confidential or proprietary and any such information or knowledge shall be free from restrictions, other than a claim for patent infringement, as part of the consideration hereof.

20. PATENT, COPYRIGHT, AND TRADEMARK INDEMNIFICATION

Seller shall hold harmless and indemnify Buyer against all third-party claims, judgments, costs, and fees, including attorney fees, relating to infringement of any United States, Canada, Brazil, Japan, Italy, France, United Kingdom, or Norway patent, copyright, trademark, or design to the extent that (a) the infringing Goods are manufactured, sold, or used, in whole or in part, pursuant to Seller's specifications, designs, drawings, or other technical data, and (b) provided that Buyer notifies Seller in writing of any such claim as soon as reasonably practicable, and allows Seller to control, and reasonably cooperates with Seller in the defense of any such claim and related settlement negotiations. To the extent that any Goods are held by a court of competent jurisdiction or are believed by Seller to infringe or otherwise violate a third-party's proprietary rights, Seller may, at its option and expense, either (a) modify the affected Goods to be non-infringing, or (b) obtain for Buyer a license to continue using such Goods on substantially the same terms set forth herein, or, if neither of the foregoing alternatives is reasonably available to Seller, (c) Seller may require Buyer to return the infringing Goods and all rights thereto, and refund to Buyer the price paid to Seller by Buyer for the infringing Goods. Seller shall have no obligation under this provision to the extent any claim is based on (a) modifications of Goods or deliverables by a party other than Seller or Seller's authorized representative, (b) the combination, operation, or use of Goods with equipment, devices, software, or data not supplied by Seller, (c) the use or installation of Goods in an environment for which Goods were not intended, (d) Buyer's failure to use updated or modified versions of Goods provided by Seller, or (e) the negligent acts or omissions or willful misconduct of Buyer, its employees, representatives, or affiliates. This Section, and the indemnification provided herein, does not apply to any Goods manufactured, sold, or used, in whole or in part, pursuant to Buyer's specifications, designs, drawings, or other technical data. THE FOREGOING CONSTITUTES THE ENTIRE LIABILITY OF SELLER AND BUYER'S SOLE AND EXCLUSIVE REMEDY WITH RESPECT TO ANY CLAIMS OF INFRINGEMENT OF ANY THIRD-PARTY INTELLECTUAL PROPERTY RIGHTS.

21. CONFIDENTIALITY

Each Party (the "Receiving Party") shall keep confidential and not directly or indirectly disclose to any third party any Confidential Information, as defined herein, furnished to it by the other Party (the "Disclosing Party") in connection with Seller's Offer and/or Buyer's Order without the Disclosing Party's prior written consent. "Confidential Information" includes, but is not limited to, business, financial, statistical, and commercial information, pricing, technical data and information, formulae, analyses, trade secrets, ideas, methods, processes, know how, computer programs, designs, data sheets, schematics, configurations, and drawings. Confidential Information does not include information that (a) is or becomes generally available to the public other than as a result of disclosure by Receiving Party, (b) was available on a non-confidential basis prior to its disclosure by Disclosing Party, (c) is or becomes available to Receiving Party on a non-confidential basis from a source other than Disclosing Party when such source is not, to the best of Receiving Party's knowledge, subject to a confidentiality obligation with Disclosing Party, or (d) was independently developed by Receiving Party without reference to the Confidential Information, and Receiving Party can verify development of such information by written documentation.

22. INDEMNIFICATION

Each Party (the "Indemnifying Party") agrees to indemnify, defend, and hold harmless the other Party, its officers, directors, and employees (the "Indemnified Parties") from and against any and all liabilities, losses, expenses, liens, claims, demands, and causes of action ("Claims") for death, personal injury, or property damage arising out of any negligent act or omission of the Indemnifying Parties in the performance of Buyer's Order, except to the extent such Losses are contributed to by (a) the negligence or willful misconduct of the Indemnified Party, (b) the negligence or willful misconduct of any third parties, or (c) equipment, information, or materials furnished by Buyer to Seller. Seller's indemnification of Buyer does not apply unless Buyer (a) notifies Seller in writing of any such Claim as soon as reasonably practicable, and (b) allows Seller to control, and reasonably cooperates with Seller, in the defense of any such Claim and related settlement negotiations.

23. LIMITATION OF LIABILITY

Notwithstanding any other provision herein, under no circumstances shall either Party be liable for any consequential, special, incidental, indirect, multiple, administrative, or punitive damages, or any damage of an indirect or consequential nature arising out of or related to its performance under Buyer's Order, including, without limitation, loss of use, loss of revenues, loss of anticipated profits, and cost of capital, whether based upon breach of Buyer's Order, warranty, negligence, or any other type of Claim, and whether grounded in tort, contract, civil law, or other theories of liability, including strict liability, even if advised in advance of the possibility of such damages. Seller's total liability arising from or related to Buyer's Order, including, but not limited to, its liability for indemnity, defense, and hold harmless obligations under Buyer's Order, is limited to no more than the amount paid by Buyer to Seller under Buyer's Order, and Buyer agrees to indemnify Seller for any excess amounts. To the extent that this limitation of liability conflicts with any other Section or provision herein, such provision shall be regarded as amended to whatever extent required to make such provision consistent with this clause.

24. ETHICS AND VALUES

Seller is committed to uncompromising ethical standards, strict adherence to laws and regulations, and customer satisfaction. Buyer is encouraged to communicate any concerns or questions regarding the ethics and values of Seller to the Teledyne Corporate Ethics Help Line at 1-877-666-6968.

25. ORDER OF PRECEDENCE

The following order of precedence shall apply in the event of an inconsistency within Buyer's Order and its related documents, as applicable:

- (a) Seller's Special Terms and Conditions
- (b) Seller's Terms and Conditions of Sale
- (c) Specification
- (d) Statement of Work or Scope of Services

26. GOVERNING LAW AND VENUE

The performance of the Parties, and any judicial or arbitration proceedings, shall be construed and governed in accordance with the laws of the State of California, United States of America, excepting its laws and rules relating to conflict of law. Neither (a) the United Nations Convention on Contracts for the International Sale of Goods, (b) the 1974 Convention on the Limitation Period in Contracts for the International Sale of Goods (hereinafter referred to as the "1974 Convention"), nor (c) the Protocol Amending the 1974 Convention held at Vienna, Austria, on April 11, 1980, apply in any manner to the interpretation or enforcement of Seller's Offer, or Buyer's Order.

27. DISPUTES AND ARBITRATION

The Parties shall attempt to resolve any dispute, controversy, or claim arising under or relating to Seller's Offer or Buyer's Order, or to a material breach, including its interpretation, performance, or termination. If the Parties are unable to resolve such dispute, either Party may refer the dispute to arbitration. The arbitration shall be conducted in English and in accordance with the Commercial Rules of the American Arbitration Association, which shall administer the arbitration and act as appointing authority. The

Page G

arbitration, including the rendering of the decision and/or award, shall take place in San Diego, California, United States of America, and shall be the exclusive forum for resolving the dispute, controversy, or claim. The arbitrator shall make the final determination as to any discovery disputes between the Parties. Examination of witnesses by the Parties and by the arbitrator shall be permitted. A written transcript of the hearing shall be made and furnished to the Parties. The cost of this transcript shall be borne equally by the Parties. The award or decision of the arbitrator shall state the reasons upon which the award or decision is based, and shall be final and binding upon the Parties. The prevailing Party shall be entitled to compensation for the expense of the arbitration, including, but not limited to, the award of attorneys' fees, at the discretion of the arbitrator. Both Parties waive their right to any appeal under any system of law. The award shall be enforceable before any court of competent jurisdiction upon the application to such court by either Party. The arbitrator shall have no authority to award any of the types of damages excluded by hereunder, and shall be so instructed by the Parties.

28. RELATIONSHIP OF THE PARTIES

Each Party is an independent contractor. Neither Party shall have authority to bind the other except to the extent authorized herein. This Agreement is not intended by the Parties to constitute or create a joint venture, pooling arrangement, partnership, or formal business organization of any kind. The Parties shall act as independent contractors at all times, and neither Party shall act as the agent for the other, and the employees of one shall not be deemed to be employees of the other

29. MODIFICATIONS TO ORDER

Buyer's Order may only be modified by written instrument signed by duly authorized representatives of the Parties.

30. NOTICES

All notices given by the Parties shall be made in writing, and delivered personally or sent by prepaid mail (by air-mail if the notice is being communicated internationally), or by facsimile, cable, or email addressed to the intended recipient at its address or at its electronic address. Regardless of the method of transmittal, the sending Party is responsible for obtaining a return receipt for the notice, demand, or communication.

31. ASSIGNMENT

Neither Party may assign, delegate, sublicense, or transfer, whether by operation of law or otherwise, their obligations or rights hereunder without the other Party's written consent and any assignment, delegation, sublicense, or transfer (a) without such written consent is void and of no effect and, (b) if consent is given, shall be binding upon, and inure to the benefit of the successors and assigns of the Parties. Notwithstanding any provision of these terms and conditions, Seller may, without consent, subcontract work to be performed under Buyer's Order or assign Buyer's Order to a parent, subsidiary, or affiliate company of Seller. In addition, without securing such prior consent, Seller shall have the right to assign Buyer's Order to any successor, by way of merger or consolidation, or the acquisition of substantially all of the entire business and assets of Seller relating to the subject matter of Buyer's Order, provided that such successor shall expressly assume all of the assignor's obligations and liabilities under Buyer's Order, and provided further that Seller shall remain liable and responsible to the Buyer for the performance and observance of all such obligations.

32. WAIVER; REMEDIES; COSTS

None of the Sections, terms, conditions, or provisions herein shall be waived by any act or knowledge on the part of Seller, except by written instrument signed by a duly authorized representative of Seller. The waiver by Seller of any term, condition, provision, or right hereunder or the failure to enforce at any time any of the terms and conditions herein, or any rights with respect thereto, is not a continuing waiver or a waiver of any other rights, or of any material breach or failure of performance of Buyer. The remedies herein reserved or created for Seller shall be cumulative, and additional to any other or further remedies provided at law or in equity. Seller may remedy any breach of the terms or conditions hereof without waiving the breach remedied, or without waiving any other prior or subsequent breach. Buyer shall pay all Seller's costs and expenses, including attorney's fees, incurred by Seller in exercising any of its rights or remedies hereunder or enforcing any of the terms or conditions hereof.

33. SEVERABILITY

If any term, condition, or provision herein is invalid, ineffective, or unenforceable under present or future laws, then the remainder of the terms, conditions, and provisions shall remain in full force and effect, and shall in no way be affected, impaired, or invalidated.

34. PARTIES

The Parties to any Offer, Order, or associated transaction are Seller and Buyer as identified above and unless expressly stated otherwise, no other persons, parties, or entities have any rights, or receive any benefits hereunder. Seller is an independently functioning subsidiary or business unit of Teledyne Technologies Incorporated. Neither Teledyne Technologies Incorporated, nor any of its subsidiaries, affiliates, or business units, other than Seller, have any obligations or duties hereunder and are unrelated third parties for all purposes.

35. HEADINGS

The headings used herein are for reference purposes only and shall not affect the meaning or interpretation of any term, condition, or provision herein.

36. ENTIRE AGREEMENT

These terms and conditions (including Seller's Special Terms and Conditions, as applicable) and Buyer's Order (as accepted by Seller in accordance with the terms herein), including any applicable specifications, statement of work, or other applicable documents constitute the entire agreement between the Parties and supersede any prior oral or written agreements, commitments, understandings, or communications with respect to the subject matter of Buyer's Order.

37. SURVIVAL

Notwithstanding anything else contained herein to the contrary, the Parties agree that the provisions of the following Sections shall survive the expiration or termination of Buyer's Order: Sections 5. Payment Terms; 6. Taxes; 10. Export Compliance; 13. Termination for Convenience; 14. Termination for Default; 15. Limited Warranty; 16. Return Authorizations; 19. Proprietary Rights; 20. Patent, Copyright, and Trademark Infringement; 21. Confidentiality; 22. Indemnification; 23. Limitation of Liability; 26. Governing Law and Venue; 27. Disputes and Arbitration; 28. Relationship of the Parties; 30. Notices; and 34. Parties.

- End of Document -

***Please Note: Teledyne Impulse Terms and Conditions of Sale are subject to change. Please refer to our web site for the most current document.**

www.teledyneimpulse.com/terms_and_conditions.aspx

BREAKOUTS

DESCRIPTION AND MATERIAL

- Molded neoprene or polyurethane.
- Cable jacket and conductor insulation determines overmold material.
- Number of conductors and cable diameter determines size of mold.
- Custom molds to customer specifications available upon request, contact factory for details.
- Up to 10,000psi.

USES

- Splicing cable.
- Breakout to several cables.
- Connect multiple devices to one main line.
- Economic pressure proof junction box.

GUIDELINES

- Elastomers can be seriously degraded if exposed to direct sunlight or high ozone levels for extended periods of time.

BREAKOUTS

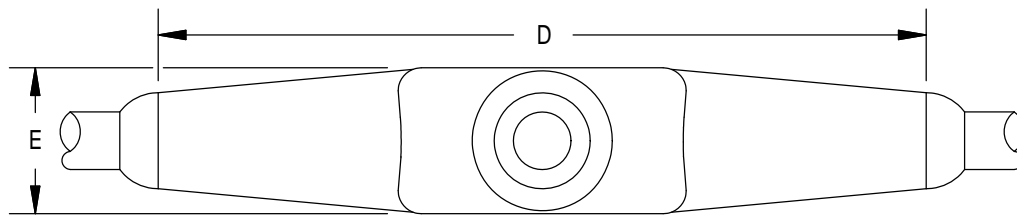
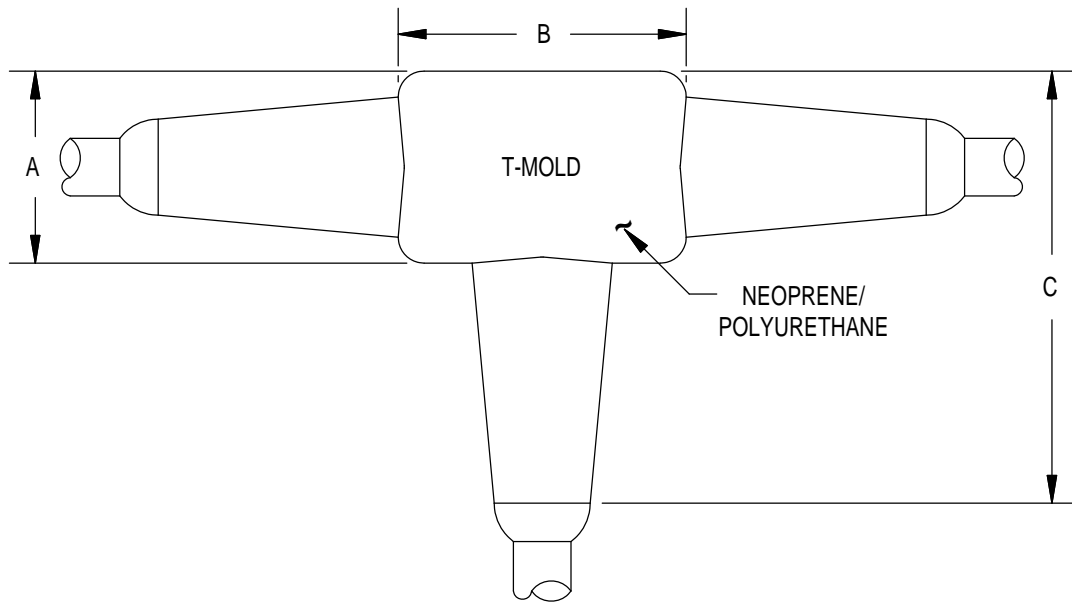

T-MOLDS					
SIZE	A	B	C	D	E
T-15	1.00	1.50	2.25	4.00	.75
T-20	1.50	2.00	3.25	5.45	1.36

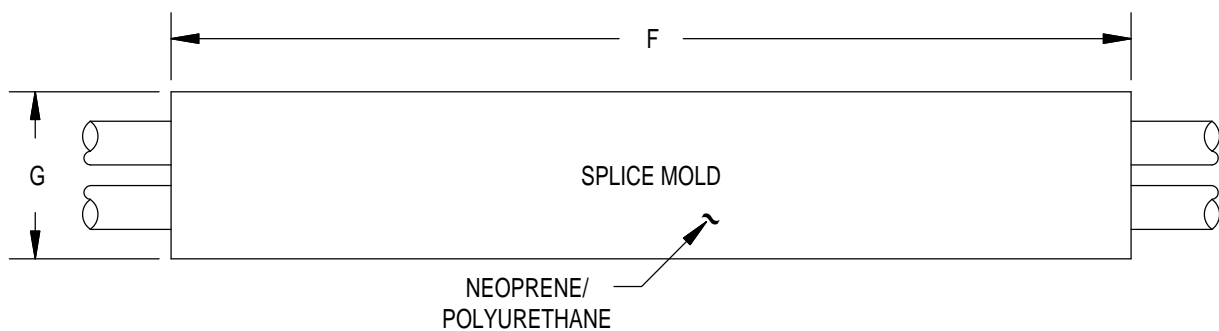

SPLICE MOLDS		
SIZE	F	G
SP-20	2.00	∅.87
SP-30	3.00	∅1.50
SP-40	4.00	∅.87
SP-46	4.60	∅1.14

SPLICE MOLDS		
SIZE	F	G
SP-50	5.00	∅.87
SP-50L	5.00	∅1.40
SP-60	6.00	∅2.00

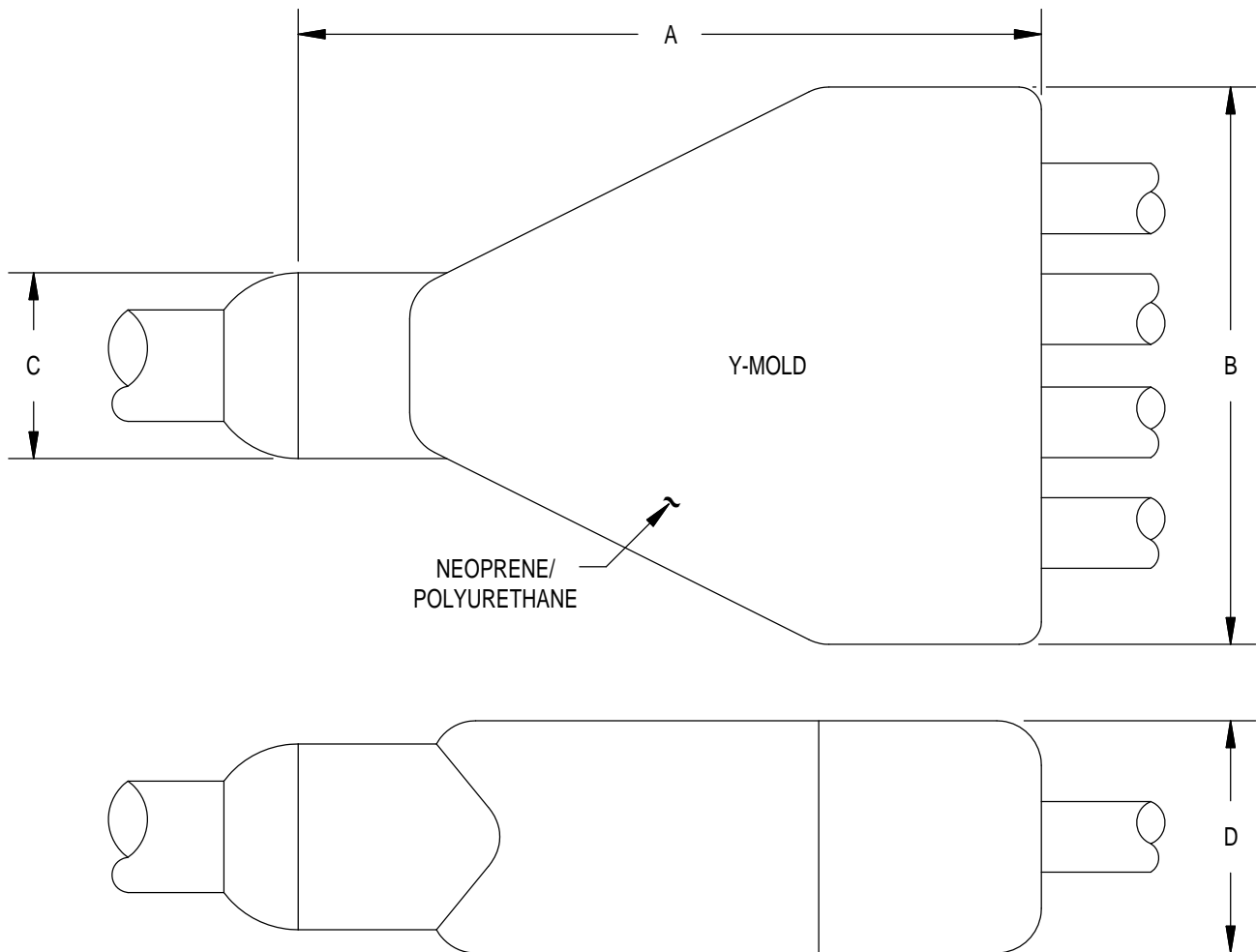

Y-MOLDS				
SIZE	A	B	C	D
Y-20	3.00	2.00	.75	.75
Y-30	4.00	2.80	1.00	1.25
Y-35	4.34	3.50	1.00	1.50
Y-45	5.50	4.40	1.25	1.75
Y-60	6.60	6.00	1.50	2.00

THIS PAGE INTENTIONALLY LEFT BLANK

-
- DESCRIPTION AND MATERIAL**
- Molded neoprene or polyurethane (for G-size) inline connectors and glass reinforced epoxy bulkhead connectors.
 - One to twelve contacts.
 - Up to 600 VDC (For higher voltages, contact factory).
 - Up to 10,000 PSI in mated condition.
 - Bulkhead connector design open face pressure rated to 5000 psi.
 - Contacts gold plated per MIL-G-45204.
 - Field installable connectors with locking sleeve available.
 - Field installable connectors have a removable tapered boot for easy access to solder pots during field installation.
- CABLE**
- Connector's amperage and voltage may be limited by amperage and voltage rating of cable to which connector is molded.
 - Inline connectors in this series, except field installables, are provided on a standard 24" length of 18 AWG SO cable unless otherwise specified. (Note: RMA provided on 24" length of 20 AWG)
- USES**
- Light to medium duty applications.
 - Hazardous environment.
 - Power transmission.
 - Signal telemetry.
 - FIB - Field installable applications.
- GUIDELINES**
- All mounting surfaces require a 32 finish.
 - Accomplish mating with minimum twisting and flexing.
 - Align indexes.
 - Care must be taken not to damage or bend pins in unplugged conditions.
 - FS can trap water (suggest flush with alcohol and blow dry).
 - Lubricate MP mating side with 3M Silicone Lubricant or Dow Corning #111 Valve Lubricant or equivalent.
 - Lubricate o-rings with Dow Corning #111 Valve Lubricant or equivalent.
 - Avoid o-ring cuts and nicks.
 - Replace o-rings when re-using connectors.
 - Avoid contact with noxious solvents.
 - Elastomers can be seriously degraded if exposed to direct sunlight or high ozone levels for extended periods of time.

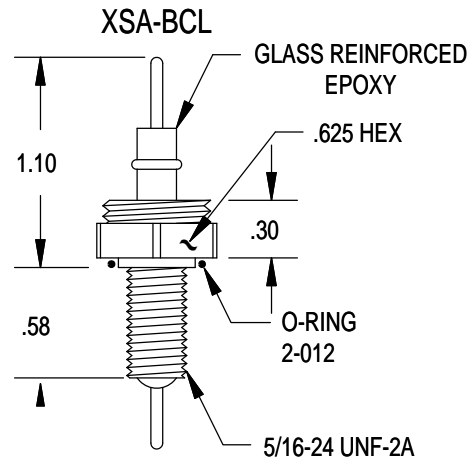
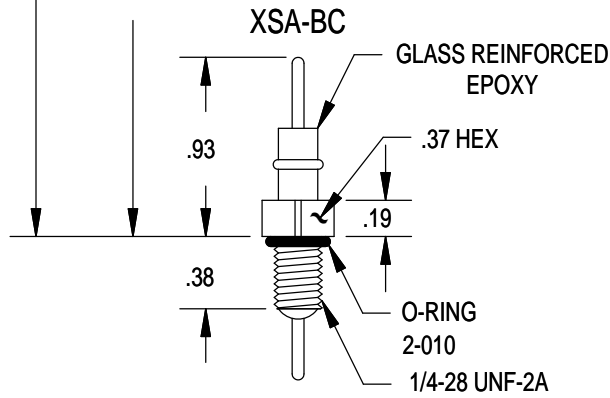
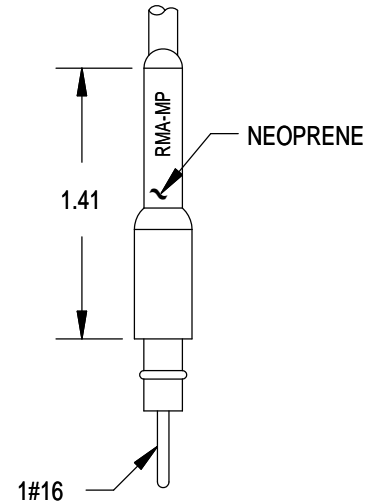
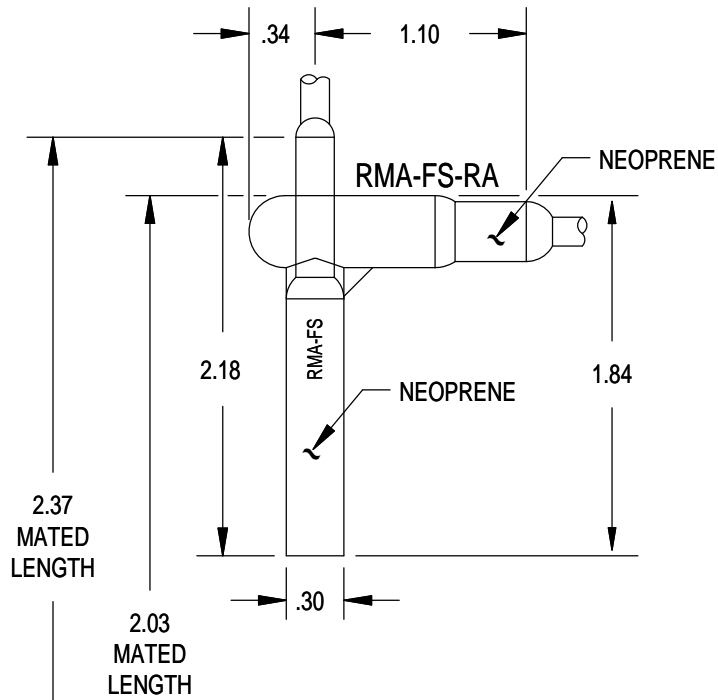

MOUNTING INSTRUCTIONS XSA-BC

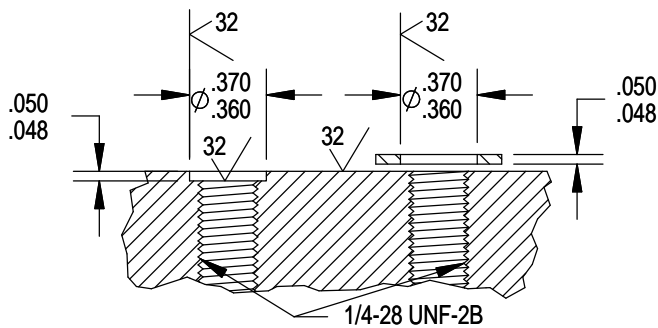

MOUNTING INSTRUCTIONS XSA-BCL

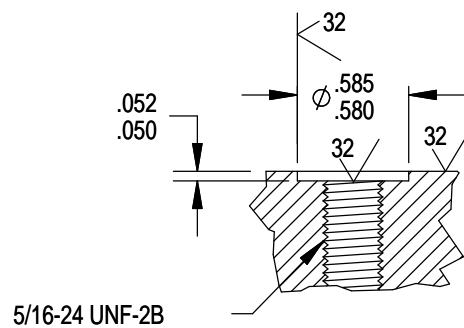

RMA-FS W/LOCKING SLEEVE

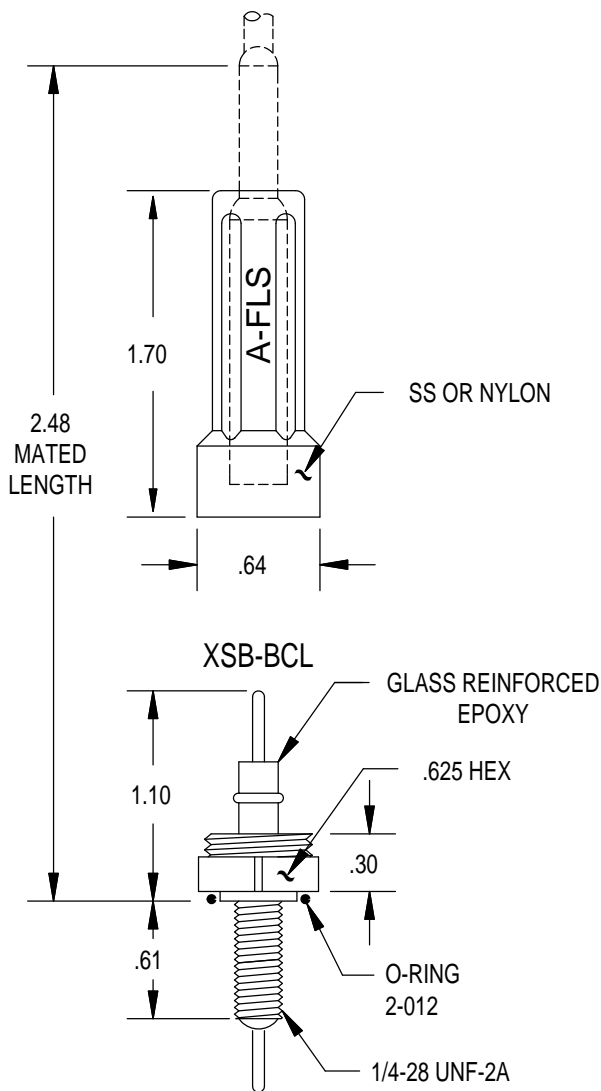

SLIP ON SERIES

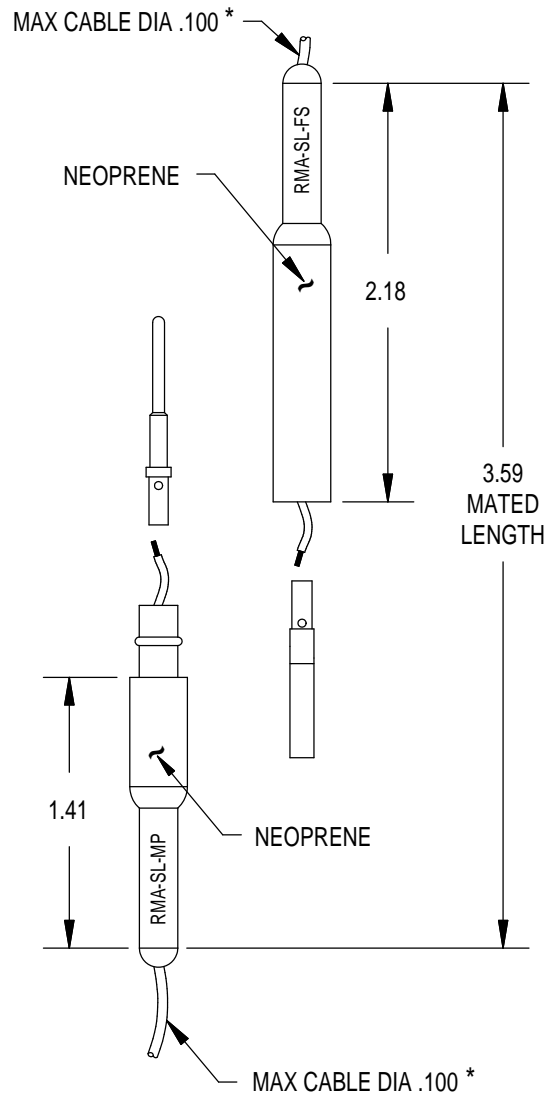

MOUNTING TORQUE FOR XSA-BC, XSB-BCL	not to exceed 6 in lbs	MOUNTING TORQUE FOR XSA-BCL	not to exceed 8 in lbs
		MATED PRESSURE RATING (psi)	10,000
DUMMY PLUG FOR XSA-BC/BCL, XSB-BCL, RMA-MP		DUMMY PLUG FOR RMA-FS	
RMA-FSD LP		LOW PRESSURE < 4,000 psi	RMA-MPD-LP
		HIGH PRESSURE > 4,000 psi	RMA-MPD-HP
NOTE: Locking sleeves available in plastic or stainless steel, see Technical Bulletin 20 40. * Must specify conductor diameter when ordering slip on series.			

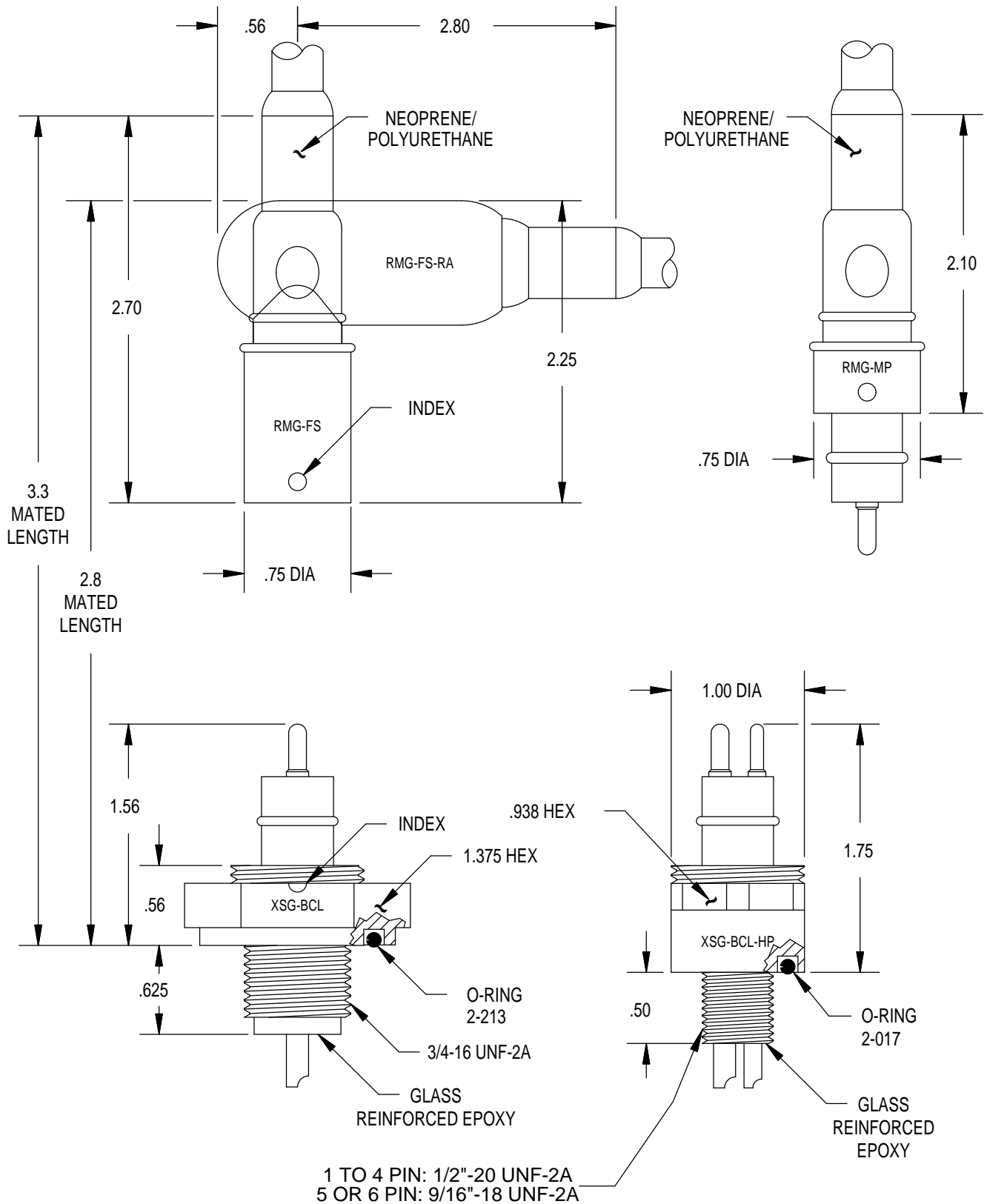

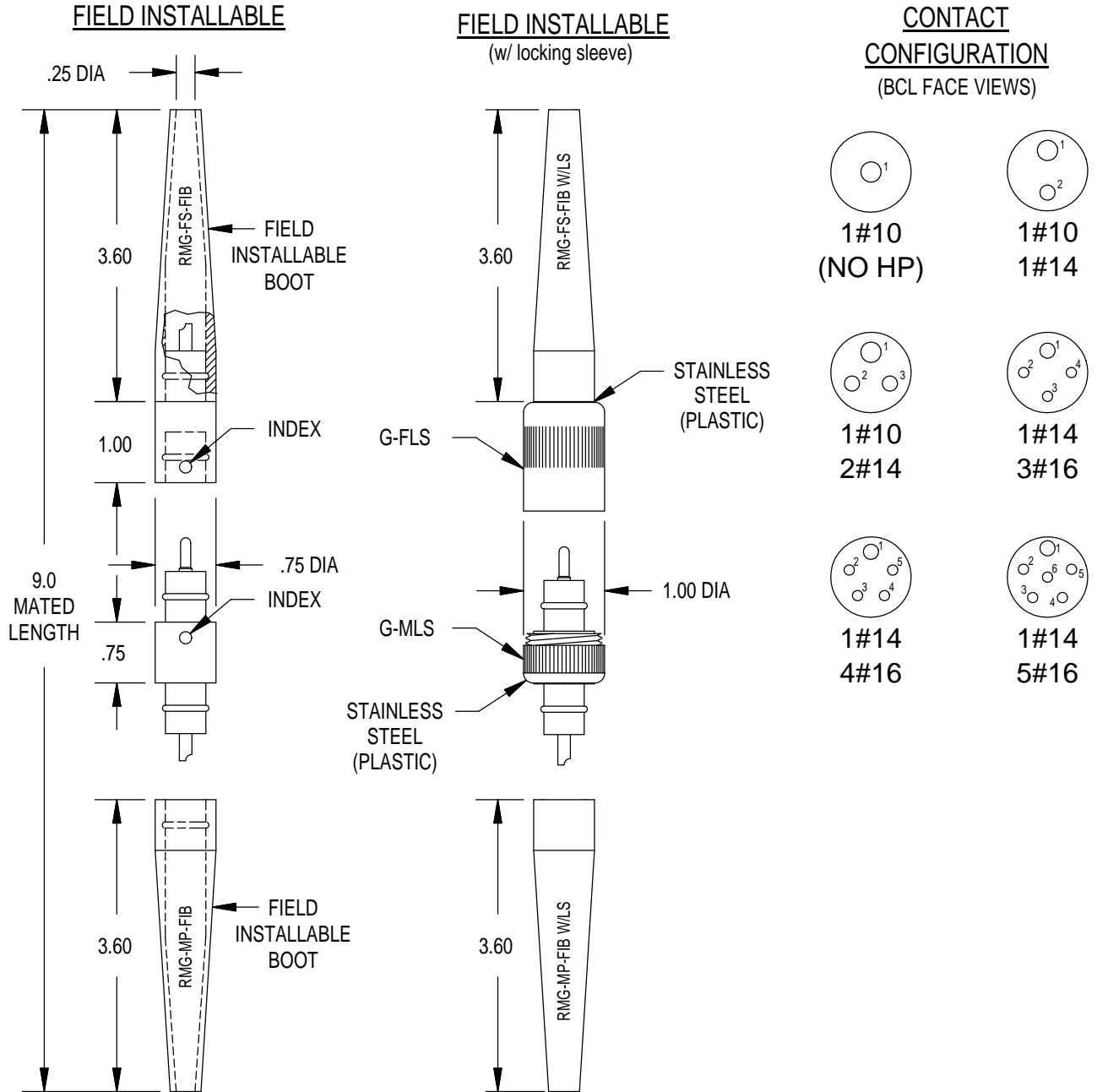

MOUNTING TORQUE FOR XSG-BCL	not to exceed 70 in lbs	MATED PRESSURE RATING (psi) FOR XSG-BCL	10,000
MOUNTING TORQUE FOR XSG-BCL-HP	not to exceed 18 in lbs	MATED PRESSURE RATING (psi) FOR XSG-BCL-HP	10,000
DUMMY PLUG FOR XSG-BCL, RMG-MP		DUMMY PLUG FOR RMG-FS	
RMG-*-FSD		LOW PRESSURE < 4,000 psi	RMG-MPD-LP
		HIGH PRESSURE > 4,000 psi	RMG-*-MPD-HP
NOTE: Locking sleeves available in plastic or stainless steel, see Technical Bulletin 20 40. * Please specify number of contacts.			

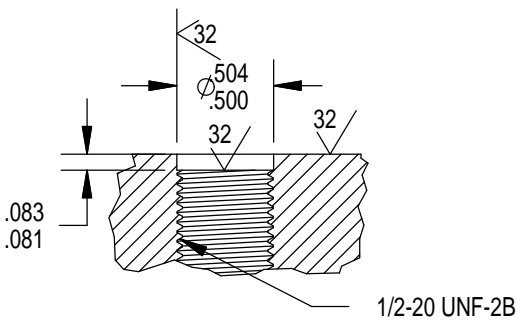
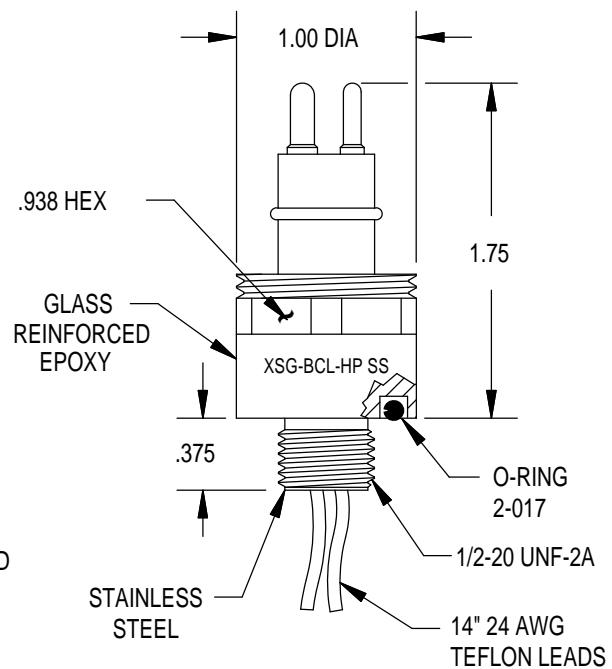
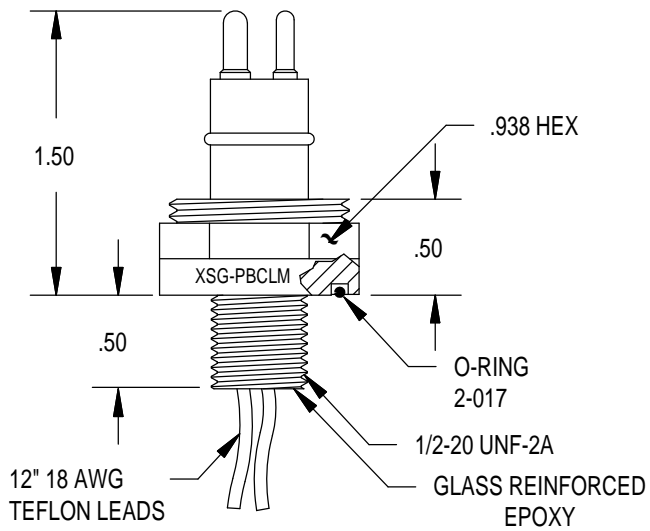
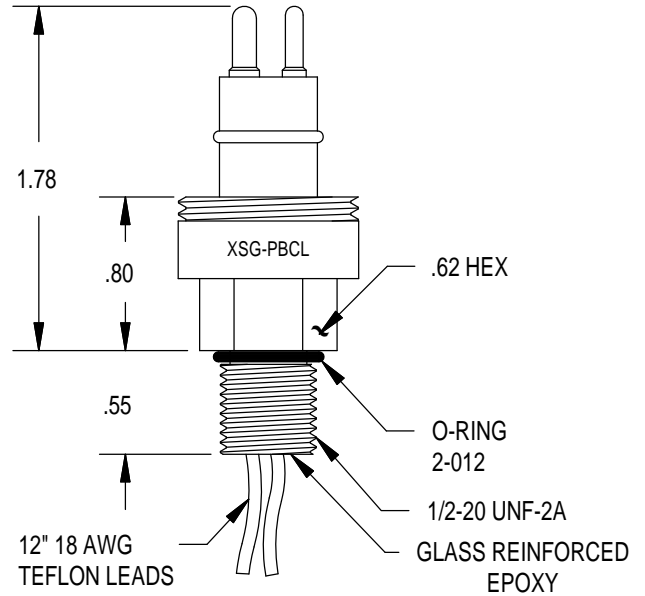
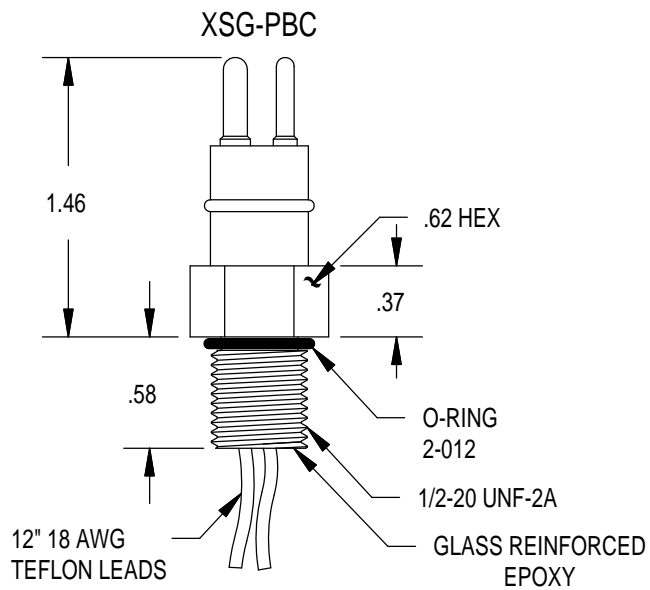

CONTACT CONFIGURATION
(BCL FACE VIEWS)

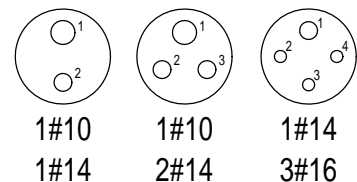

MOUNTING INSTRUCTIONS

MOUNTING TORQUE FOR XSG-PBC/PBCL/PBCLM	not to exceed 15 in lbs	MATED PRESSURE RATING (psi) FOR XSG-PBC/PBCL/PBCLM	10,000
NOTE: See Technical Bulletin 20 21 for dummy specifications.			

AG206/AG306

GLASS REINFORCED EPOXY /
RUBBER / POLYURETHANE MOLDED SERIES

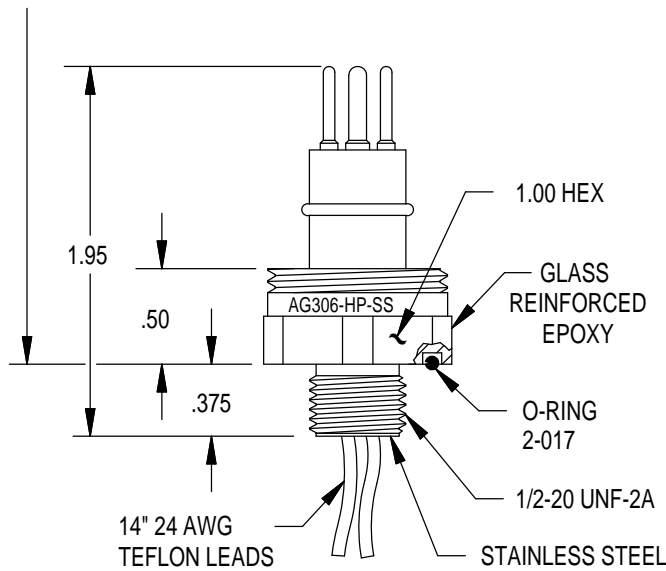
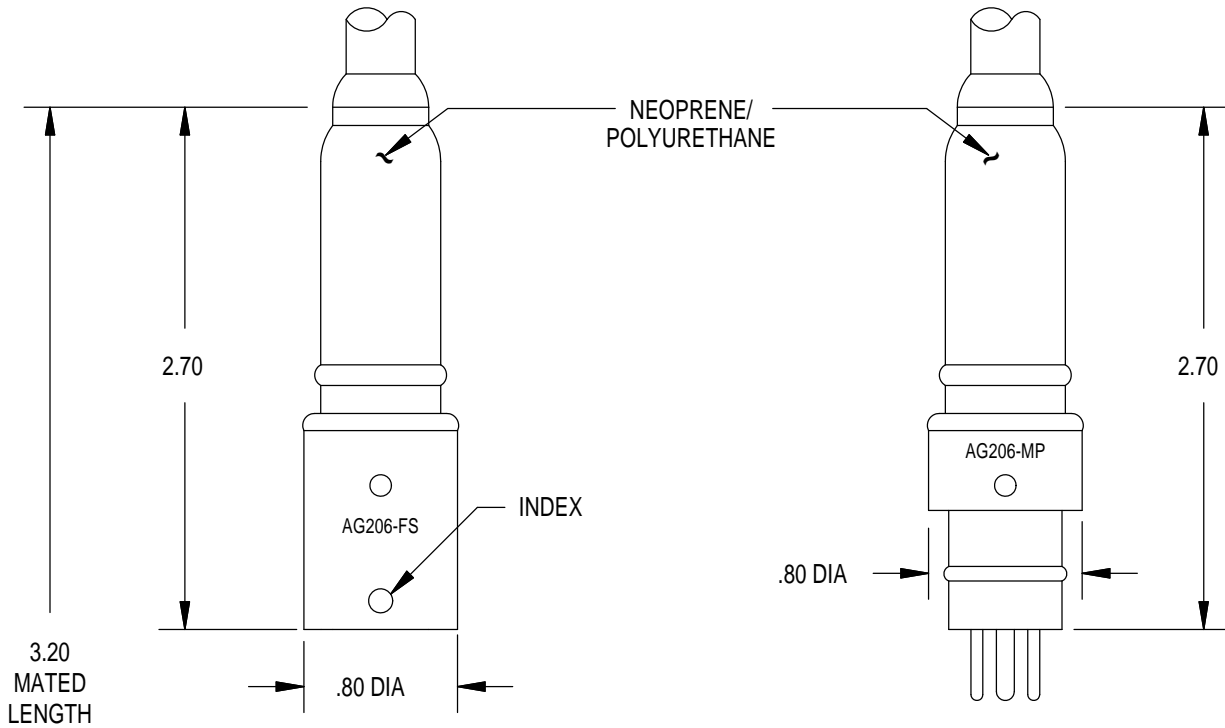

**CONTACT
CONFIGURATION
AG-206/306 ONLY
(FACE VIEW-BCL)**

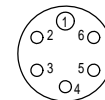

**1#14
5#16**

MOUNTING TORQUE FOR AG-306	not to exceed 15 in lbs	MATED PRESSURE RATING (PSI)	10,000
DUMMY PLUG FOR AG-306		DUMMY PLUG FOR AG-206-FS	
AG-206-FSD		LOW PRESSURE < 4,000 psi	AG-206-MPD-LP
		HIGH PRESSURE > 4,000 psi	AG-206-MPD-HP
NOTE: Locking sleeves available in plastic or stainless steel, see Tech. Bulletin 20 40.			

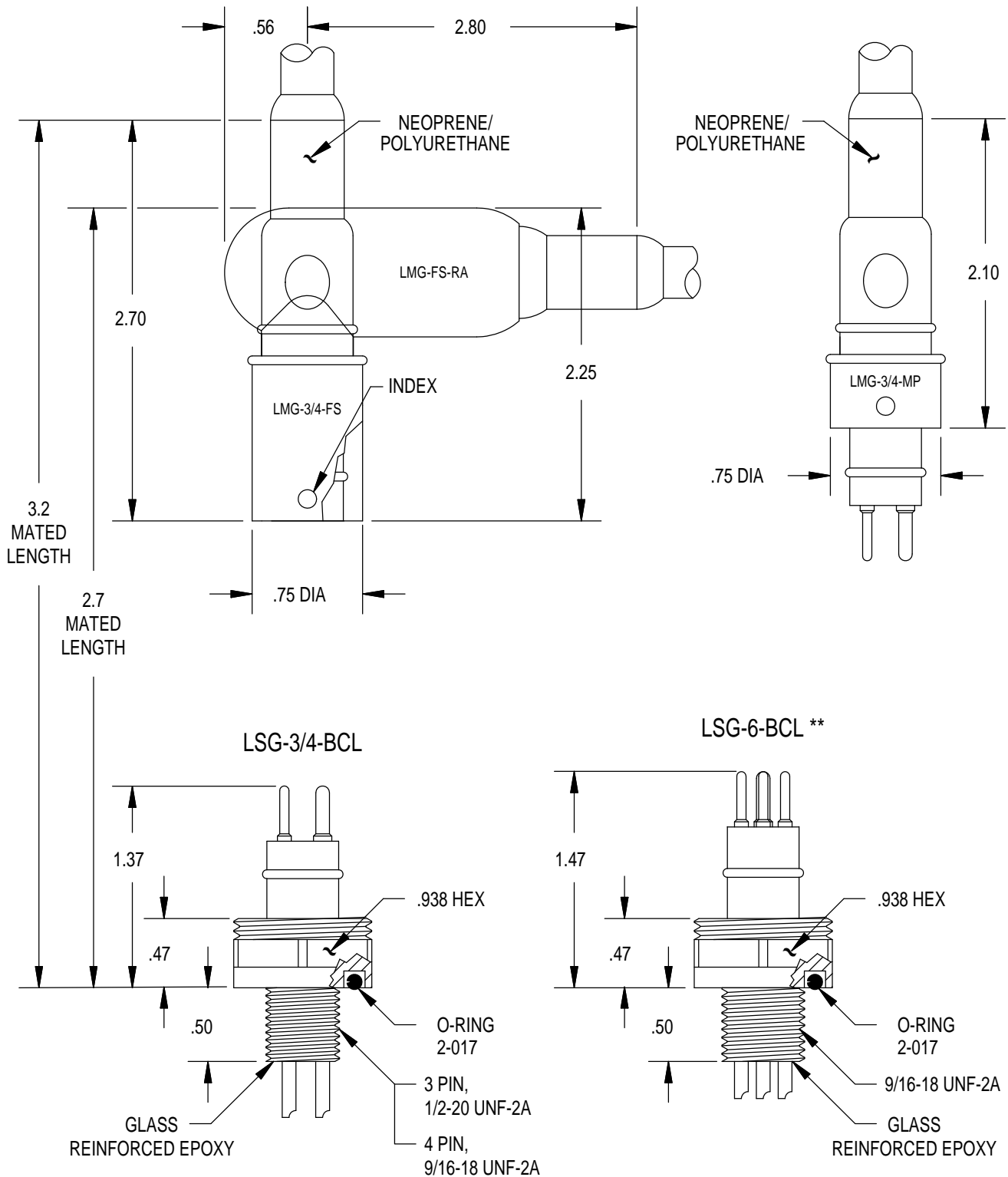

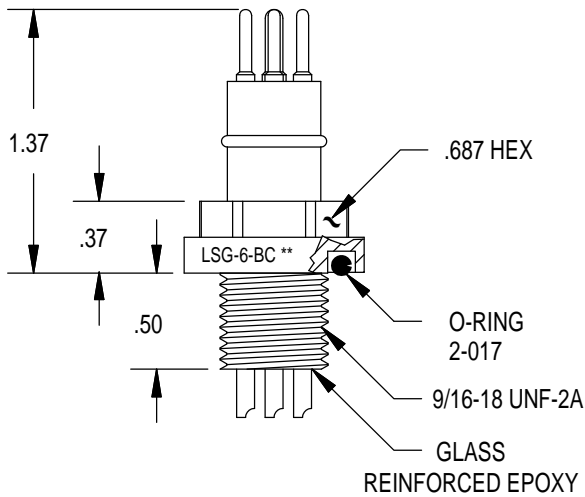
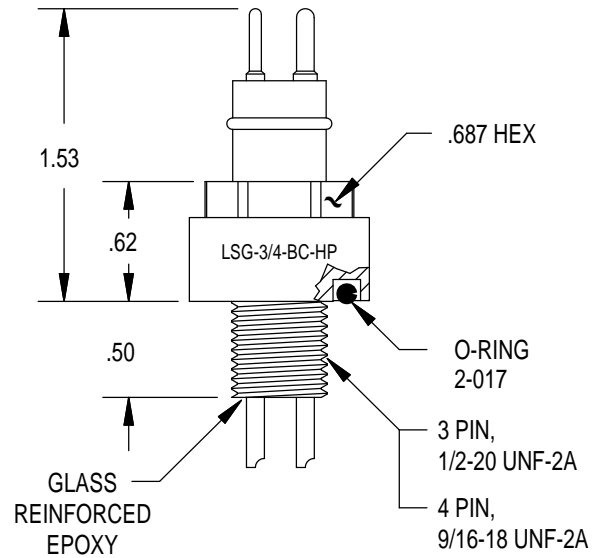
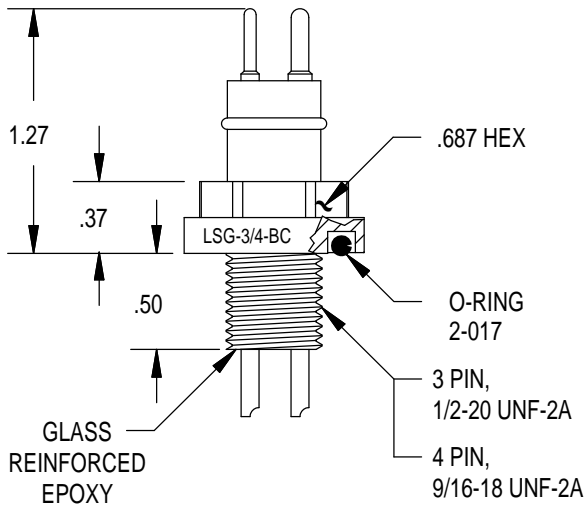

**CONTACT
CONFIGURATION
(BCL FACE VIEWS)**

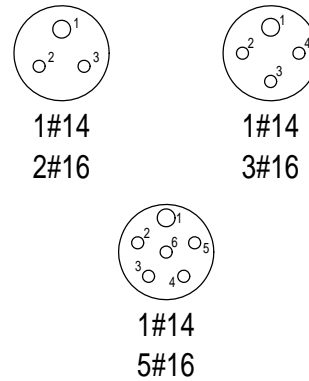

MOUNTING TORQUE FOR LSG-BCL/BC	not to exceed 18 in lbs	MATED PRESSURE RATING (psi) FOR LSG-BCL/BC	3,000
MOUNTING TORQUE FOR LSG-BC-HP	not to exceed 18 in lbs	MATED PRESSURE RATING (psi) FOR LSG-BC-HP	10,000
DUMMY PLUG FOR LSG-BCL/BC/BC-HP, LMG-MP		DUMMY PLUG FOR LMG-FS	
LMG-*-FSD	LOW PRESSURE < 4,000 psi		LMG-*-MPD-LP
	HIGH PRESSURE > 4,000 psi		LMG-*-MPD-HP
NOTE: Locking sleeves available in plastic or stainless steel, see Technical Bulletin 20 40. * Please specify number of contacts (3 or 4).			
** LSG-6 CONNECTORS MATE TO RMG-6-FS. See Technical Bulletin 20 20.			

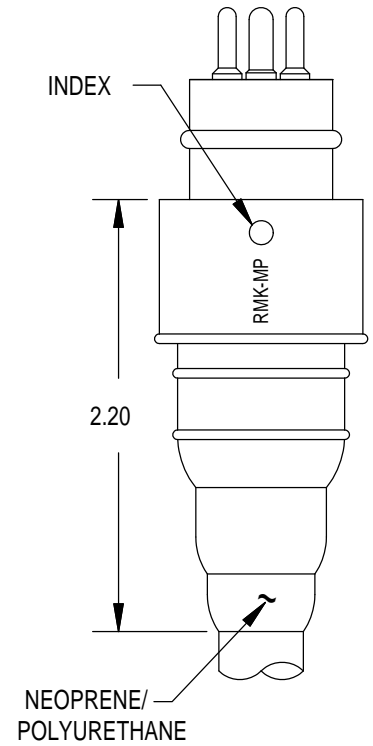
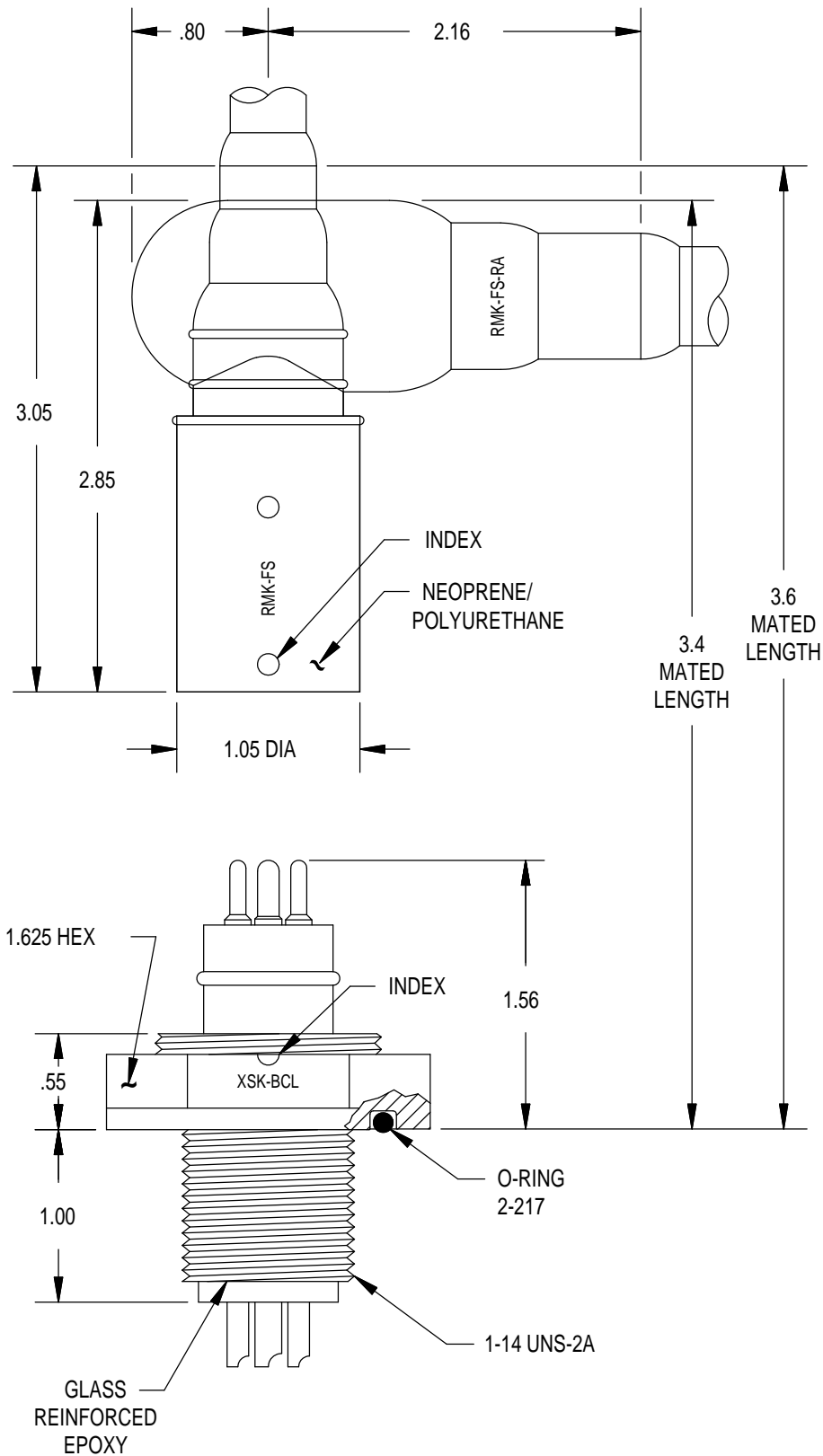

FIELD INSTALLABLE

CONTACT CONFIGURATION
(BCL FACE VIEWS)

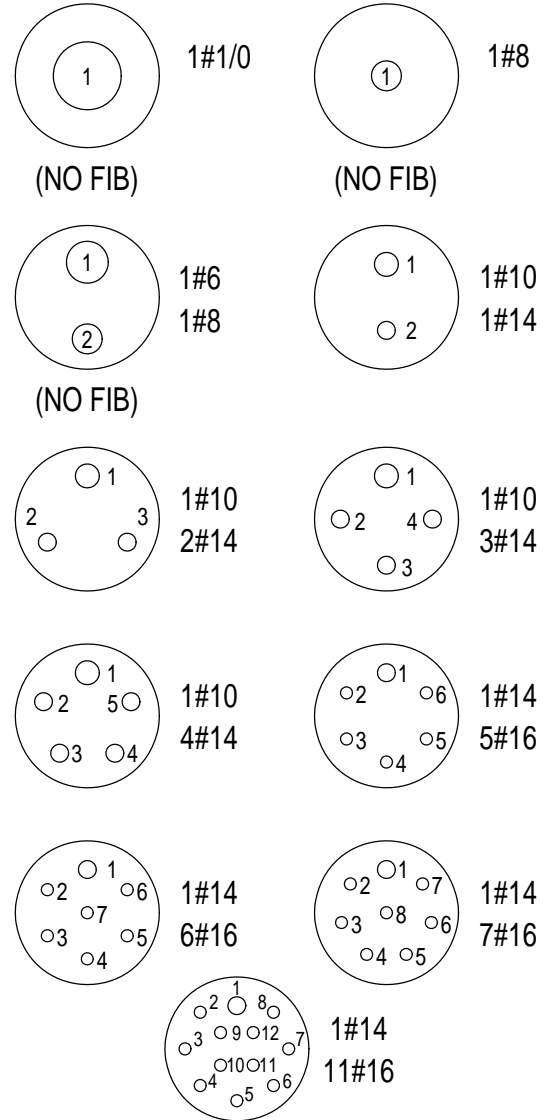
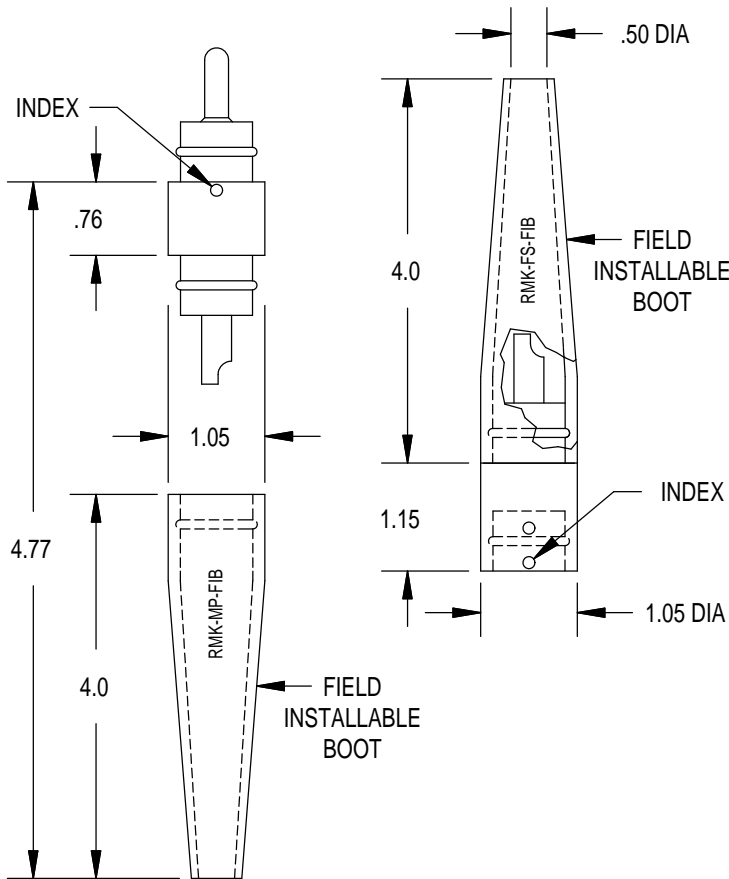

MOUNTING TORQUE FOR XSK-BCL	not to exceed 130 in lbs	MATED PRESSURE RATING (psi) FOR XSK-BCL	10,000
DUMMY PLUG FOR XSK-BCL, RMK-MP		DUMMY PLUG FOR RMK-FS	
RMK*-FSD	LOW PRESSURE < 4,000 psi	RMK-MPD-LP	
	HIGH PRESSURE > 4,000 psi	RMK*-MPD-HP	
NOTE: Locking sleeves available in plastic or stainless steel, see Technical Bulletin 20 40. * Please specify number of contacts.			

LOCKING SLEEVES

PLASTIC LOCKING SLEEVES

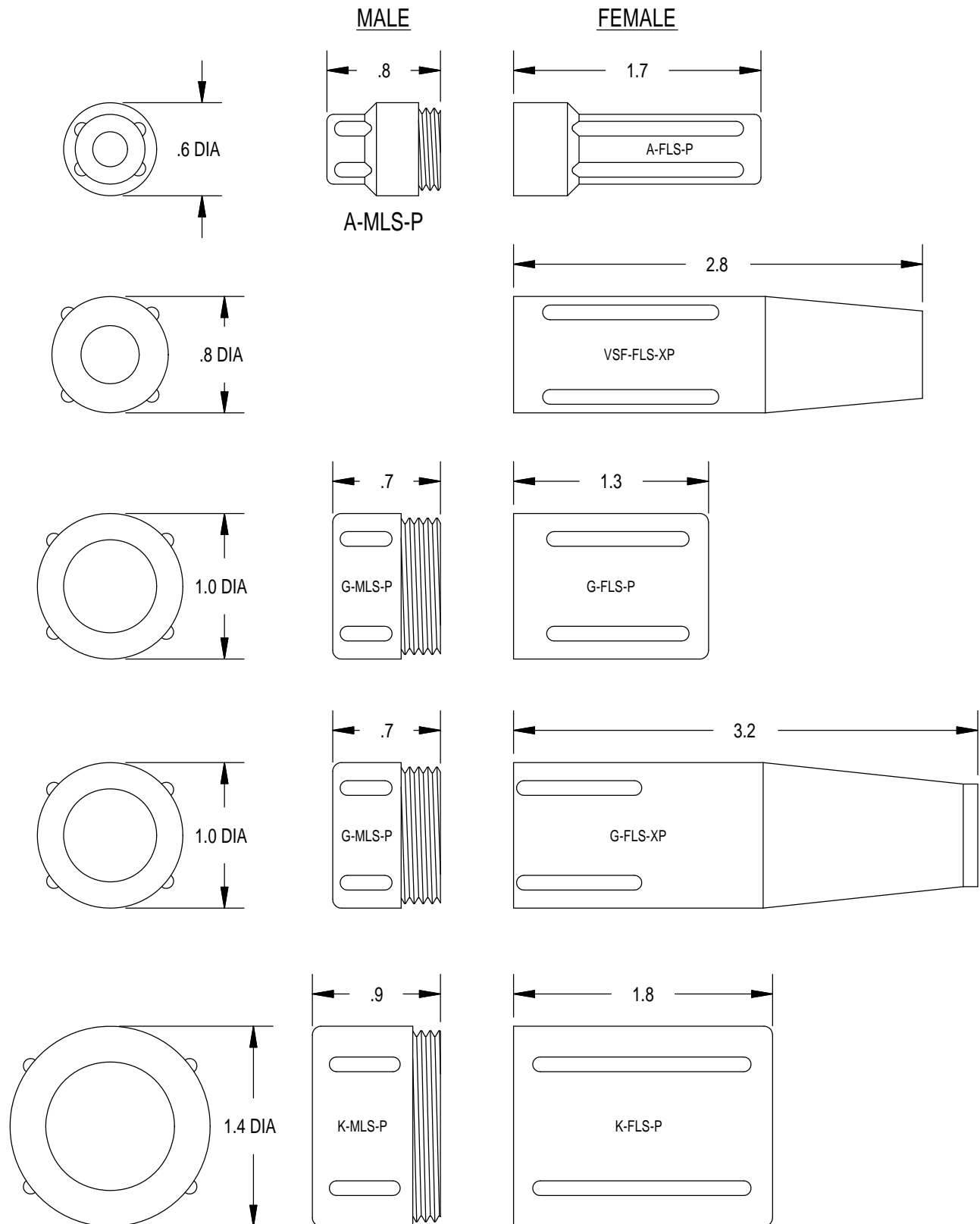

LOCKING SLEEVES

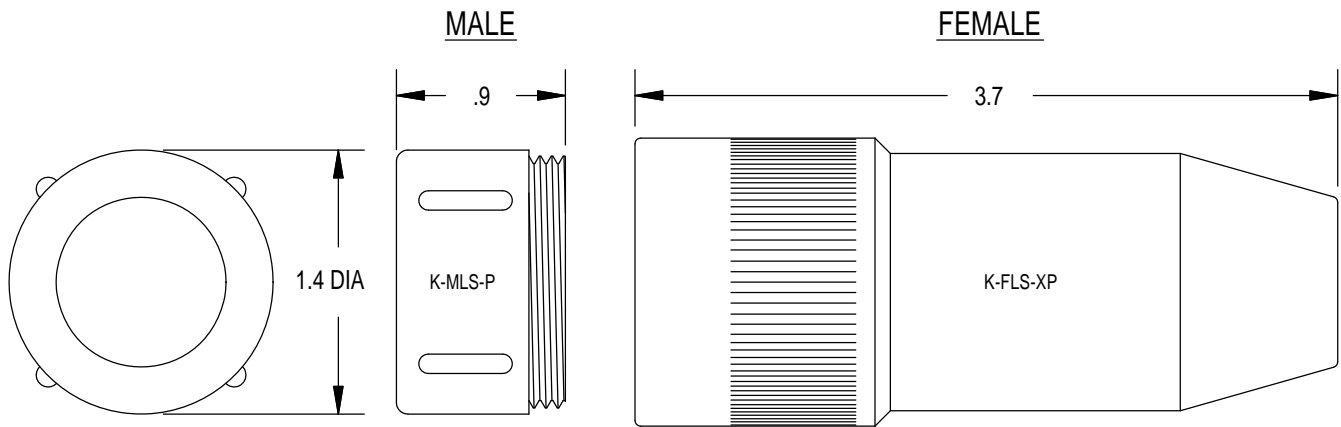

NOTE: XP is recommended to reduce conductor to contact fatigue.

STAINLESS STEEL LOCKING SLEEVES

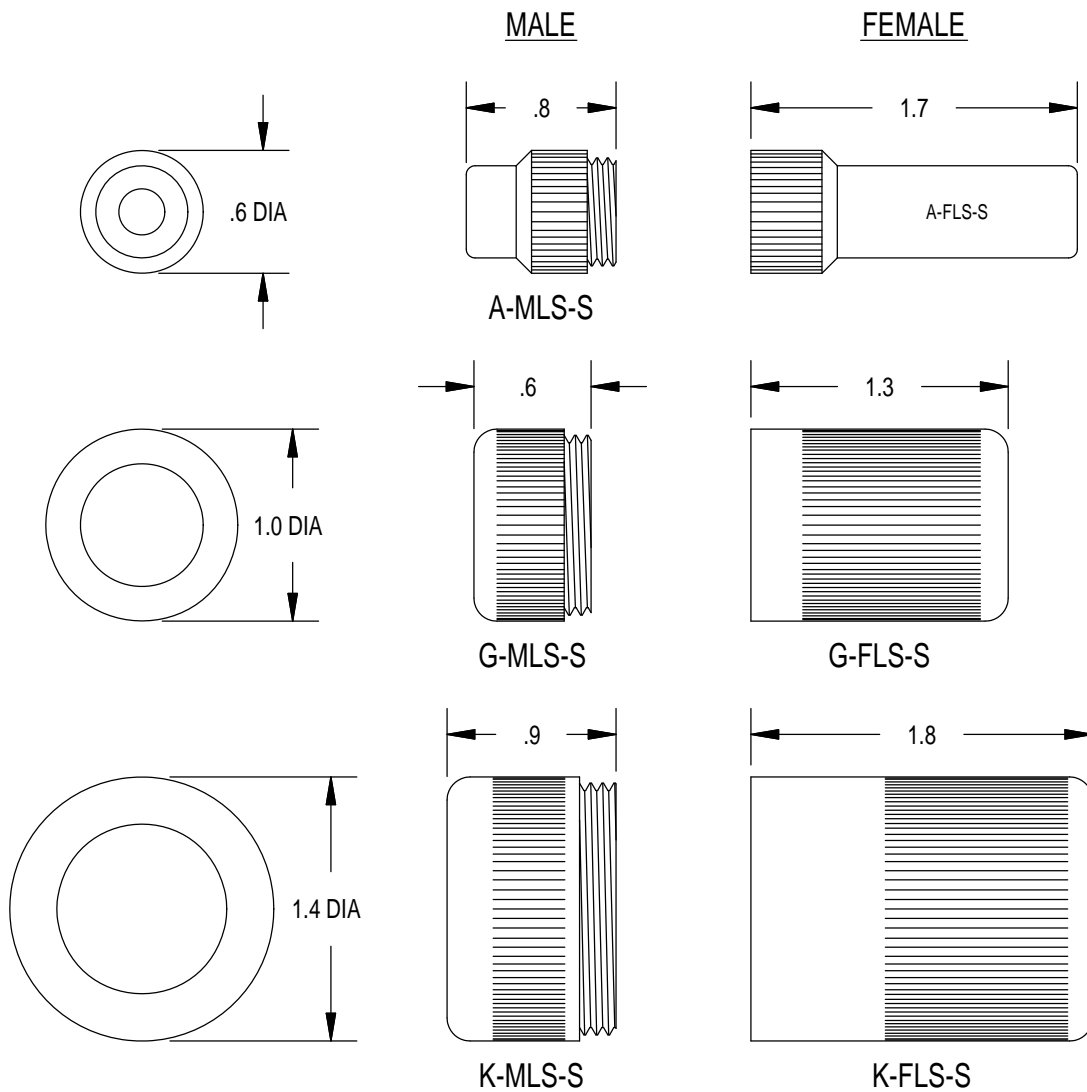

THIS PAGE INTENTIONALLY LEFT BLANK

DESCRIPTION AND MATERIAL	<ul style="list-style-type: none">• Identical to XS-RM connectors except sockets replace pins.• Molded neoprene or polyurethane (for G-size) inline connectors and glass reinforced epoxy, stainless steel or aluminum bulkhead connectors.• One to twelve contacts.• Up to 600 VDC (For higher voltages, contact factory).• Up to 10,000 PSI in mated condition.• Bulkhead connector design open face pressure rated to 5000 psi.• Contacts gold plated per MIL-G-45204.• Field installable connectors with locking sleeve available.• Field installable connectors have a removable tapered boot for easy access to solder pots during field installation.
CABLE	<ul style="list-style-type: none">• Connector's amperage and voltage may be limited by amperage and voltage rating of cable to which connector is molded.• Inline connectors in this series, except field installables, are provided on a standard 24" length of 18 AWG SO cable unless otherwise specified.(Note:VMA provided on 24" length of 20 AWG.)
USES	<ul style="list-style-type: none">• Light to medium duty applications.• Hazardous environment.• Power transmission.• Signal telemetry.• FIB - Field installable applications.
GUIDELINES	<ul style="list-style-type: none">• All mounting surfaces require a 32 finish.• Accomplish mating with minimum twisting and flexing.• Align indexes.• Because sockets replace pins in this series, there is less damage potential in unplugged conditions.• FS can trap water (suggest flush with alcohol and blow dry).• Lubricate MP mating side with 3M Silicone Lubricant or Dow Corning #111 Valve Lubricant or equivalent.• Lubricate o-rings with Dow Corning #111 Valve Lubricant or equivalent.• Avoid o-ring cuts and nicks.• Replace o-rings when re-using connectors.• Avoid contact with noxious solvents.• Elastomers can be seriously degraded if exposed to direct sunlight or high ozone levels for extended periods of time.

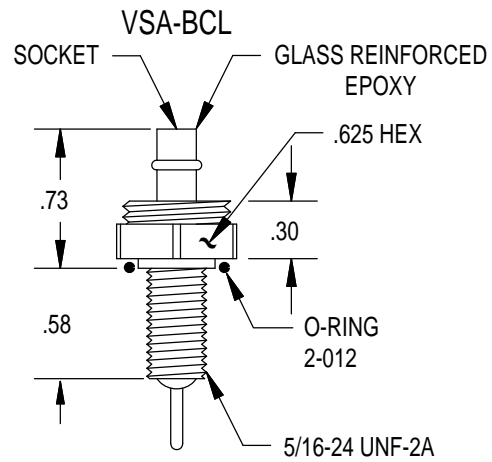
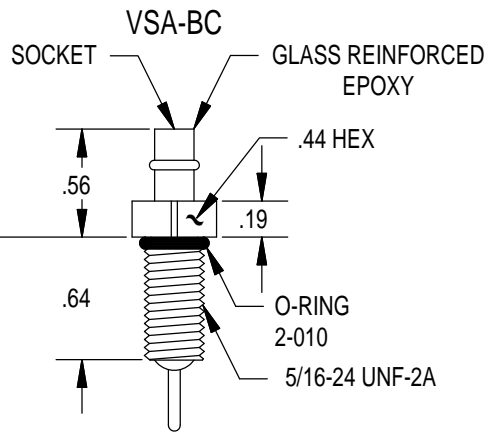
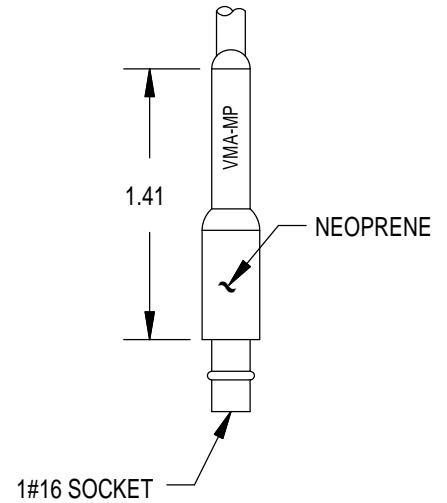
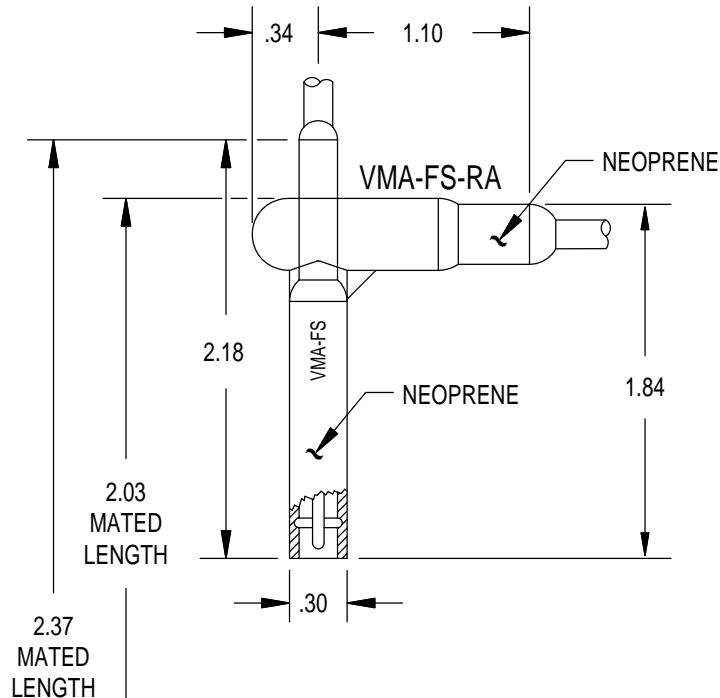

MOUNTING INSTRUCTIONS VSA-BC

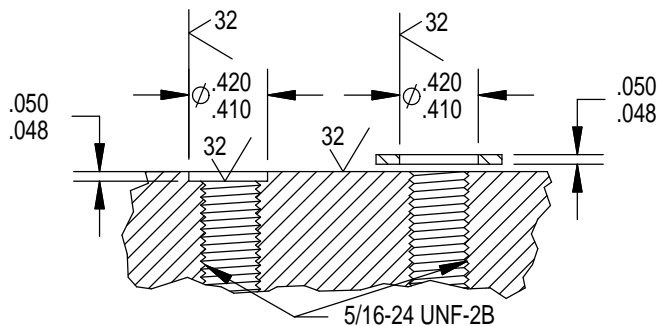

MOUNTING INSTRUCTIONS VSA-BCL

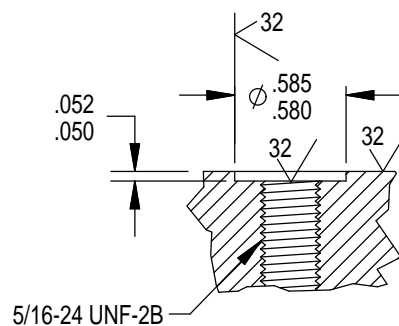

VMA-FS W/LOCKING SLEEVE

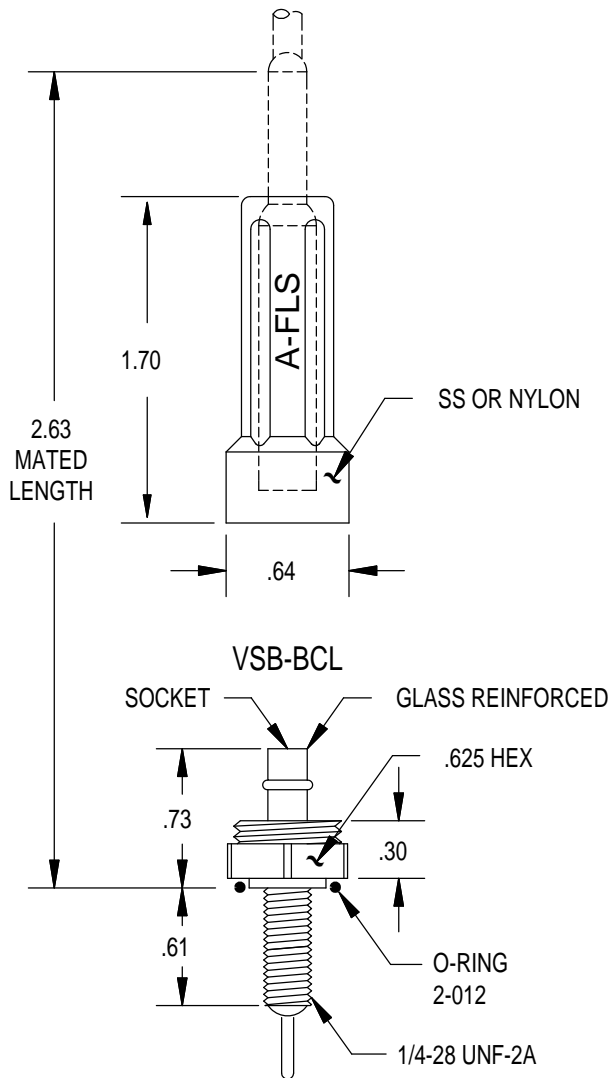

SLIP ON SERIES

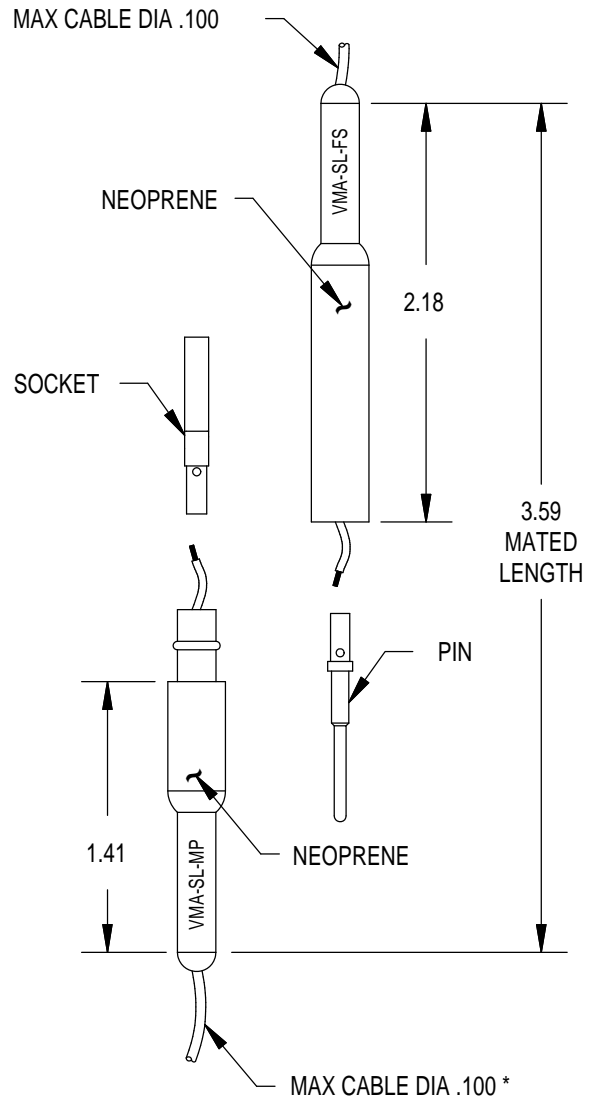

MOUNTING TORQUE FOR VSA-BC	not to exceed 5 in lbs	MOUNTING TORQUE FOR VSA-BCL	not to exceed 8 in lbs
MOUNTING TORQUE FOR VSB-BCL	not to exceed 6 in lbs	MATED PRESSURE RATING (psi)	10,000
DUMMY PLUG FOR VSA-BC, VSA-BCL, VSB-BCL, VMA-MP		DUMMY PLUG FOR VMA-FS	
LOW PRESSURE < 4,000 psi	VMA-FSD-LP	VMA-MPD	
HIGH PRESSURE > 4,000 psi	VMA-FSD-HP		
NOTE: Locking sleeves available in plastic or stainless steel, see Tech. Bulletin 25 50. * Must specify conductor diameter when ordering slip on series.			

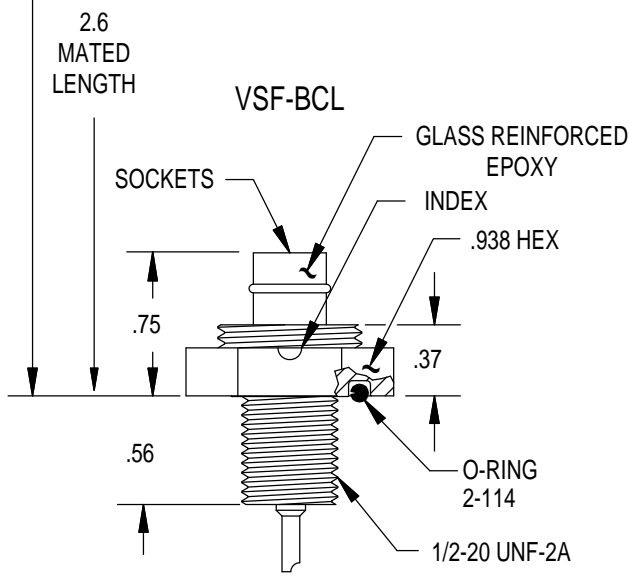
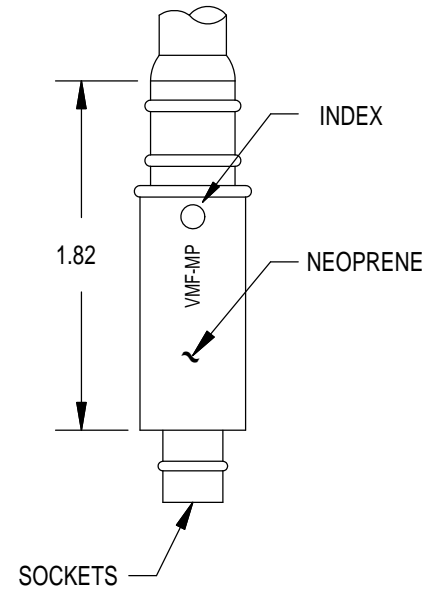
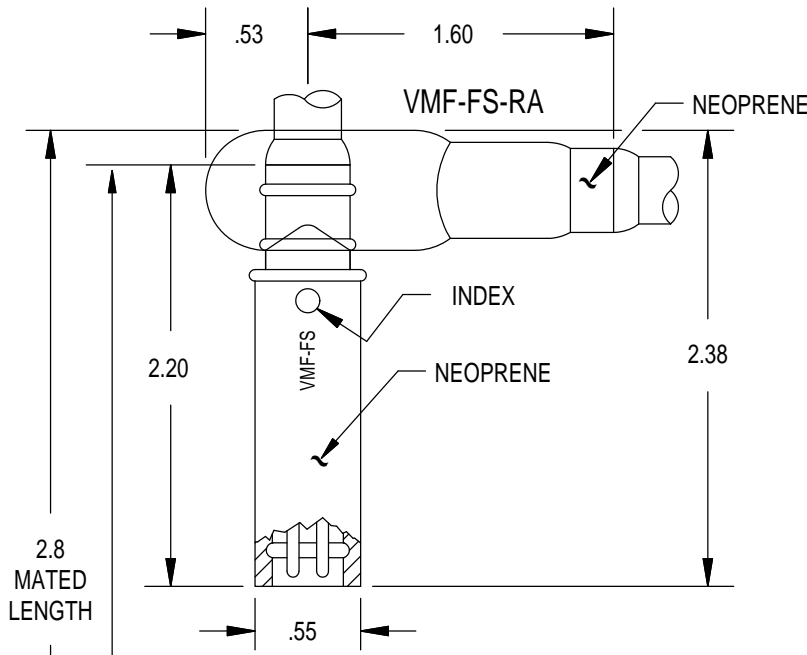

CONTACT CONFIGURATION
(BCL FACE VIEWS)

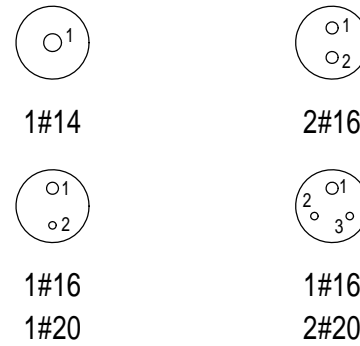

MOUNTING TORQUE FOR BCL	not to exceed 15 in lbs	MATED PRESSURE RATING (psi)	10,000
DUMMY PLUG FOR VSF-BCL, VMF-MP		DUMMY PLUG FOR VMF-FS	
LOW PRESSURE < 4,000 psi	VMF-FSD-LP	VMF-*-MPD	
HIGH PRESSURE > 4,000 psi	VMF*-FSD-HP		
NOTE: Locking sleeves available in plastic, see Technical Bulletin 25 50. * Please specify number of contacts.			

THIS PAGE INTENTIONALLY LEFT BLANK

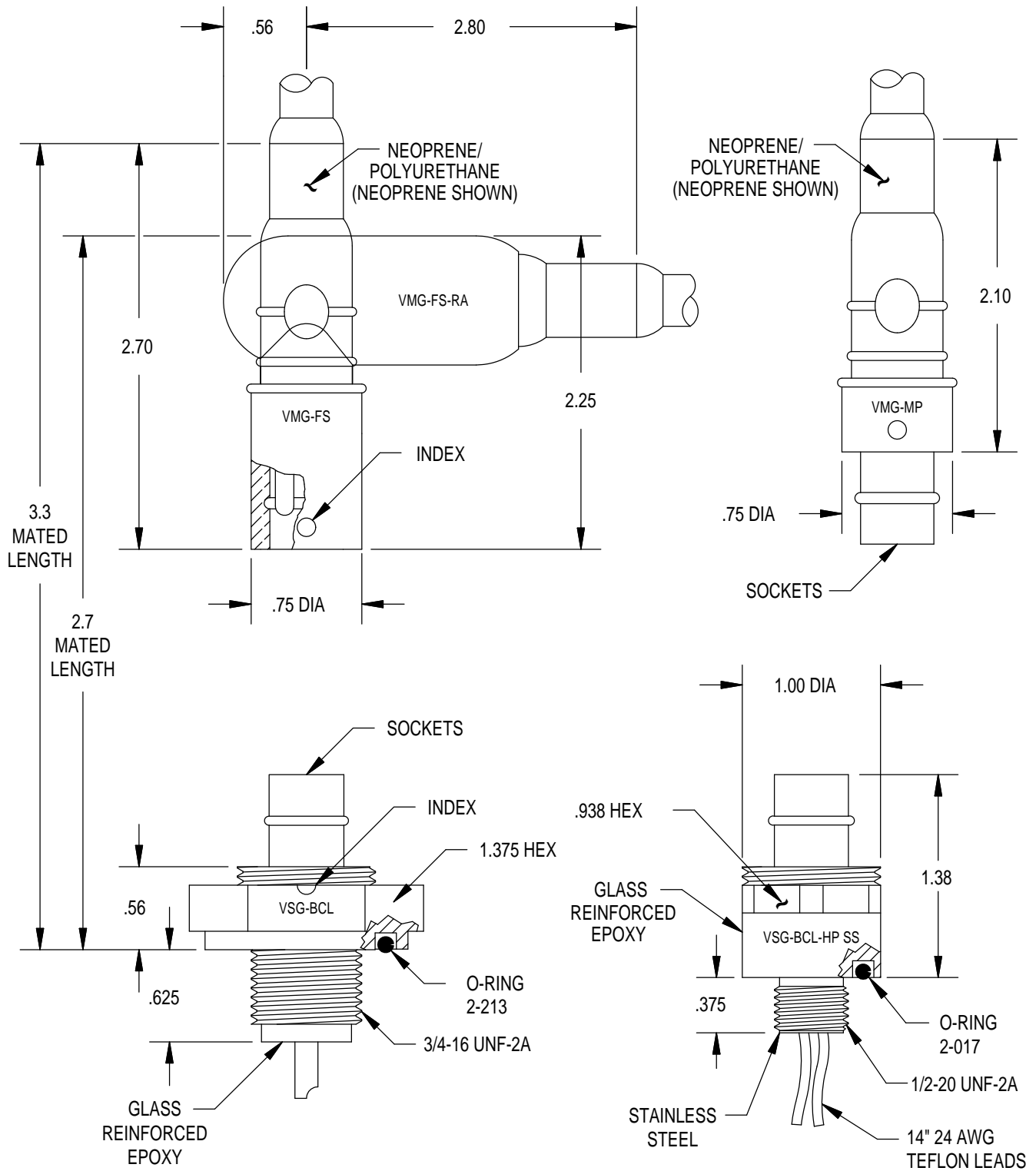

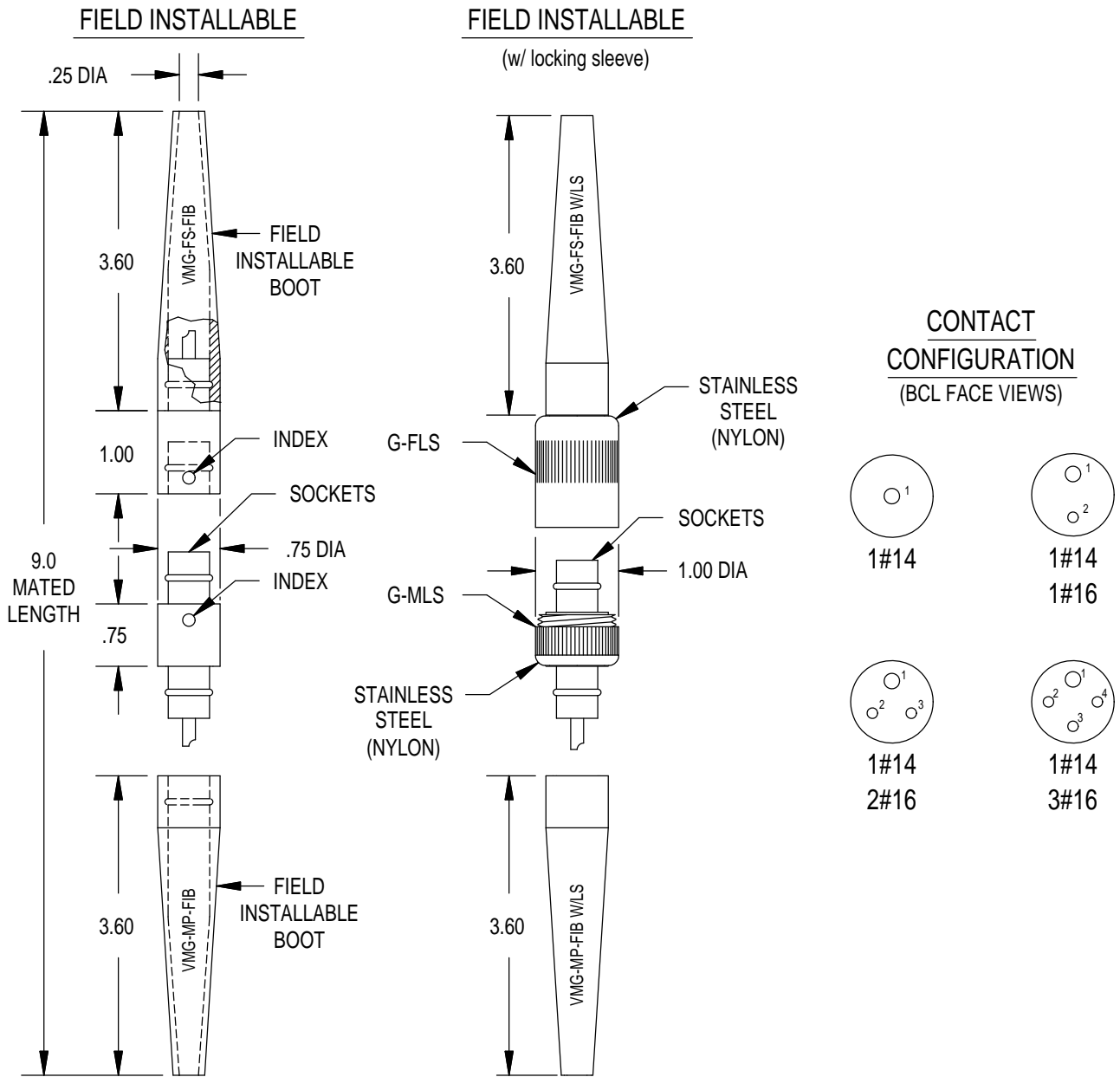

MOUNTING TORQUE FOR VSG-BCL	not to exceed 70 in lbs	MATED PRESSURE RATING (psi) FOR VSG-BCL	10,000
DUMMY PLUG FOR VSG-BCL/BCL HP SS/PBC/PBCL/PBCLM, VMG-MP		DUMMY PLUG FOR VMG-FS	
LOW PRESSURE < 4,000 psi	VMG-FSD-LP	VMG*-MPD	
HIGH PRESSURE > 4,000 psi	VMG* -FSD-HP		
NOTE: Locking sleeves available in plastic or stainless steel, see Technical Bulletin 25 50. * Please specify number of contacts.			

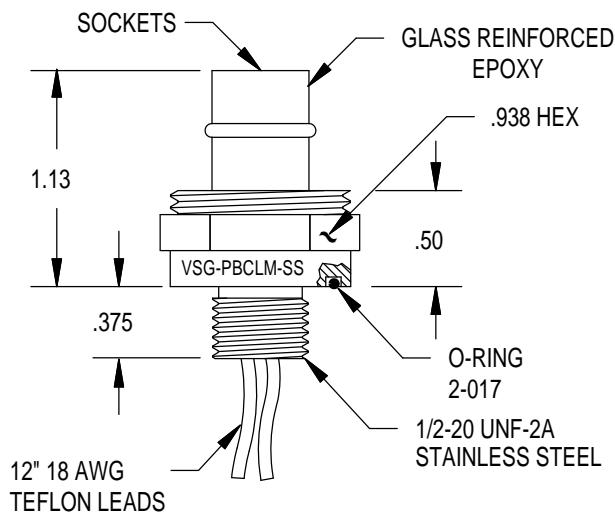
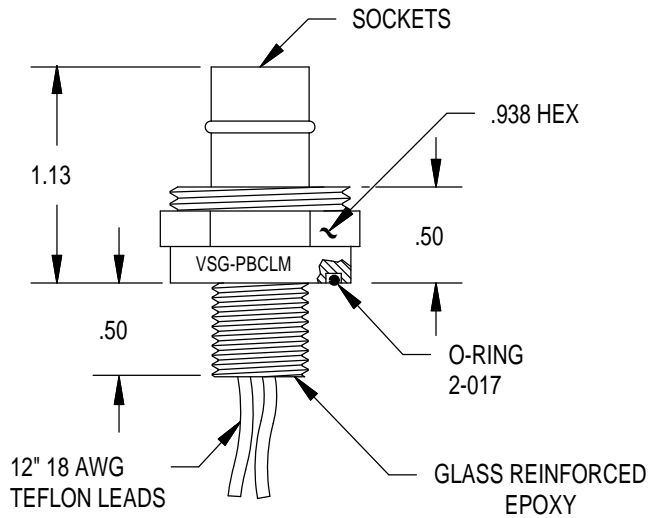
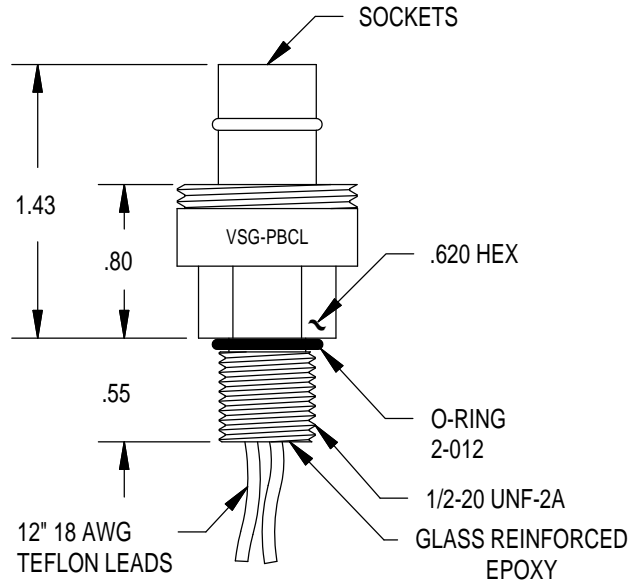
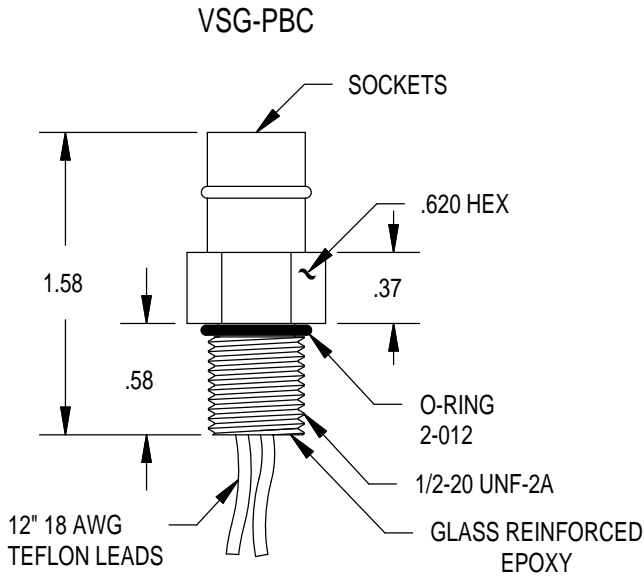

MOUNTING INSTRUCTIONS

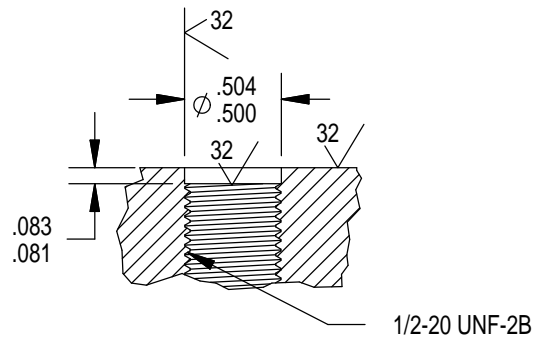

CONTACT CONFIGURATION (BCL FACE VIEWS)

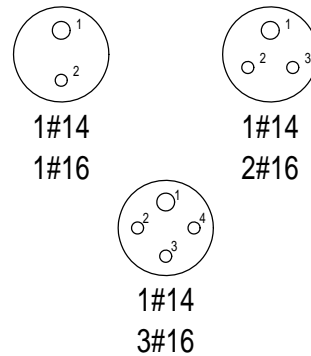

MOUNTING TORQUE FOR VSG-PBC/PBCL/PBCLM	not to exceed 15 in lbs	MATED PRESSURE RATING (psi) FOR VSG-PBC/PBCL/PBCLM	5,000
NOTE: See Technical Bulletin 25 31 for dummy specifications.			

THIS PAGE INTENTIONALLY LEFT BLANK

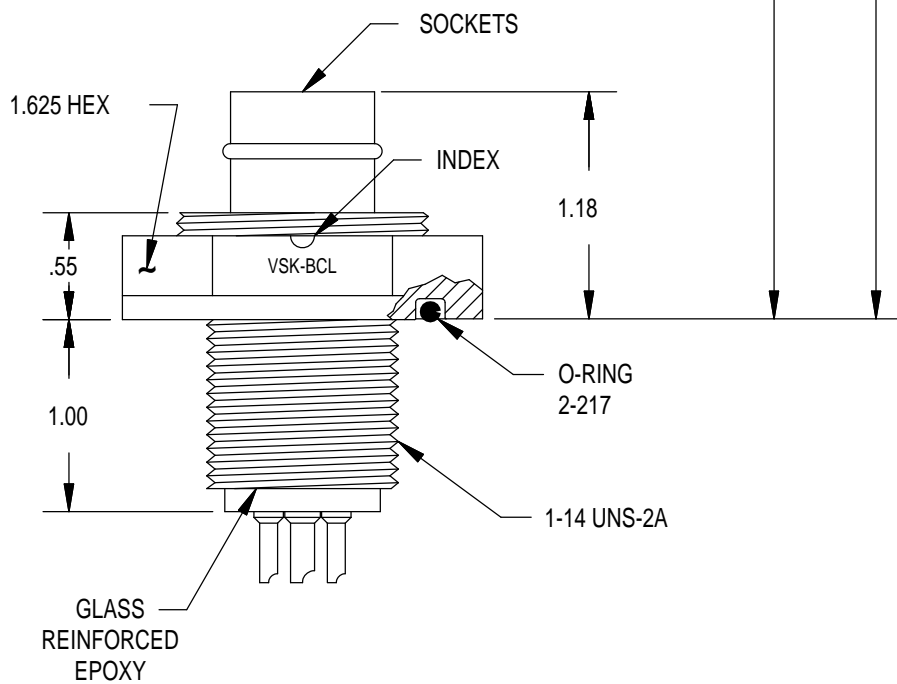
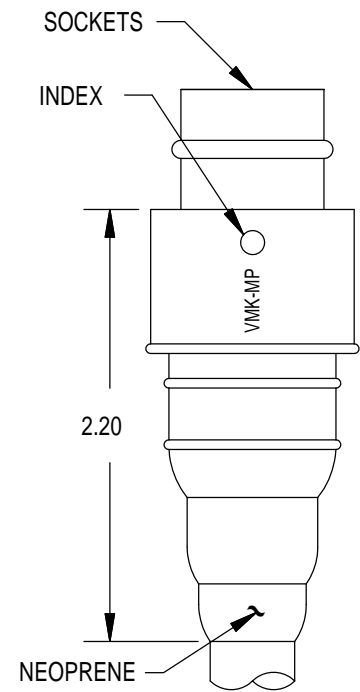
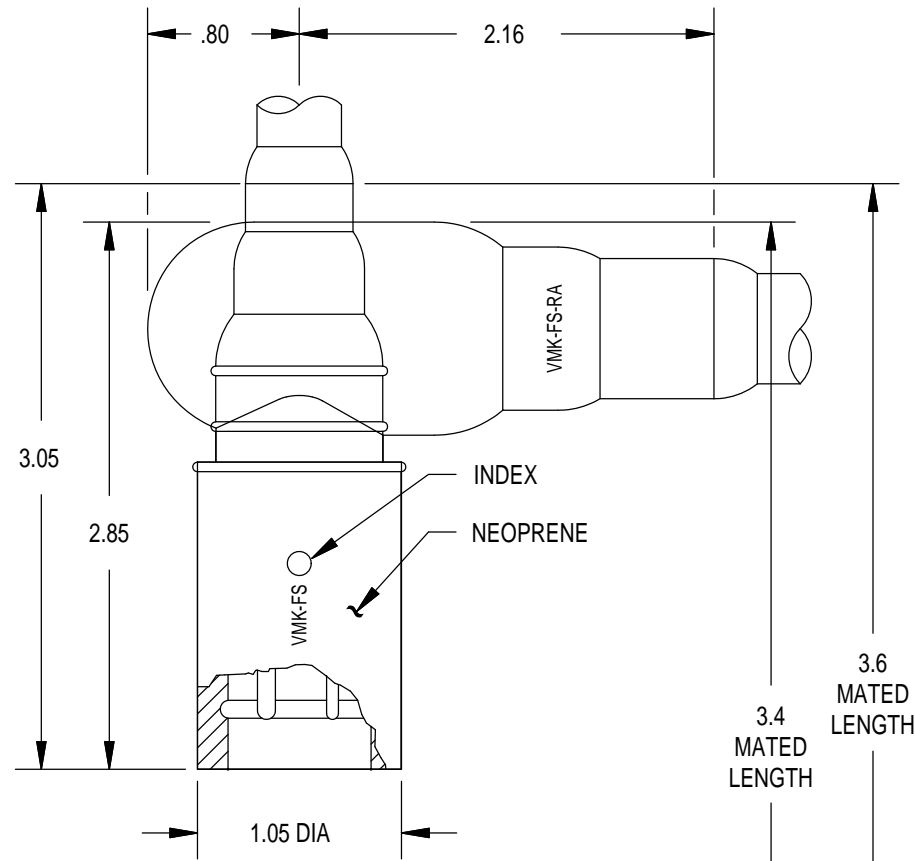

FIELD INSTALLABLE

CONTACT CONFIGURATION
(FACE VIEW-BCL)

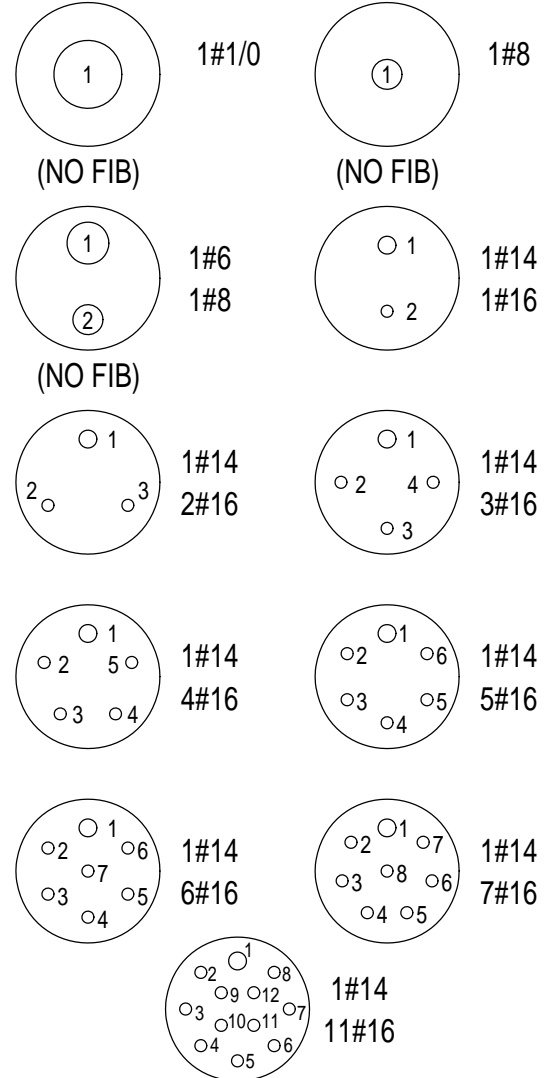
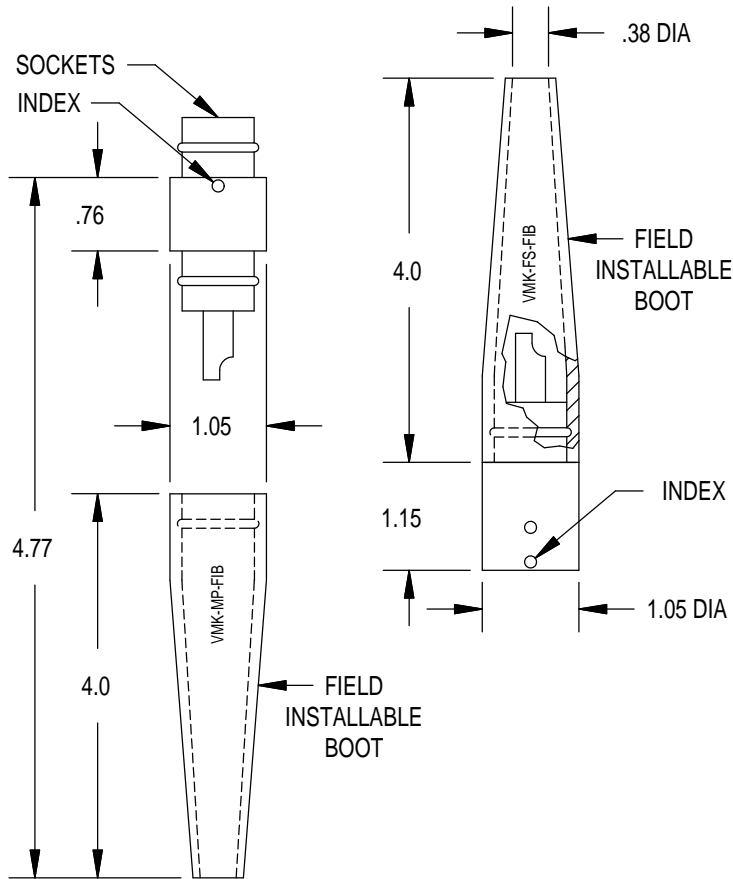

MOUNTING TORQUE FOR VSK-BCL	not to exceed 130 in lbs	MATED PRESSURE RATING (psi) FOR VSK-BCL	10,000
DUMMY PLUG FOR VSK-BCL, VMK-MP		DUMMY PLUG FOR VMK-FS	
LOW PRESSURE < 4,000 psi	VMK-FSD-LP	VMK*-MPD	
HIGH PRESSURE > 4,000 psi	VMK*-FSD-HP		
NOTE: Locking sleeves available in plastic or stainless steel, see Technical Bulletin 25 50. * Please specify number of contacts.			

LOCKING SLEEVES

PLASTIC LOCKING SLEEVES

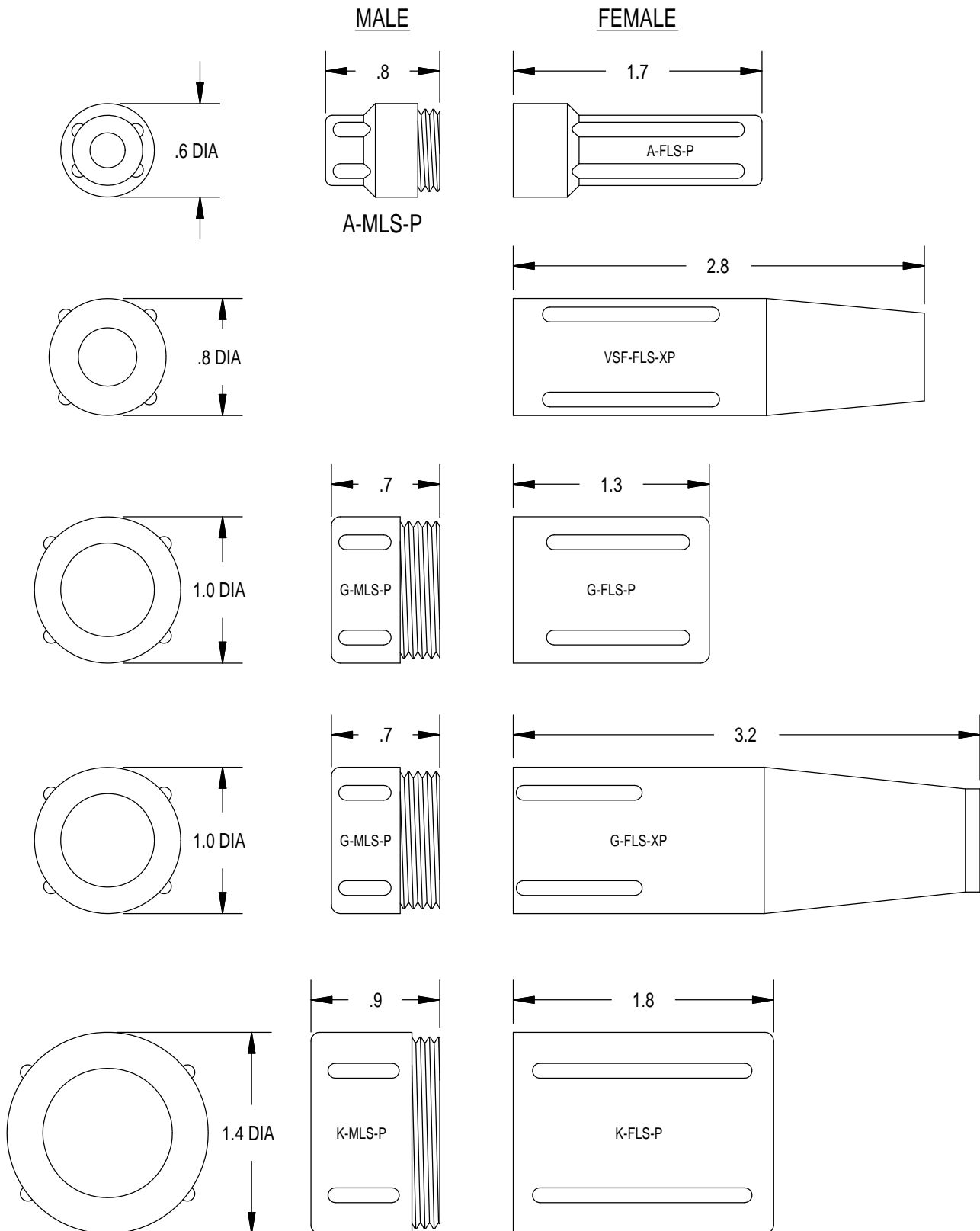

THIS PAGE INTENTIONALLY LEFT BLANK

LOCKING SLEEVES

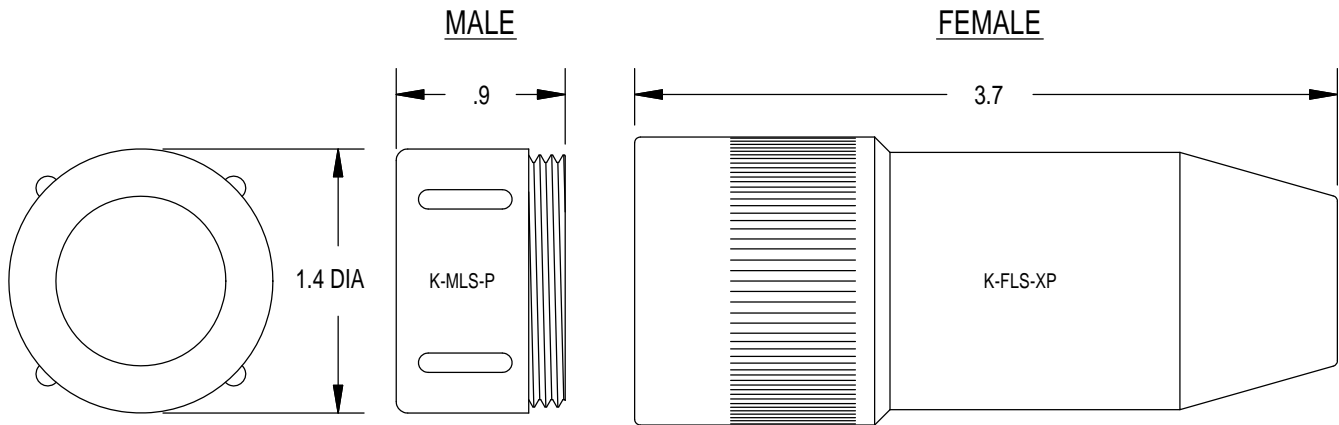

NOTE: XP is recommended to reduce conductor to contact fatigue.

STAINLESS STEEL LOCKING SLEEVES

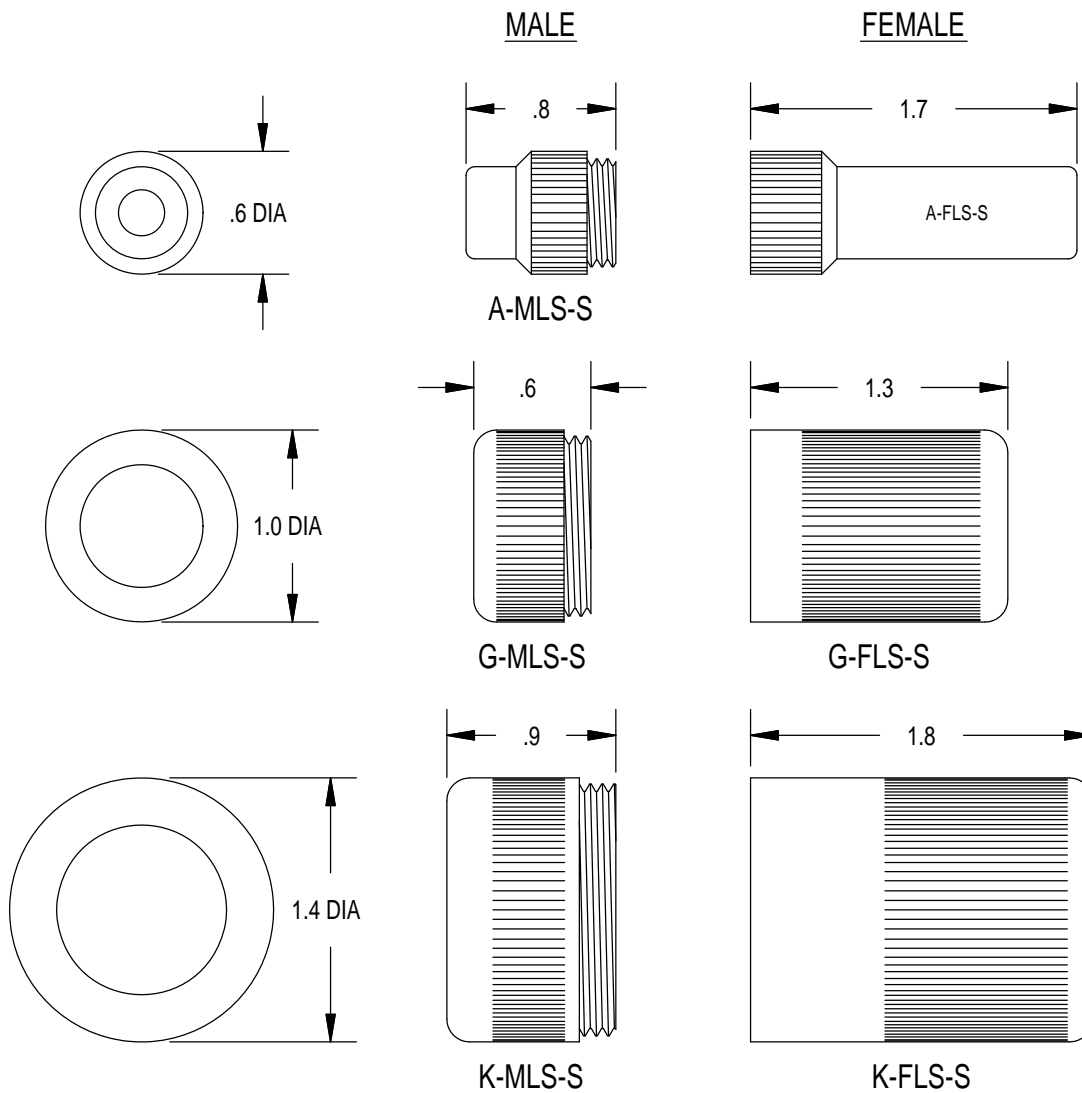

DESCRIPTION AND MATERIAL	<ul style="list-style-type: none">• Molded glass reinforced epoxy.• One to 36 contacts.• 200 VDC to 600 VDC (higher voltage ratings available upon request).• Up to 20,000 PSI in mated condition.• Bulkhead connector design open face pressure rated to 5000 psi.• Contacts gold plated per MIL-G-45204.• XS-CCR/CCP connectors can be overmolded with polyurethane or neoprene.• Conductor insulation and jacket material of specified cable determines overmold material.
CABLE	<ul style="list-style-type: none">• Connector's amperage and voltage may be limited by amperage and voltage rating of cable to which connector is molded.• This series is not molded to cable unless specified at the time of order.
USES	<ul style="list-style-type: none">• Medium duty applications.• Hazardous environment.• Power transmission.• Signal telemetry.• CCR used in a variety of environments where cable to cable connection is necessary.
GUIDELINES	<ul style="list-style-type: none">• All mounting surfaces require a 32 finish.• Do not exceed mounting torque specifications.• Align indexes.• Use in areas not subject to high impact to avoid chipping and cracking.• Keep o-ring grooves clean.• Avoid o-ring cuts and nicks.• Lubricate o-rings with Dow Corning #111 Valve Lubricant or equivalent.• Replace o-rings when re-using connectors.• Avoid contact with noxious solvents.• Elastomers can be seriously degraded if exposed to direct sunlight or high ozone levels for extended periods of time.

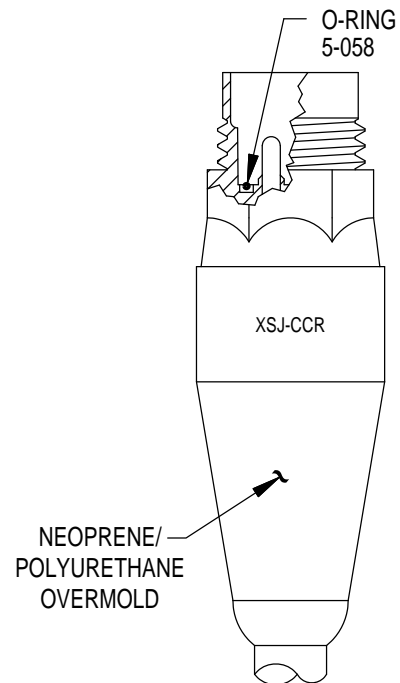
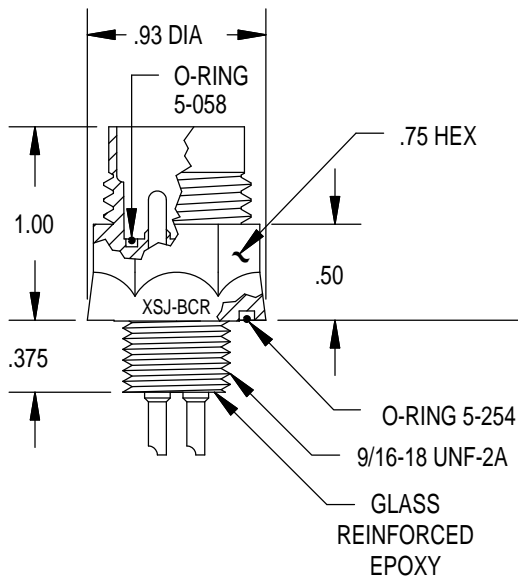
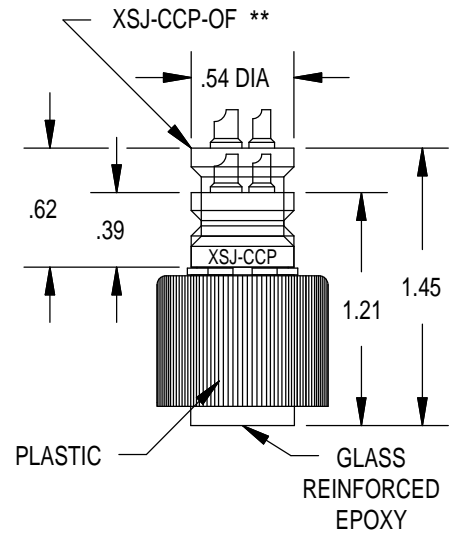
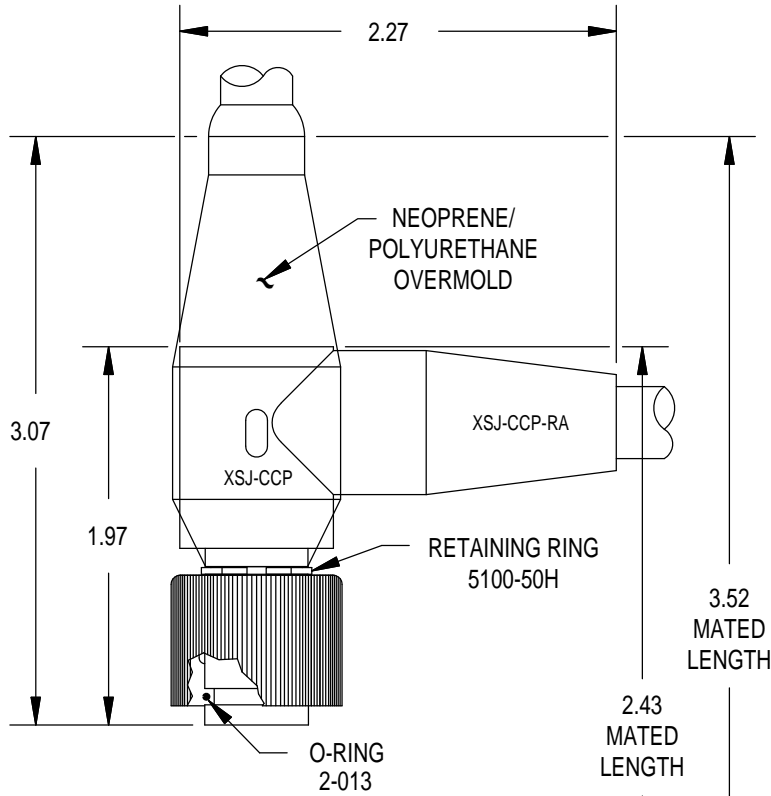

CONTACT
CONFIGURATION
(BCR FACE VIEWS)

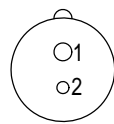

1#14
1#16
600 VDC

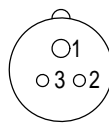

1#14
2#16
600 VDC

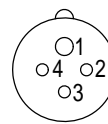

1#14
3#16
300 VDC



2#16
3#20
300 VDC



1#16
6#20
300 VDC

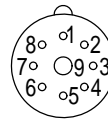

1#14
8#20
300 VDC

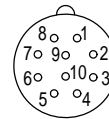

10#20
300 VDC

MOUNTING TORQUE FOR XSJ-BCR	not to exceed 20 in lbs	MATED PRESSURE RATING (psi)	10,000
DUMMY PLUG FOR XSJ-BCR/CCR	XSJ*-SCP	DUMMY PLUG FOR XSJ-CCP	XSJ-SCR
<p>NOTE: CCP/CCR are not terminated to cable unless specified. * Please specify number of contacts. ** Extended backshell for Oil Filled assemblies.</p>			

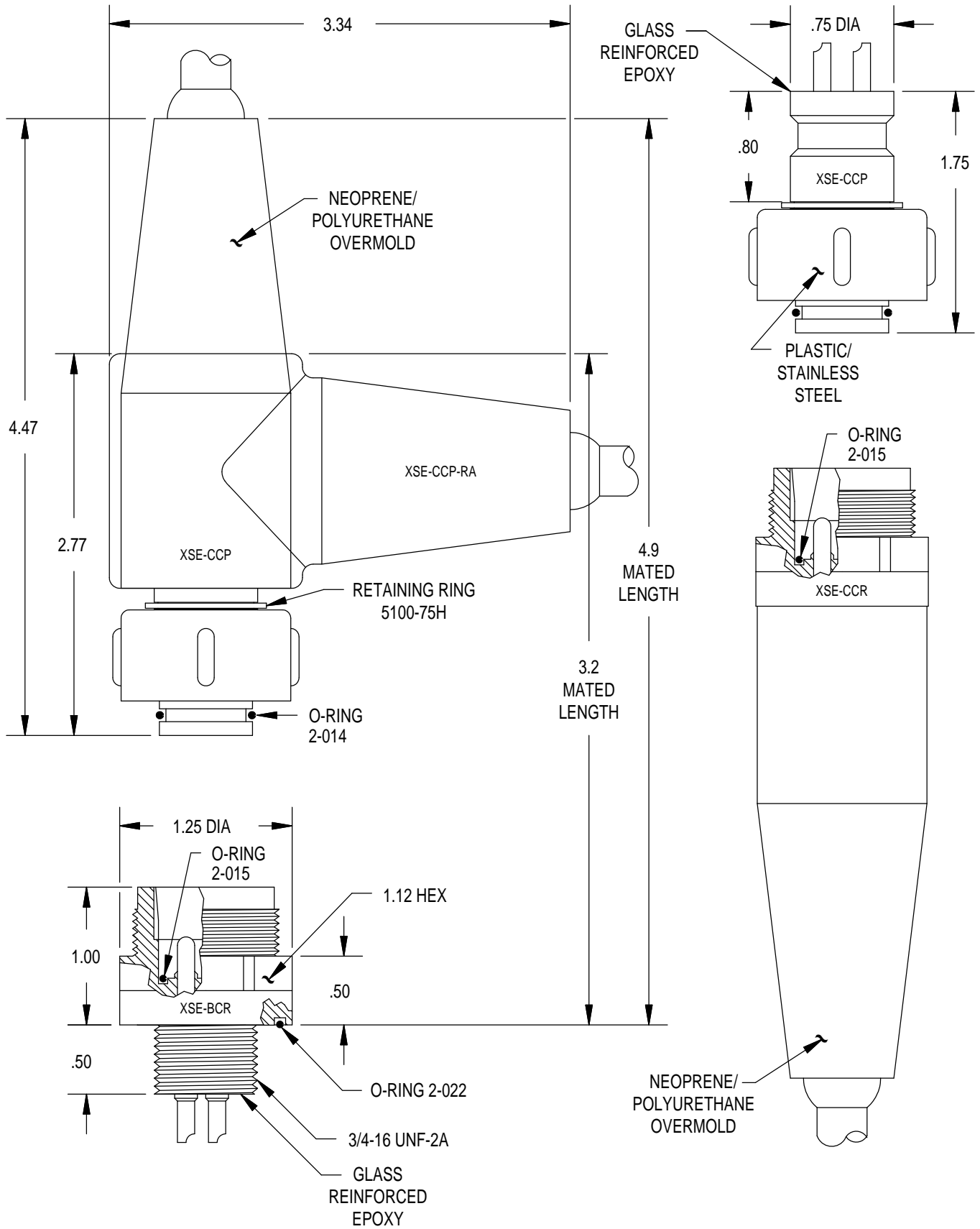

CONTACT
CONFIGURATION
(BCR FACE VIEWS)

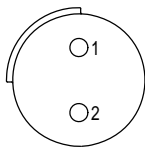

2#14
800 VDC

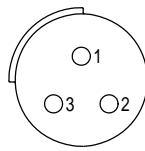

3#14
700 VDC

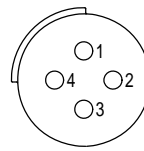

4#14
600 VDC

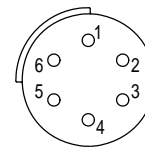

6#16
500 VDC

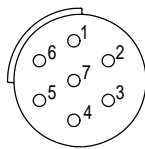

7#16
500 VDC

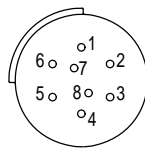

8#20
400 VDC

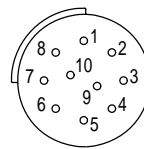

10#20
300 VDC

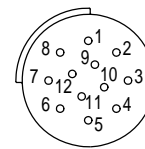

12#20
250 VDC

MOUNTING TORQUE FOR XSE-BCR	not to exceed 75 in lbs	MATED PRESSURE RATING (psi)	10,000
DUMMY PLUG FOR XSE-BCR/CCR	XSE*-SCP	DUMMY PLUG FOR XSE-CCP	XSE-SCR
NOTE: CCP/CCR are not terminated to cable unless specified. * Please specify number of contacts.			

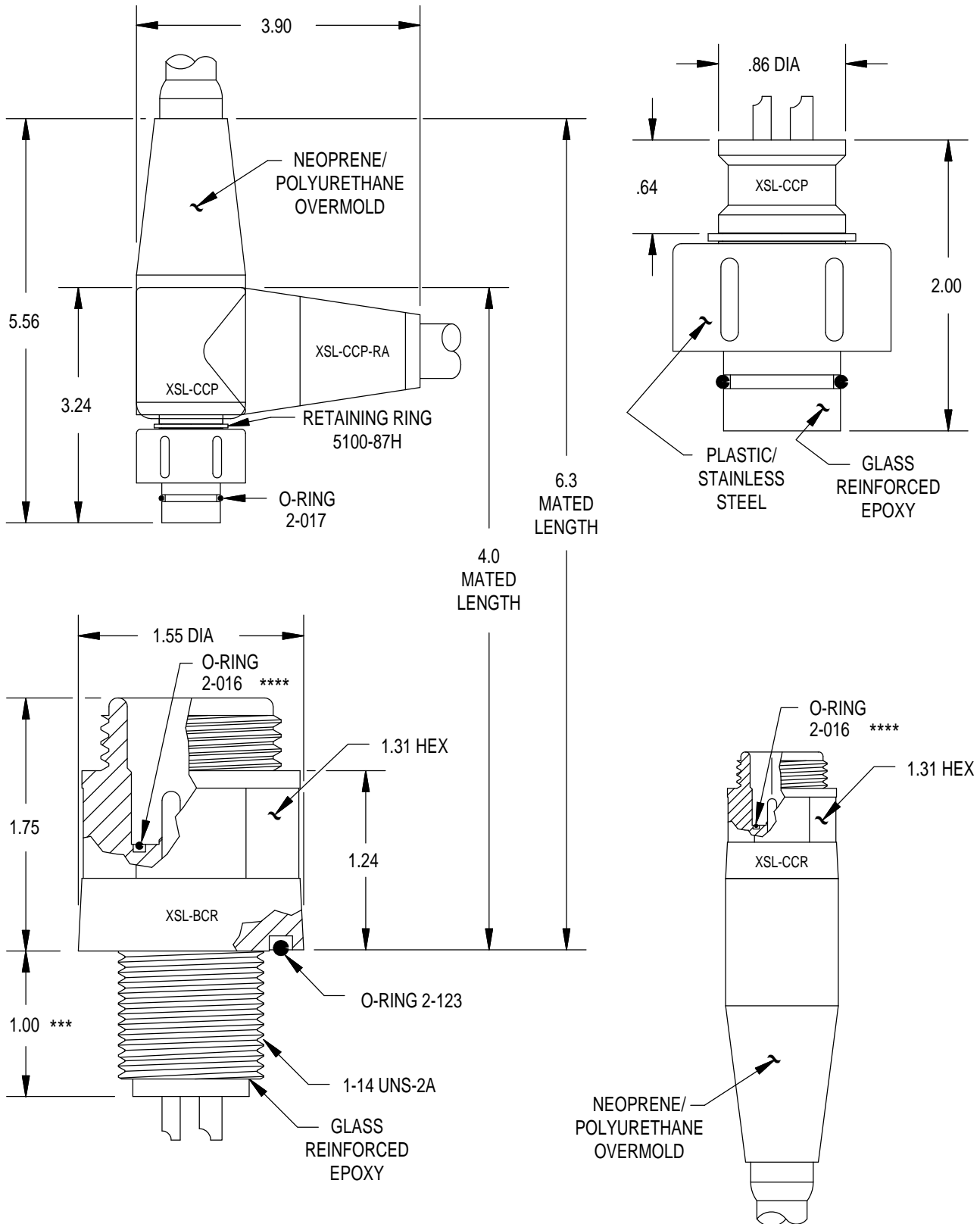

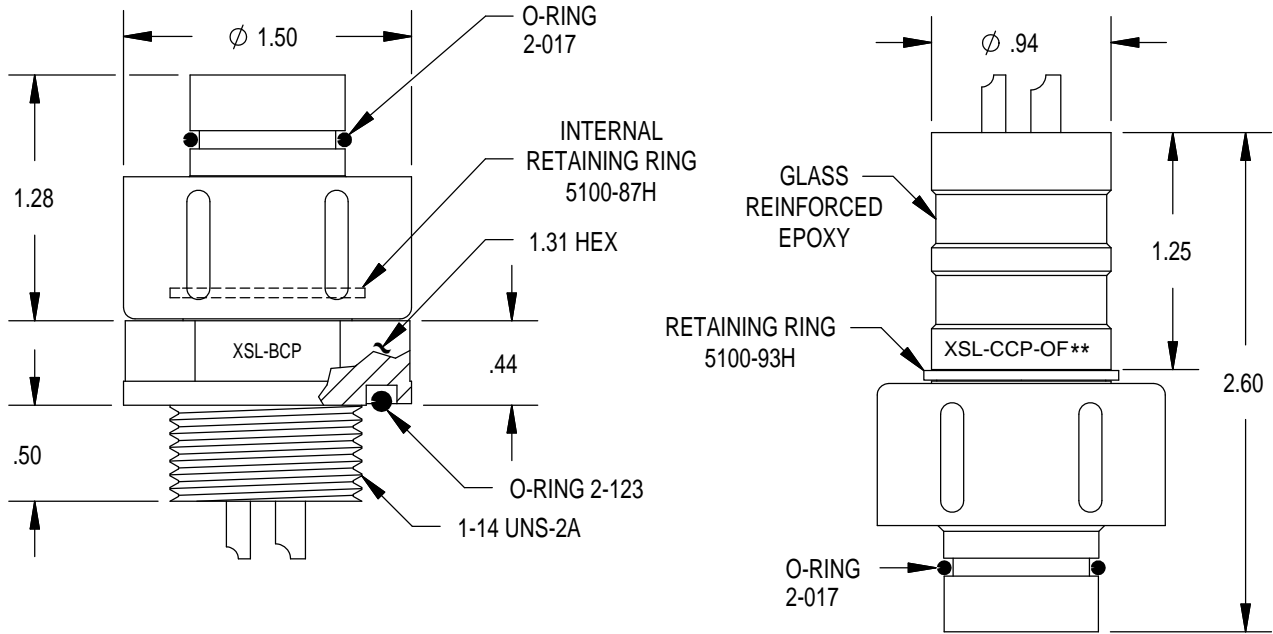

CONTACT CONFIGURATION
(BCR FACE VIEWS)

NOTE: Please specify narrow (.125) or wide (.250) key when ordering.

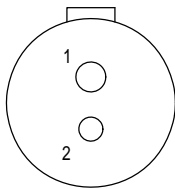

1#8/1#10
600 VDC

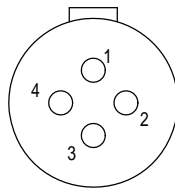

4#10
600 VDC

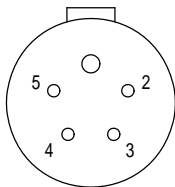

1#14/4#16
500 VDC

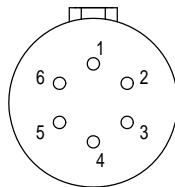

6#16
500 VDC

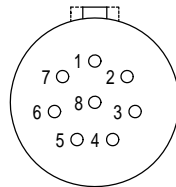

8#16
500 VDC

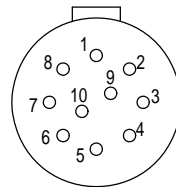

10#16
400 VDC

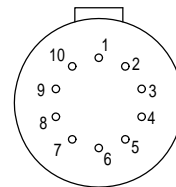

(PBOF)10#20
200 VDC

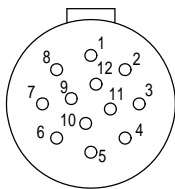

12#16
200 VDC

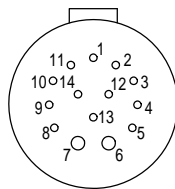

2#6/12#20
600 VDC

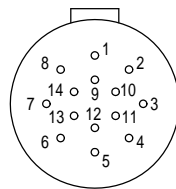

14#20
200 VDC

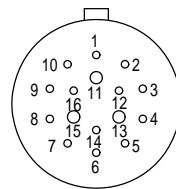

3#16/13#20
200 VDC

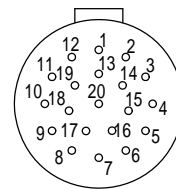

20#20
200 VDC

MOUNTING TORQUE FOR XSL-BCR/BCP	not to exceed 130 in lbs	MATED PRESSURE RATING (psi)	20,000
DUMMY PLUG FOR XSL-BCR/CCR	XSL-* -SCP	DUMMY PLUG FOR XSL-CCP/BCP/CCP/CCP-OF	XSL-* -SCR

NOTE: CCP/CCR are not terminated to cable unless specified.
 * Please specify number of contacts.
 ** Extended backshell for Oil Filled assemblies.
 *** Also available in .50 thread length, 5-12 contacts only.
 **** XSL-20-BCR, XSL-20-CCR and XSL-20-SCR use o-ring 5-254.

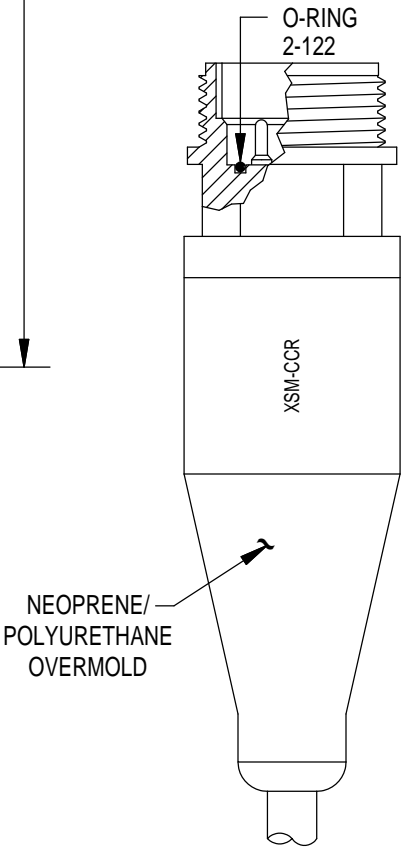
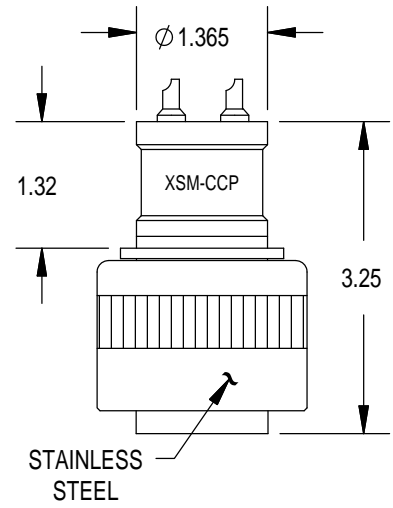
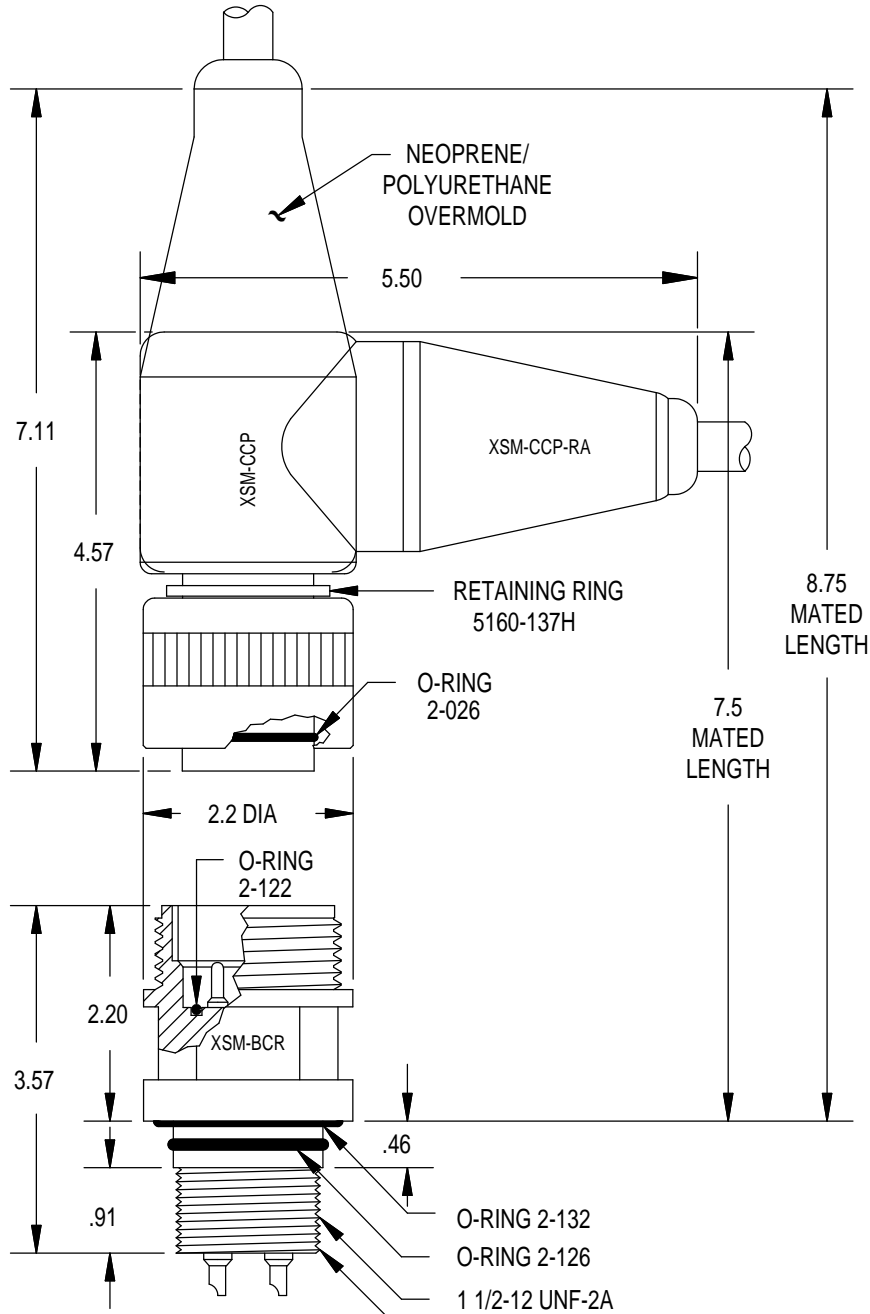

MOUNTING DETAIL

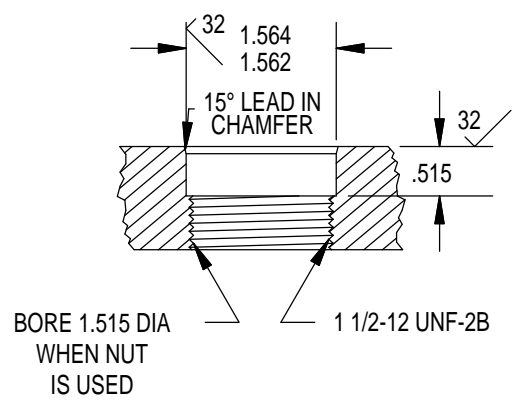

CONTACT
CONFIGURATION
(BCR FACE VIEWS)

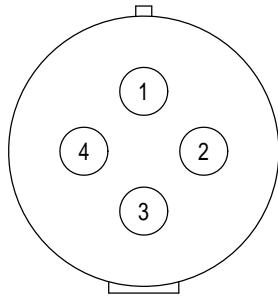

4#6
600 VDC

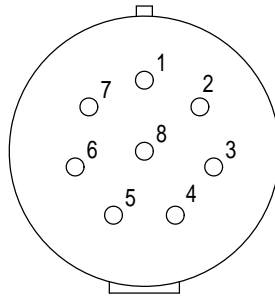

8#14
600 VDC

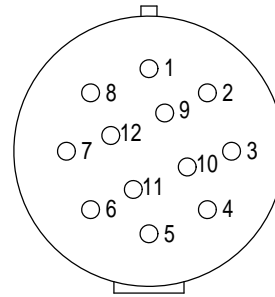

12#14
600 VDC

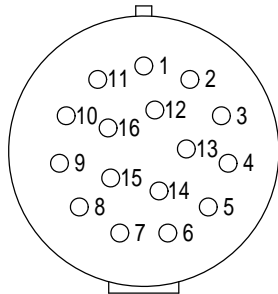

16#14
600 VDC

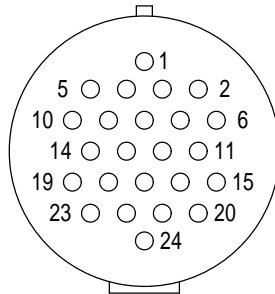

24#16
400 VDC

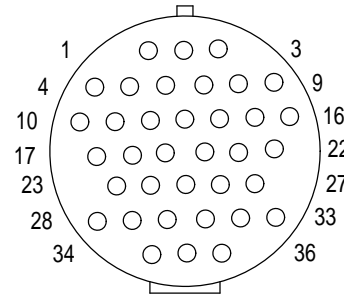

36#16
400 VDC

MOUNTING TORQUE FOR BCR	not to exceed 200 in lbs	MATED PRESSURE RATING (psi)	10,000
DUMMY CAP FOR BCR/CCR	XSM-*SCP	DUMMY CAP FOR CCP	XSM-SCR
NOTE: CCP/CCR are not terminated to cable unless specified. * Please specify number of contacts.			

THIS PAGE INTENTIONALLY LEFT BLANK

DESCRIPTION AND MATERIAL	<ul style="list-style-type: none">• 316 stainless steel passivated per QQ-P-35 Type VI with naval bronze engaging nut.• Optional material is (MSA) 6061-T6 Aluminum, hard anodized per MIL-A-8625, Type III, Class 2.• Special alloys are available upon request (contact factory).• Contains a removable glass reinforced epoxy insert (with the exception of the MSSJ/MSAJ).• One to 96 contacts.• Up to 600 VDC. Up to 5000 VDC using high voltage insert.• From 10,000 PSI to 20,000 PSI in mated condition (higher pressure rating available using special alloy metal shell; please contact factory).• Bulkhead connector design open face pressure rated to 5000 psi.• MSS-CCR/CCP connectors can be overmolded with polyurethane or neoprene.• Conductor insulation and jacket material of specified cable determines overmold material.• Contacts are gold plated per MIL-G-45204.
CABLE MATERIAL	<ul style="list-style-type: none">• Connector's amperage and voltage may be limited by the amperage and voltage ratings of the cable to which the connector is molded.• This series is not molded to cable unless specified at the time of order.
USES MATERIAL	<ul style="list-style-type: none">• Heavy duty applications.• Hazardous, rugged environment.• Power transmission.• Signal telemetry.• FCR is mounted by use of six equally spaced bolts around the flange surface.• FCR is used in place of the BCR when the use of a bulkhead nut and washer is impractical.• For all open face pressures above 5,000 PSI the BCR, FCR must be back potted (please contact the factory).• The CCR is used in a variety of rugged environments where cable to cable termination is necessary.
GUIDELINES MATERIAL	<ul style="list-style-type: none">• Mounting torque should not exceed 200 in lbs. for this series.• All mounting surfaces require a 32 finish.• Align indexes.• Keep o-ring grooves clean.• Avoid o-ring cuts and nicks.• Lubricate o-rings with Dow Corning #111 Valve Lubricant or equivalent.• Replace o-rings when re-using connectors.• Avoid contact with noxious solvents.• Elastomers can be seriously degraded if exposed to direct sunlight or high ozone levels for extended periods of time.

MSSJ/MSAJ

METAL SHELL STAINLESS
STEEL / ALUMINUM SERIES

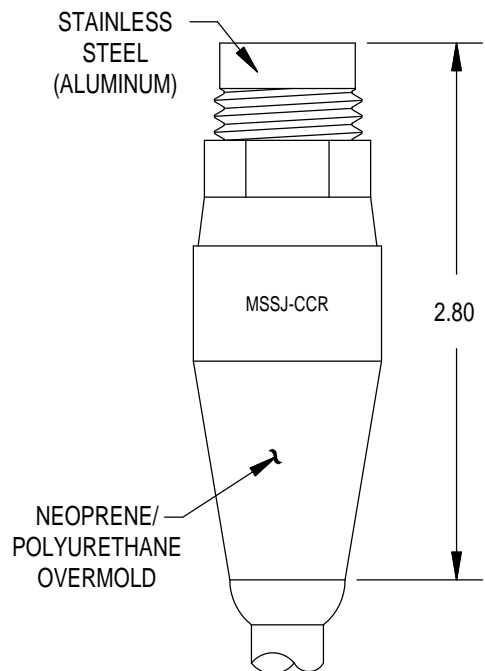
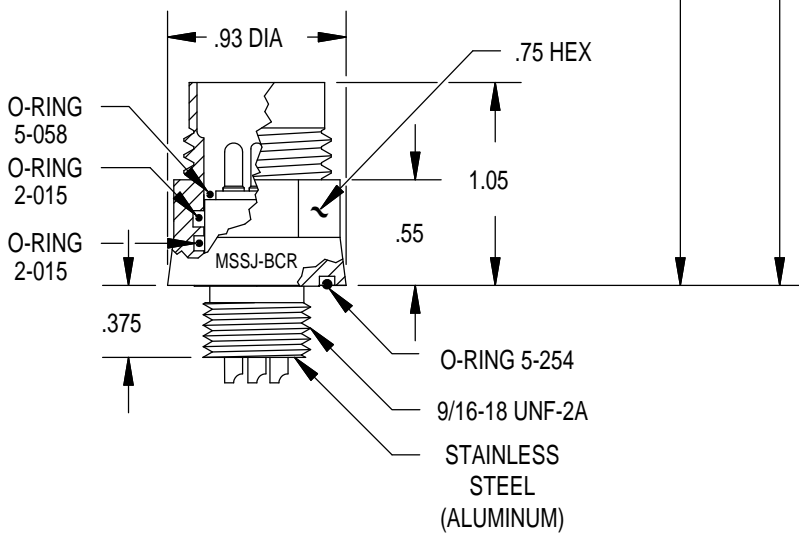
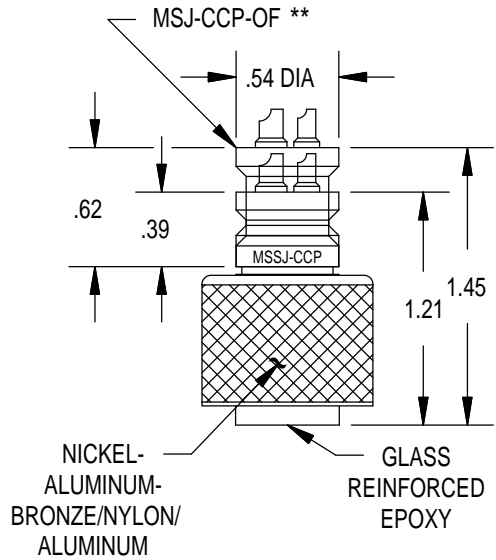
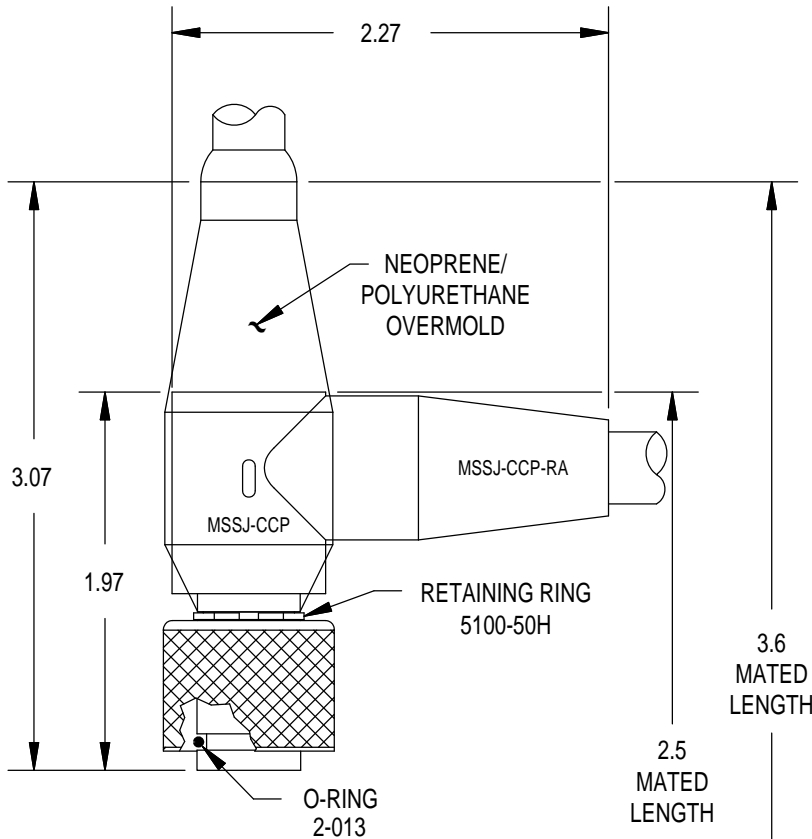

**CONTACT
CONFIGURATION**
(BCR FACE VIEWS)

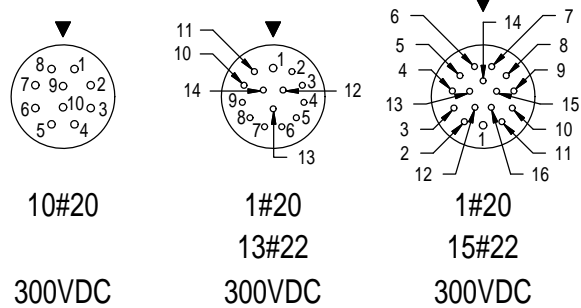
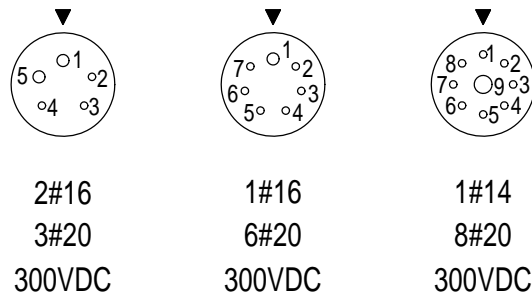
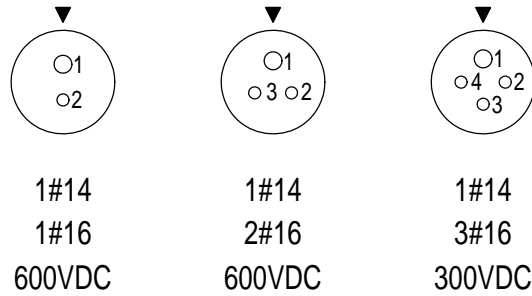
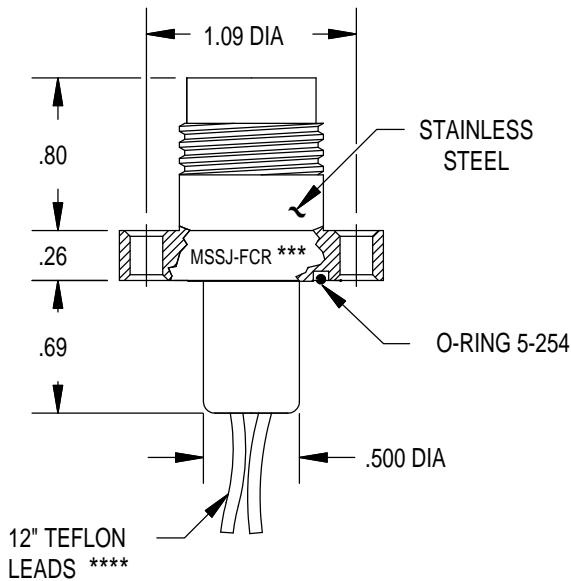
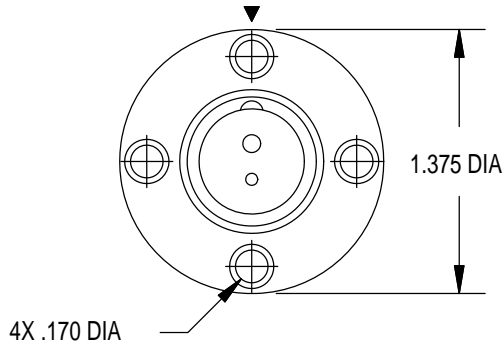

NOTE: Not available in OF.

MOUNTING TORQUE FOR MSSJ, MSAJ-BCR	not to exceed 100 in lbs	MATED PRESSURE RATING (psi)	10,000
DUMMY PLUG FOR MSSJ-BCR/FCR/CCR	MSSJ-*-SCP	DUMMY PLUG FOR MSSJ-CCP, MSAJ-CCP	MSJ-SCR (Epoxy)
DUMMY PLUG FOR MSAJ-BCR/CCR	MSAJ-*-SCP		

NOTE: CCP is not terminated to cable unless specified.

- * Please specify number of contacts.
- ** Extended backshell for Oil Filled assemblies.
- *** Internal assembly same as MSSJ/MSAJ-BCR (facing page).
- **** Solder cup version available.

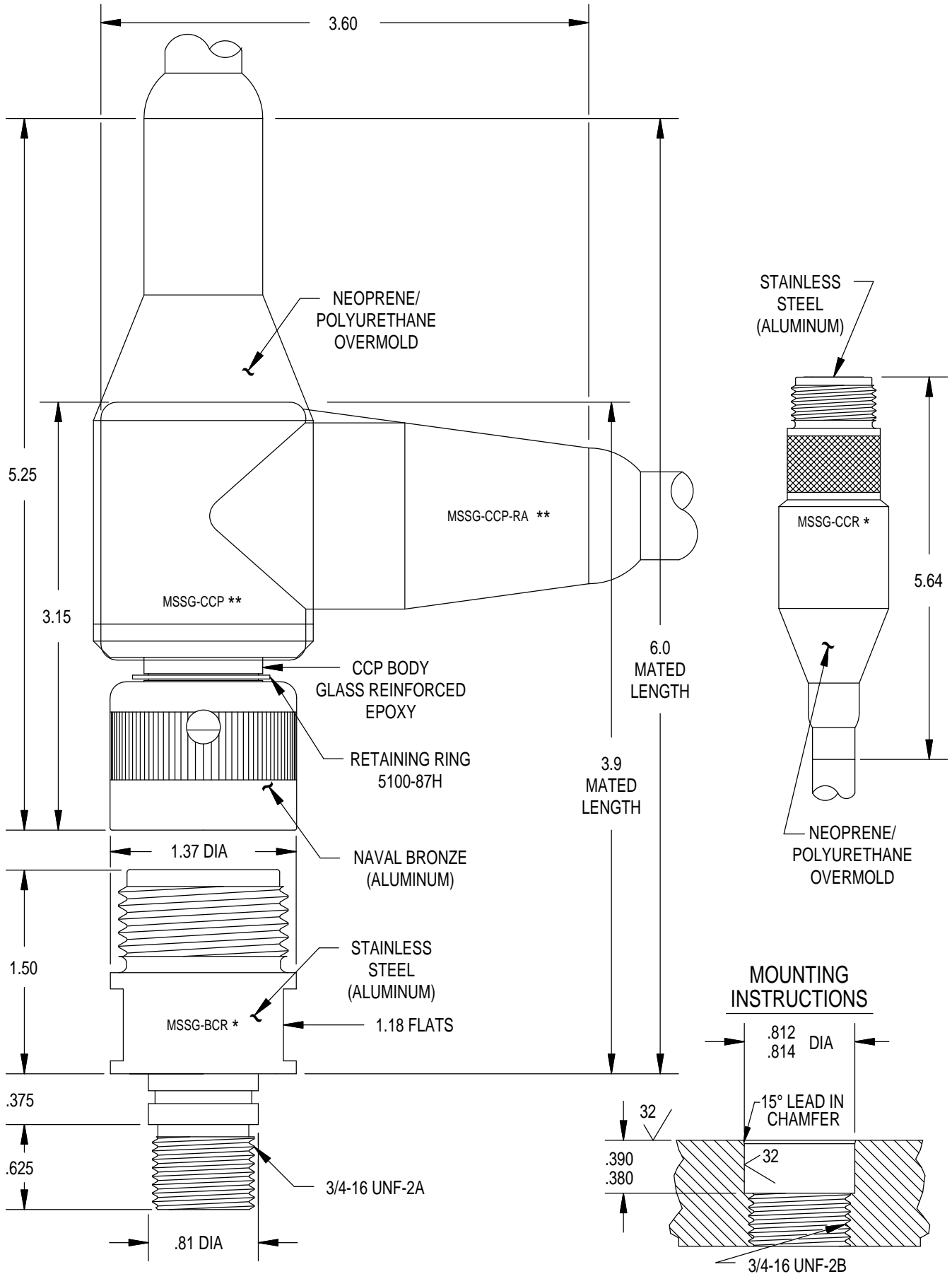

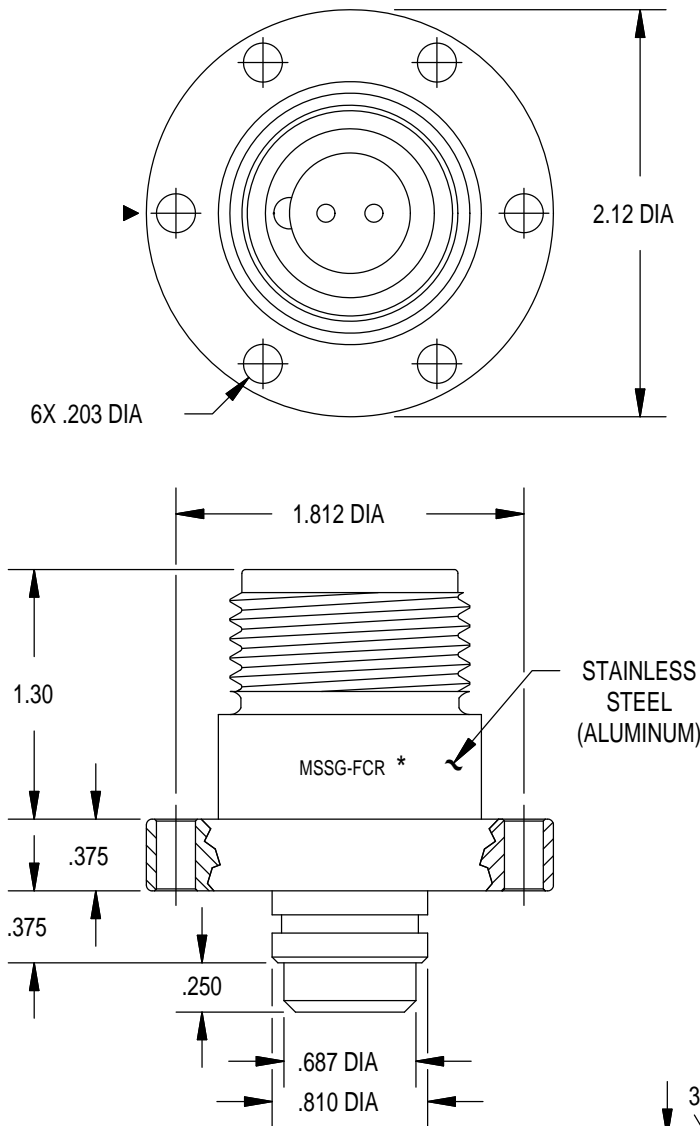

**CONTACT
CONFIGURATION**
(BCR FACE VIEWS)

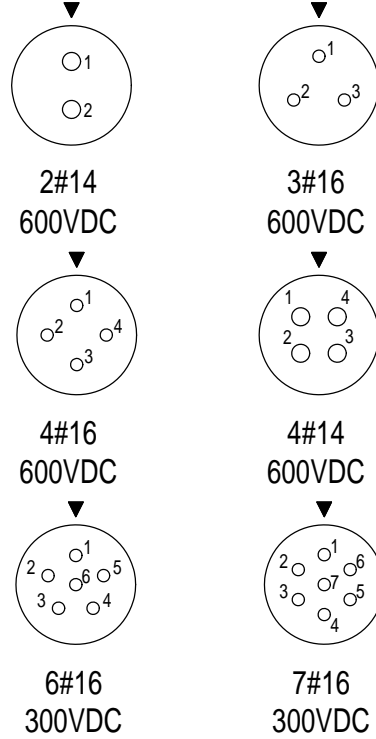

MOUNTING INSTRUCTIONS

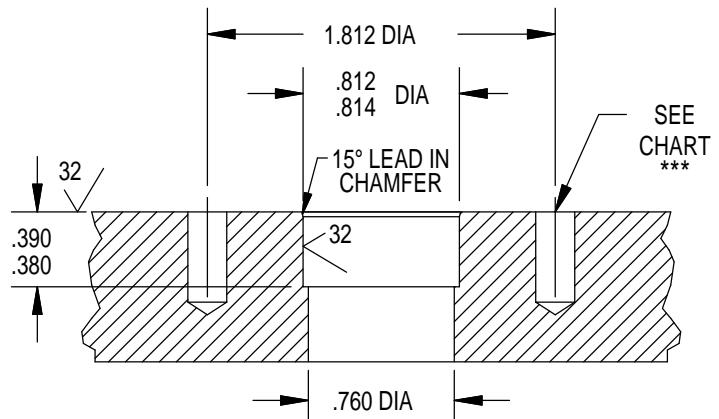

MOUNTING TORQUE FOR MSSG, MSAG-BCR	not to exceed 200 in lbs	MATED PRESSURE RATING (psi)	20,000
DUMMY PLUG FOR MSSG-BCR/FCR/CCR	MSSG-SCP	DUMMY PLUG FOR MSSG-CCP	MSSG-SCR
DUMMY PLUG FOR MSAG-BCR/FCR/CCR	MSAG-SCP	DUMMY PLUG FOR MSAG-CCP	MSAG-SCR

NOTE: Delrin protective caps available upon request.
 * See Technical Bulletin 45 71 for internal assembly and hardware specifications.
 ** See Technical Bulletin 45 72 for internal assembly and hardware specifications.
 *** Blind tapped hole not to penetrate bulkhead, minimum full thread depth 2 times bolt diameter.

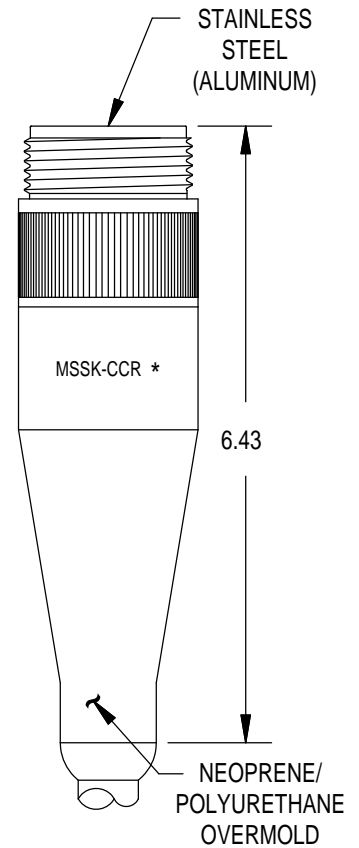
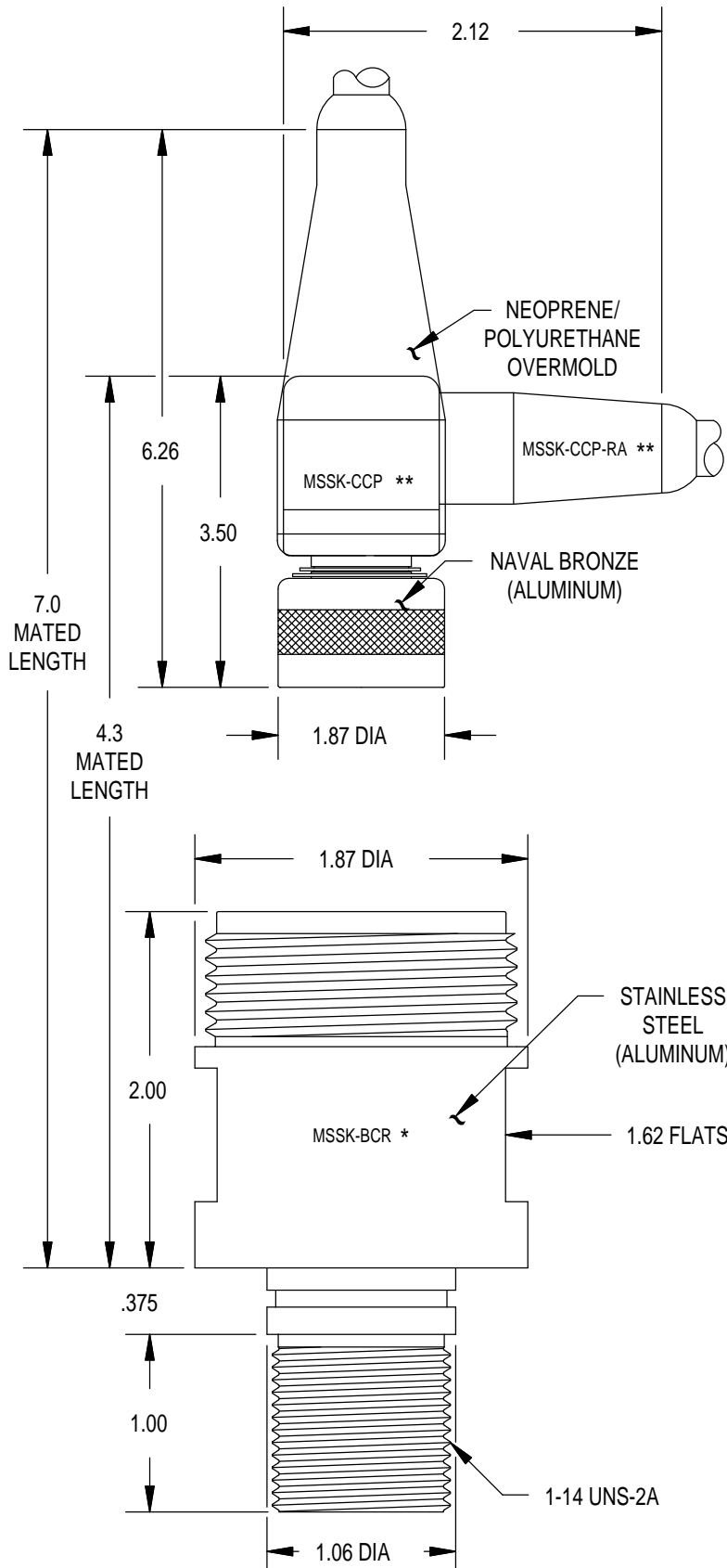

MOUNTING INSTRUCTIONS

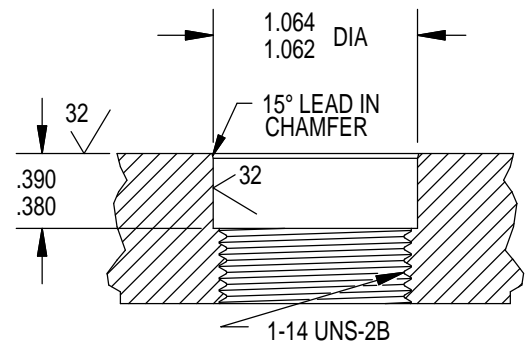

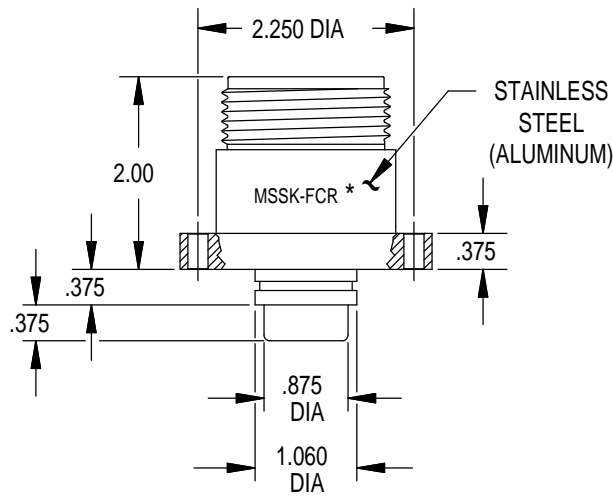
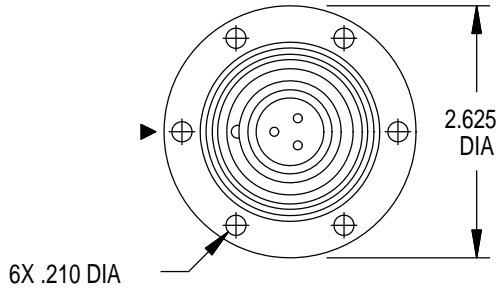

MOUNTING INSTRUCTIONS

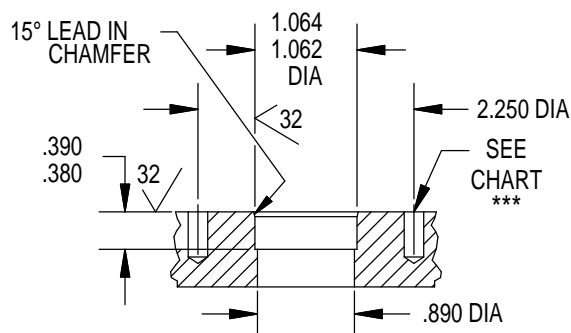

CONTACT CONFIGURATION (BCR FACE VIEWS)

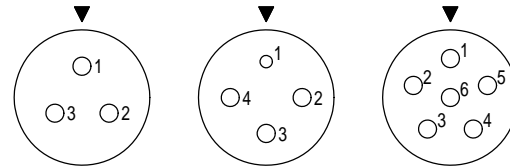

3#14
600VDC
1#16
3#14
600VDC
6#14
600VDC

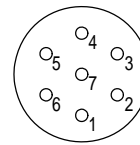

7#16
600VDC

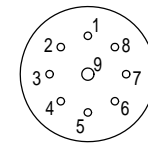

1#16
8#20
600VDC

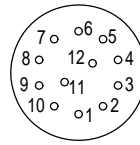

12#20
600VDC

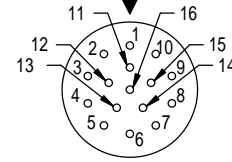

16#20
600VDC

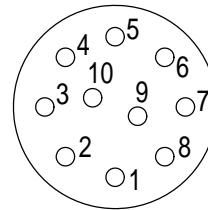

10#16 IE
600VDC

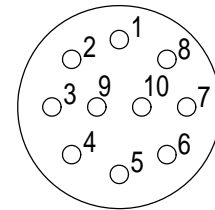

10#16 NAVY
600VDC

NOTE: Please specify Navy or IE pin configuration when ordering.

MOUNTING TORQUE FOR MSSK, MSAK-BCR	not to exceed 200 in lbs	MATED PRESSURE RATING (psi)	20,000
DUMMY PLUG FOR MSSK-BCR/FCR/CCR	MSSK-SCP	DUMMY PLUG FOR MSSK-CCP	MSSK-SCR
DUMMY PLUG FOR MSAK-BCR/FCR/CCR	MSAK-SCP	DUMMY PLUG FOR MSAK-CCP	MSAK-SCR

NOTE: Delrin protective caps available upon request.

* See Technical Bulletin 45 71 for internal assembly and hardware specifications.

** See Technical Bulletin 45 72 for internal assembly and hardware specifications.

*** Blind tapped hole not to penetrate bulkhead, minimum full thread depth 2 times bolt diameter.

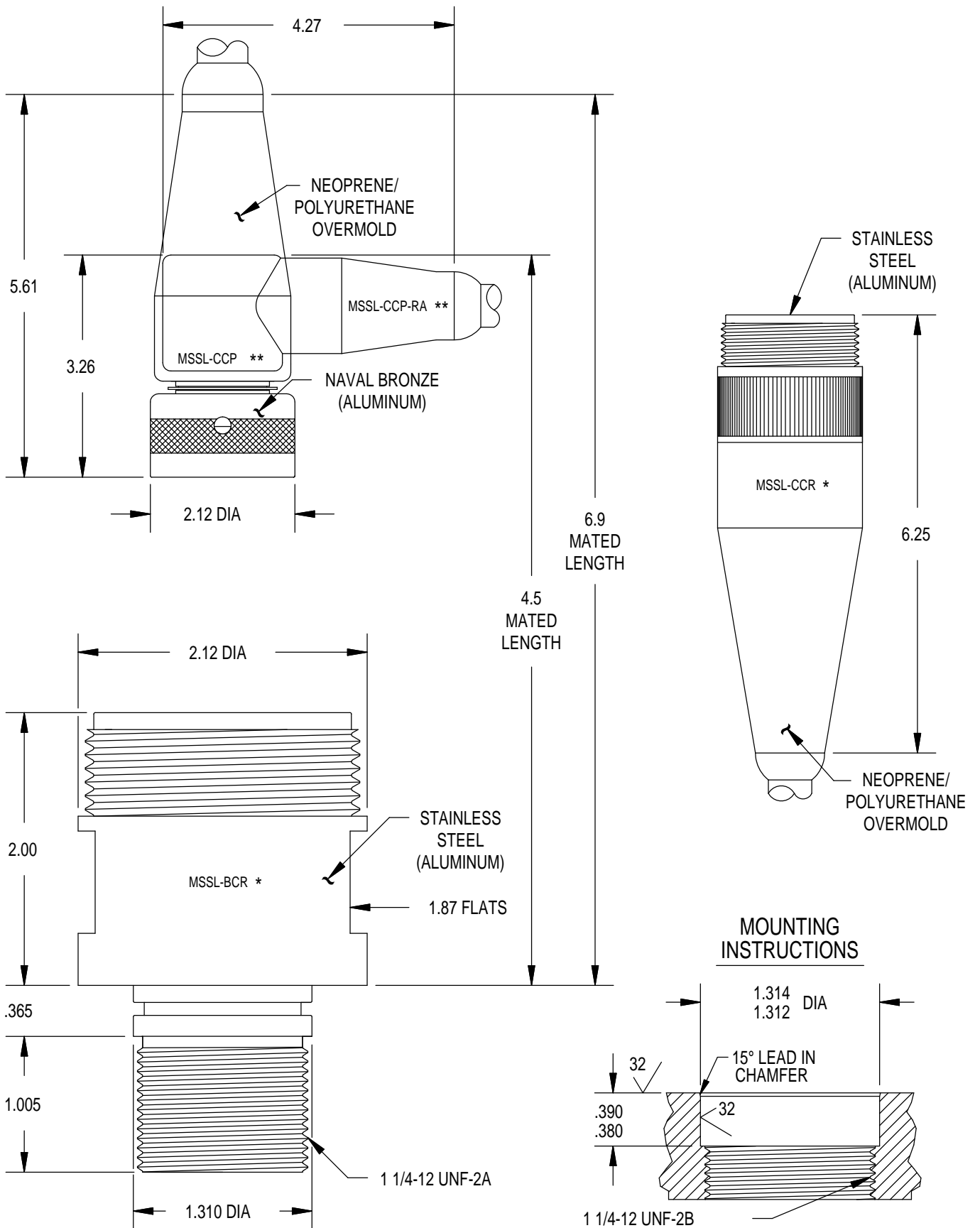

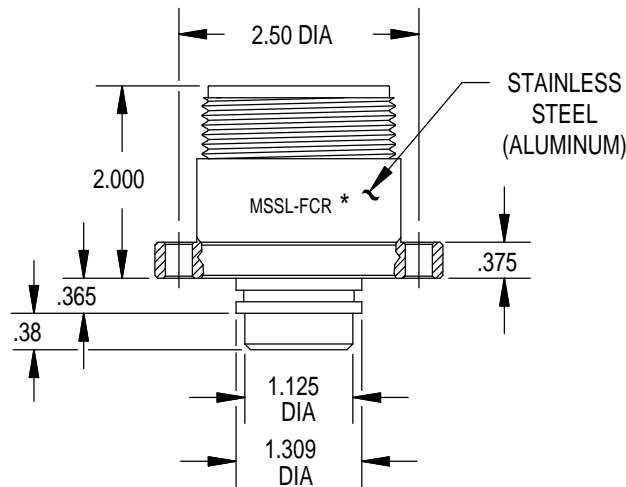
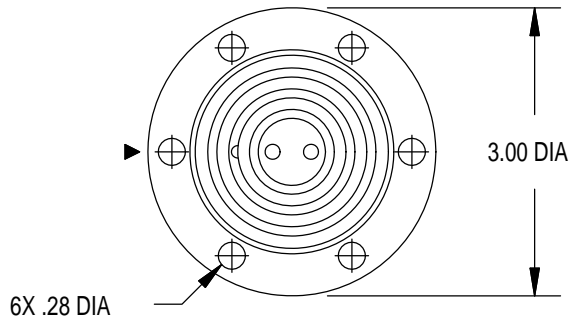

MOUNTING INSTRUCTIONS

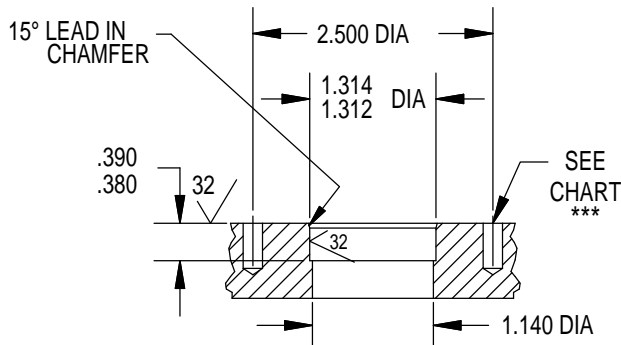

MOUNTING TORQUE FOR MSSL, MSAL-BCR	not to exceed 200 in lbs	MATED PRESSURE RATING (psi)	20,000
DUMMY PLUG FOR MSSL-BCR/FCR/CCR	MSSL-SCP	DUMMY PLUG FOR MSSL-CCP	MSSL-SCR
DUMMY PLUG FOR MSAL-BCR/FCR/CCR	MSAL-SCP	DUMMY PLUG FOR MSAL-CCP	MSAL-SCR

NOTE: Delrin protective caps available upon request.
 * See Technical Bulletin 45 71 for internal assembly and hardware specifications.
 ** See Technical Bulletin 45 72 for internal assembly and hardware specifications.
 *** Blind tapped hole not to penetrate bulkhead, minimum full thread depth 2 times bolt diameter.

**CONTACT
CONFIGURATION**
(BCR FACE VIEWS)

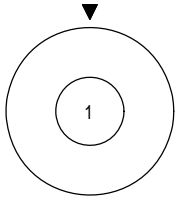

1#1/0
1000VDC

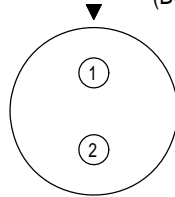

2#8
1000VDC

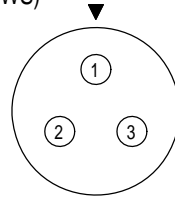

3#8
1000VDC

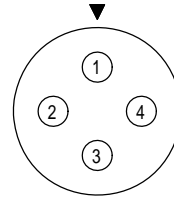

4#8 *
1000VDC

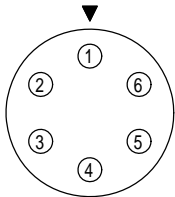

6#10
1000VDC

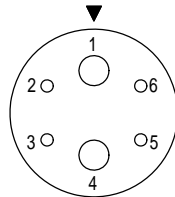

2#8
4#16
1000VDC

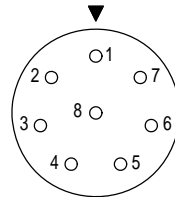

8#16
600VDC

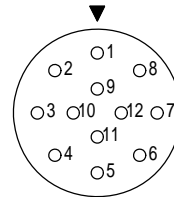

12#16
600VDC

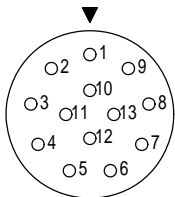

13#16
600VDC

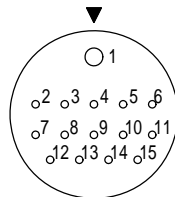

1#16
14#20
600VDC

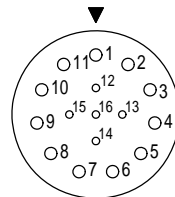

5#20
11#16
600VDC

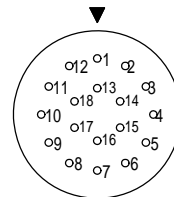

18#20
600VDC

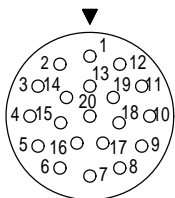

20#16
600VDC

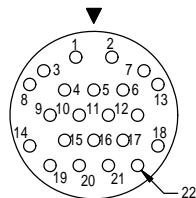

22#16
600VDC

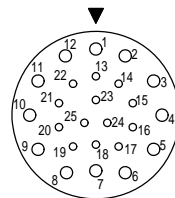

12#16
13#20
600VDC

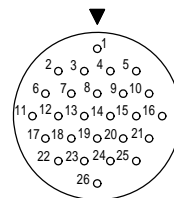

26#20
600VDC

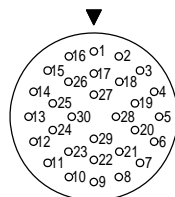

30#20
600VDC

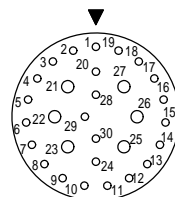

6#16
24#20
600VDC

* Also available in high voltage.
(3000VDC)

THIS PAGE INTENTIONALLY LEFT BLANK

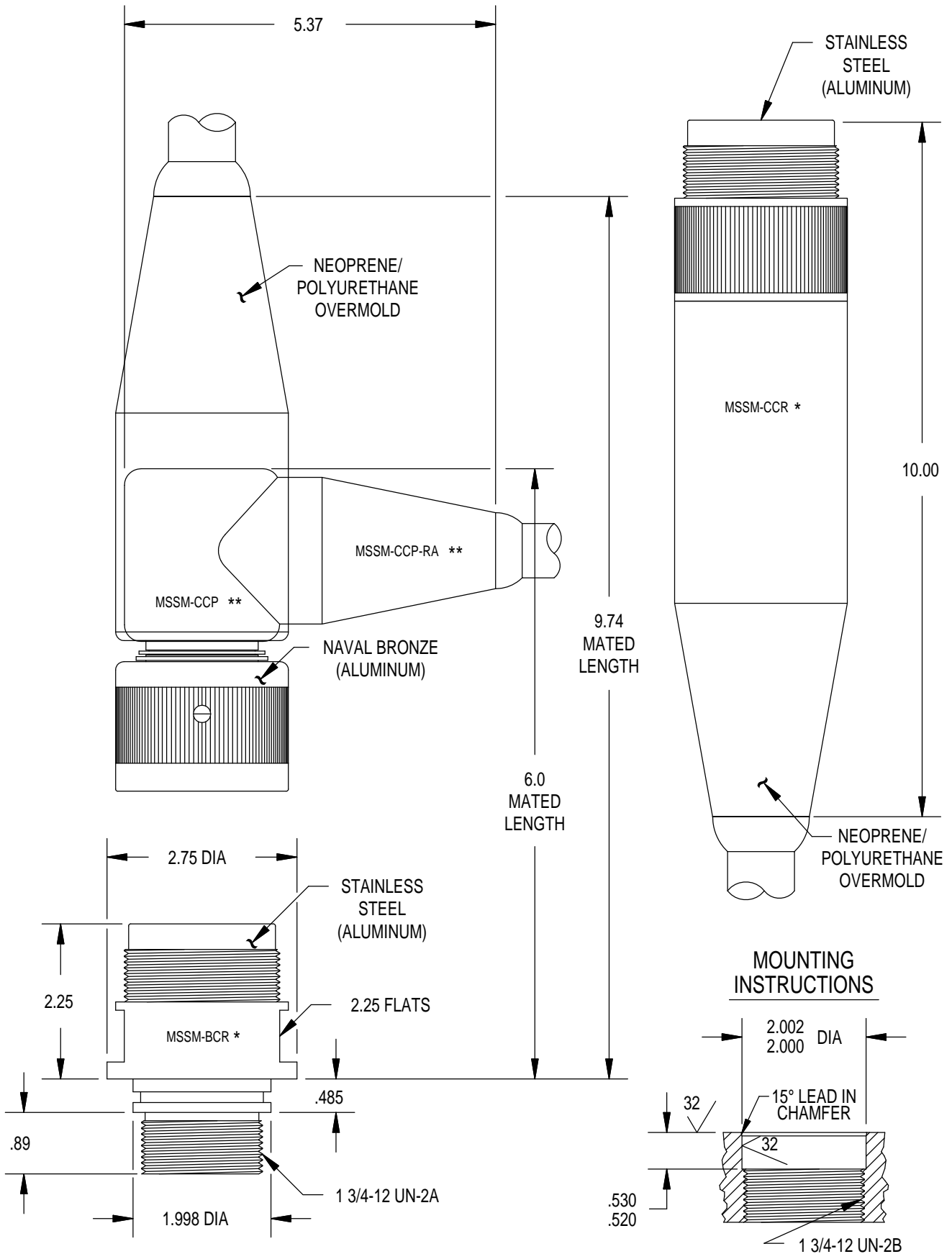

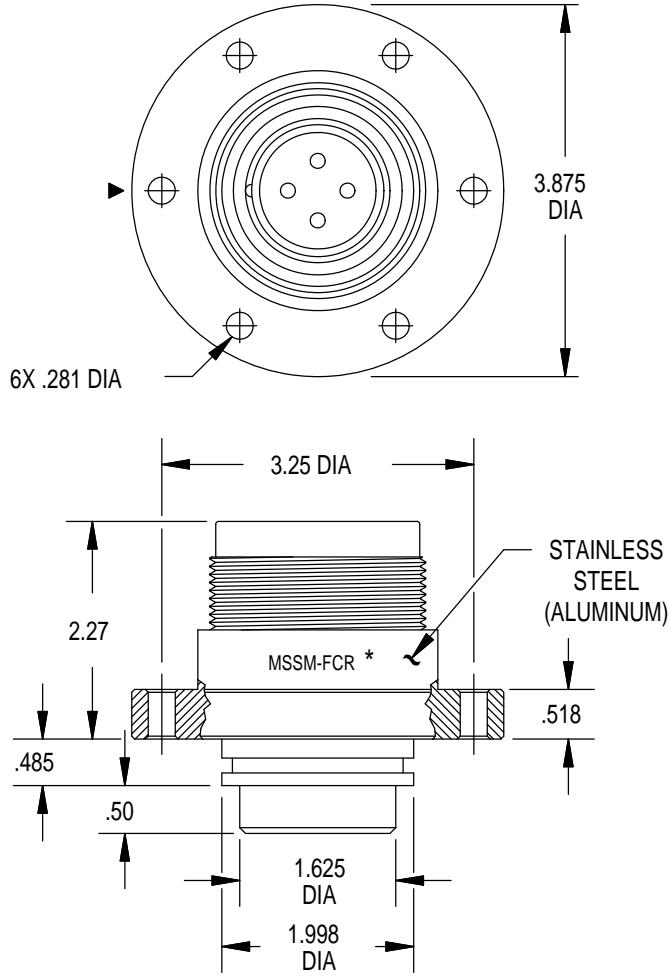

MOUNTING INSTRUCTIONS

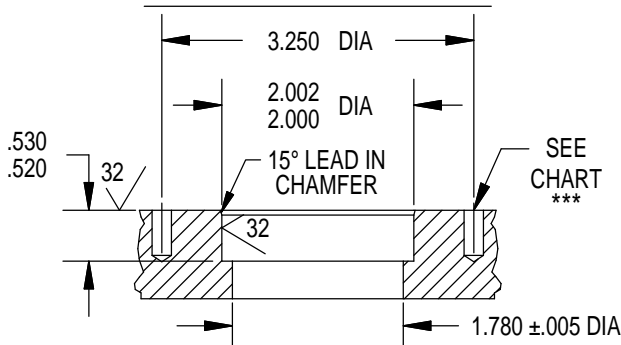

MOUNTING TORQUE FOR MSSM, MSAM-BCR	not to exceed 200 in lbs	MATED PRESSURE RATING (psi)	20,000
DUMMY PLUG FOR MSSM-BCR/FCR/CCR	MSSM-SCP	DUMMY PLUG FOR MSSM-CCP	MSSM-SCR
DUMMY PLUG FOR MSAM-BCR/FCR/CCR	MSAM-SCP	DUMMY PLUG FOR MSAM-CCP	MSAM-SCR

NOTE: Delrin protective caps available upon request.

* See Technical Bulletin 45 71 for internal assembly and hardware specifications.

** See Technical Bulletin 45 72 for internal assembly and hardware specifications.

*** Blind tapped hole not to penetrate bulkhead, minimum full thread depth 2 times bolt diameter.

CONTACT
CONFIGURATION
(BCR FACE VIEWS)

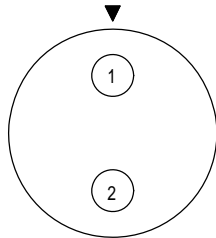

2#6 *
1500VDC

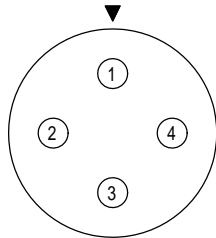

4#8 *
1500VDC

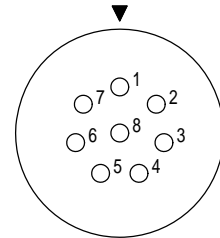

8#14
600VDC

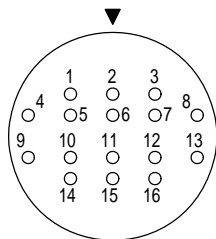

16#16
600VDC

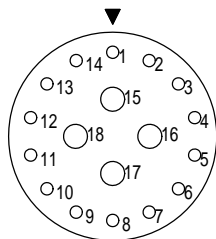

4#10
14#16
600VDC

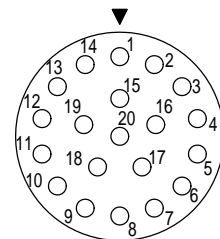

20#14
600VDC

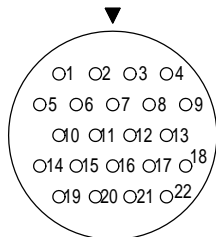

22#16
600VDC

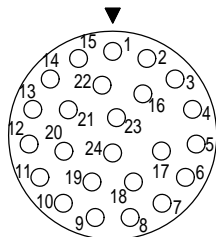

24#14
600VDC

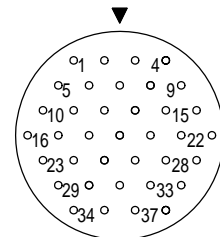

37#20
600VDC

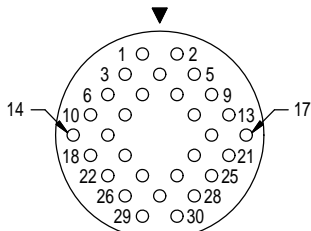

30#16
600VDC

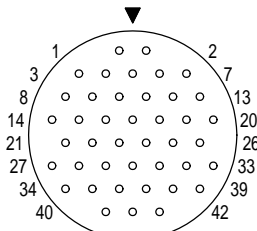

42#20
600VDC

* Also available in high voltage.
(3000VDC)

THIS PAGE INTENTIONALLY LEFT BLANK

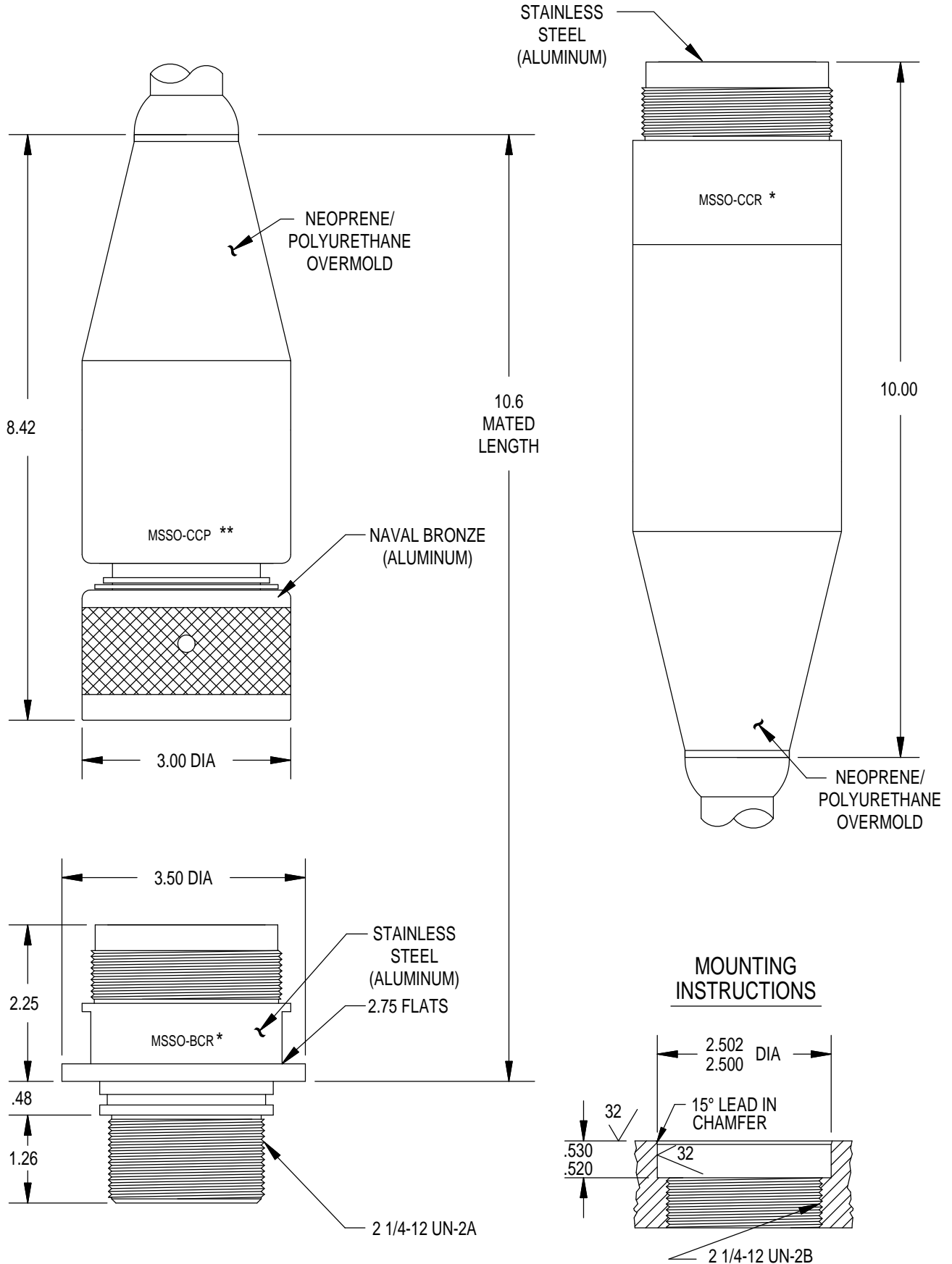

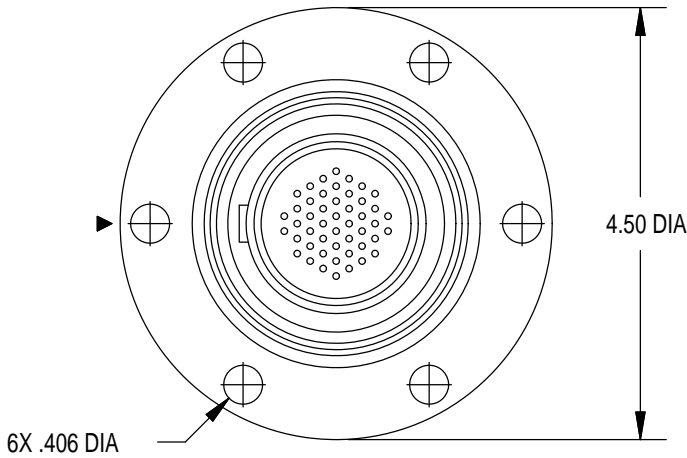

CONTACT
CONFIGURATION
(BCR FACE VIEWS)

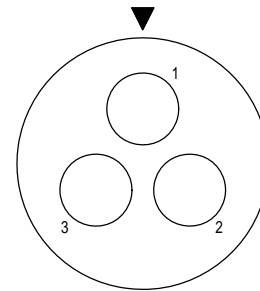

3#4
600VDC

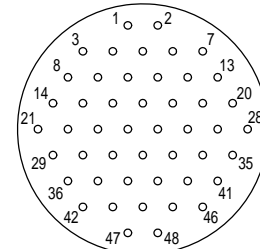

48#20
600VDC

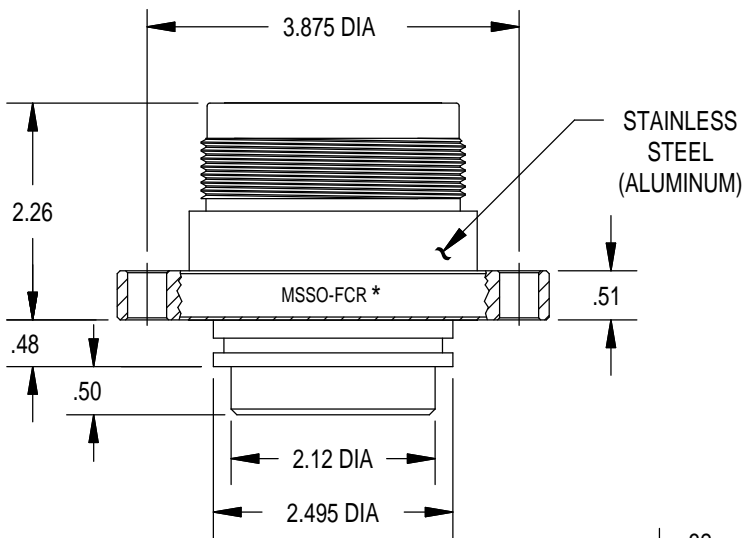

MOUNTING INSTRUCTIONS

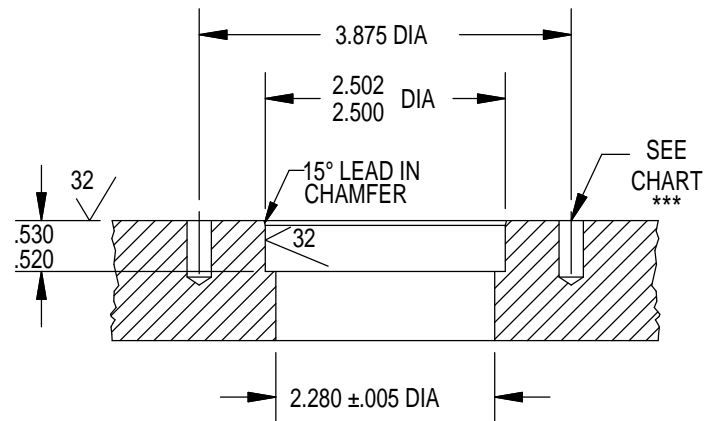

MOUNTING TORQUE FOR MSSO, MSAO-BCR	not to exceed 200 in lbs	MATED PRESSURE RATING (psi)	20,000
DUMMY PLUG FOR MSSO-BCR/FCR/CCR	MSSO-SCP	DUMMY PLUG FOR MSSO-CCP	MSSO-SCR
DUMMY PLUG FOR MSAO-BCR/FCR/CCR	MSAO-SCP	DUMMY PLUG FOR MSAO-CCP	MSAO-SCR

NOTE: Delrin protective caps available upon request.

* See Technical Bulletin 45 71 for internal assembly and hardware specifications.

** See Technical Bulletin 45 72 for internal assembly and hardware specifications.

*** Blind tapped hole not to penetrate bulkhead, minimum full thread depth 2 times bolt diameter.

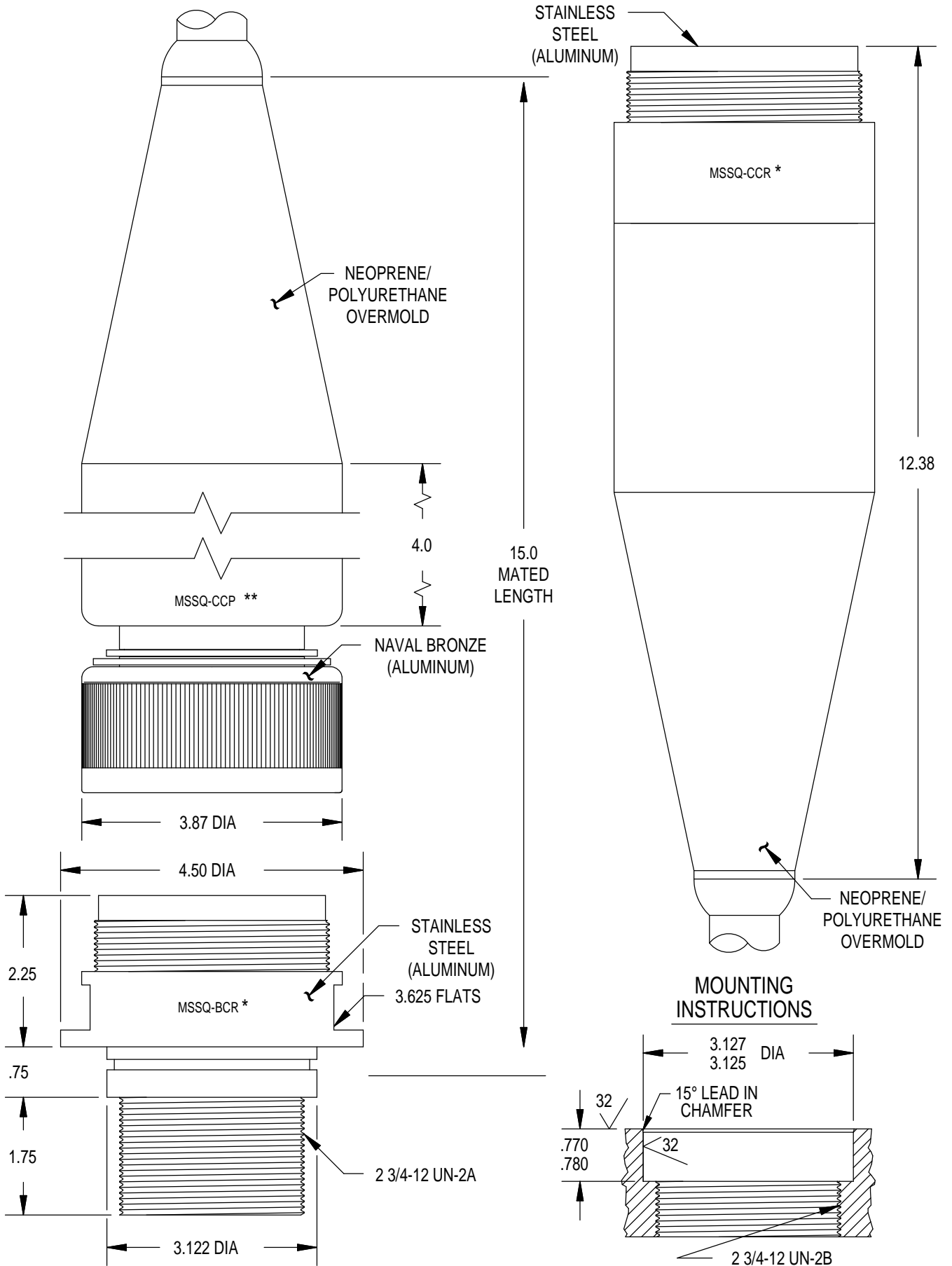

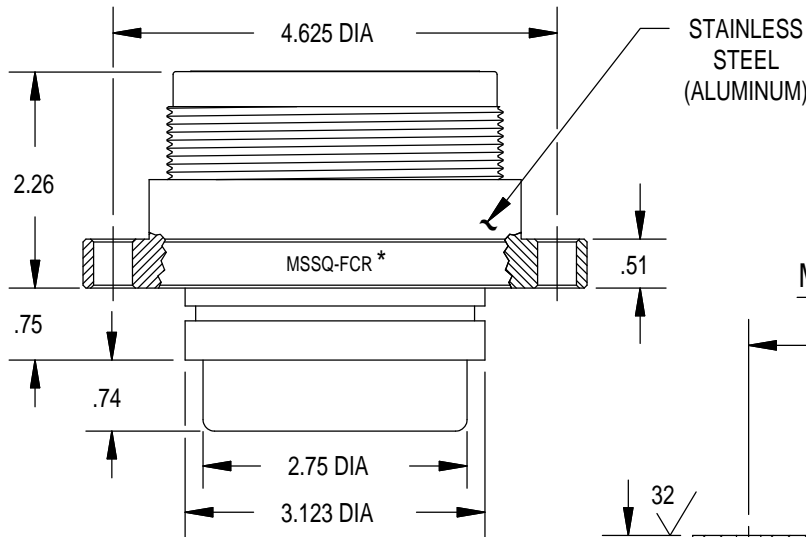
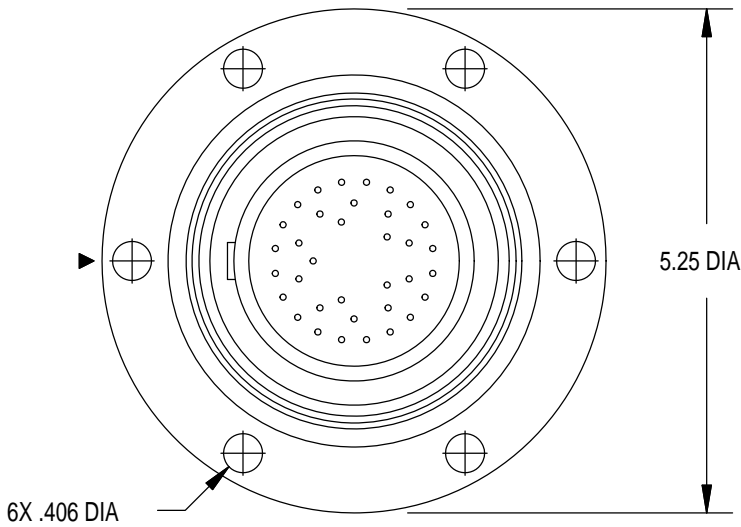

MOUNTING INSTRUCTIONS

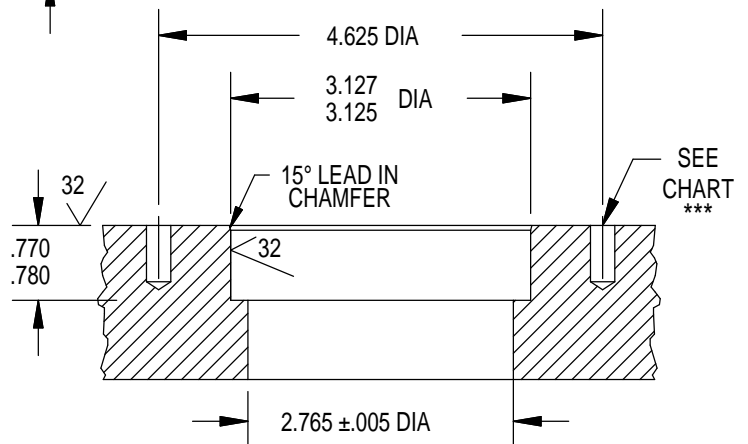

MOUNTING TORQUE FOR MSSQ, MSAQ-BCR	not to exceed 200 in lbs	MATED PRESSURE RATING (psi)	20,000
DUMMY PLUG FOR MSSQ-BCR/FCR/CCR	MSSQ-SCP	DUMMY PLUG FOR MSSQ-CCP	MSSQ-SCR
DUMMY PLUG FOR MSAQ-BCR/FCR/CCR	MSAQ-SCP	DUMMY PLUG FOR MSAQ-CCP	MSAQ-SCR

NOTE: Delrin protective caps available upon request.

* See Technical Bulletin 45 71 for internal assembly and hardware specifications.

** See Technical Bulletin 45 72 for internal assembly and hardware specifications.

*** Blind tapped hole not to penetrate bulkhead, minimum full thread depth 2 times bolt diameter.

CONTACT
CONFIGURATION
(BCR FACE VIEWS)

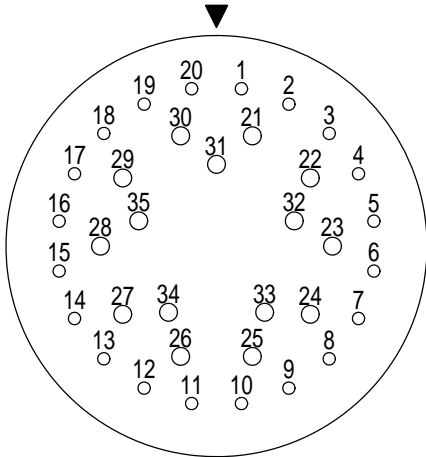

15#14
20#16
(High Voltage)
2000VDC

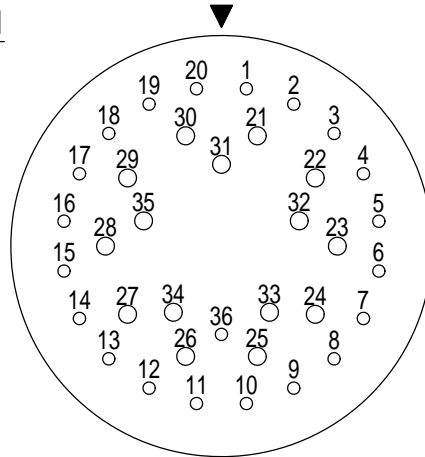

15#14
21#16
(High Voltage)
2000VDC

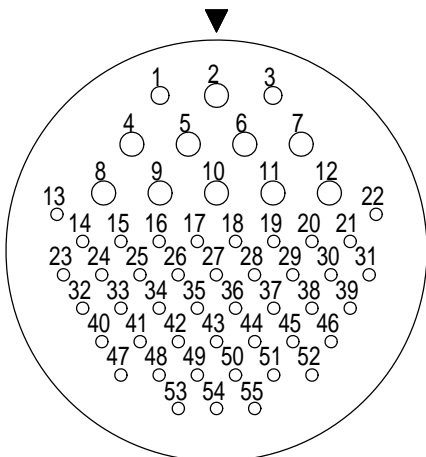

10#10
45#16
600VDC

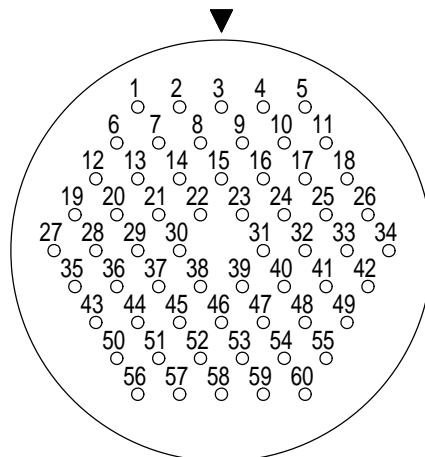

60#16
600VDC

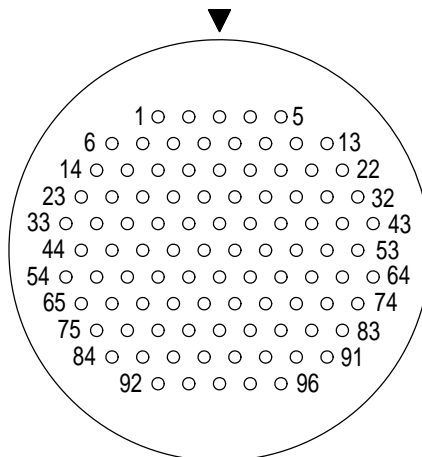

96#16
600VDC

THIS PAGE INTENTIONALLY LEFT BLANK

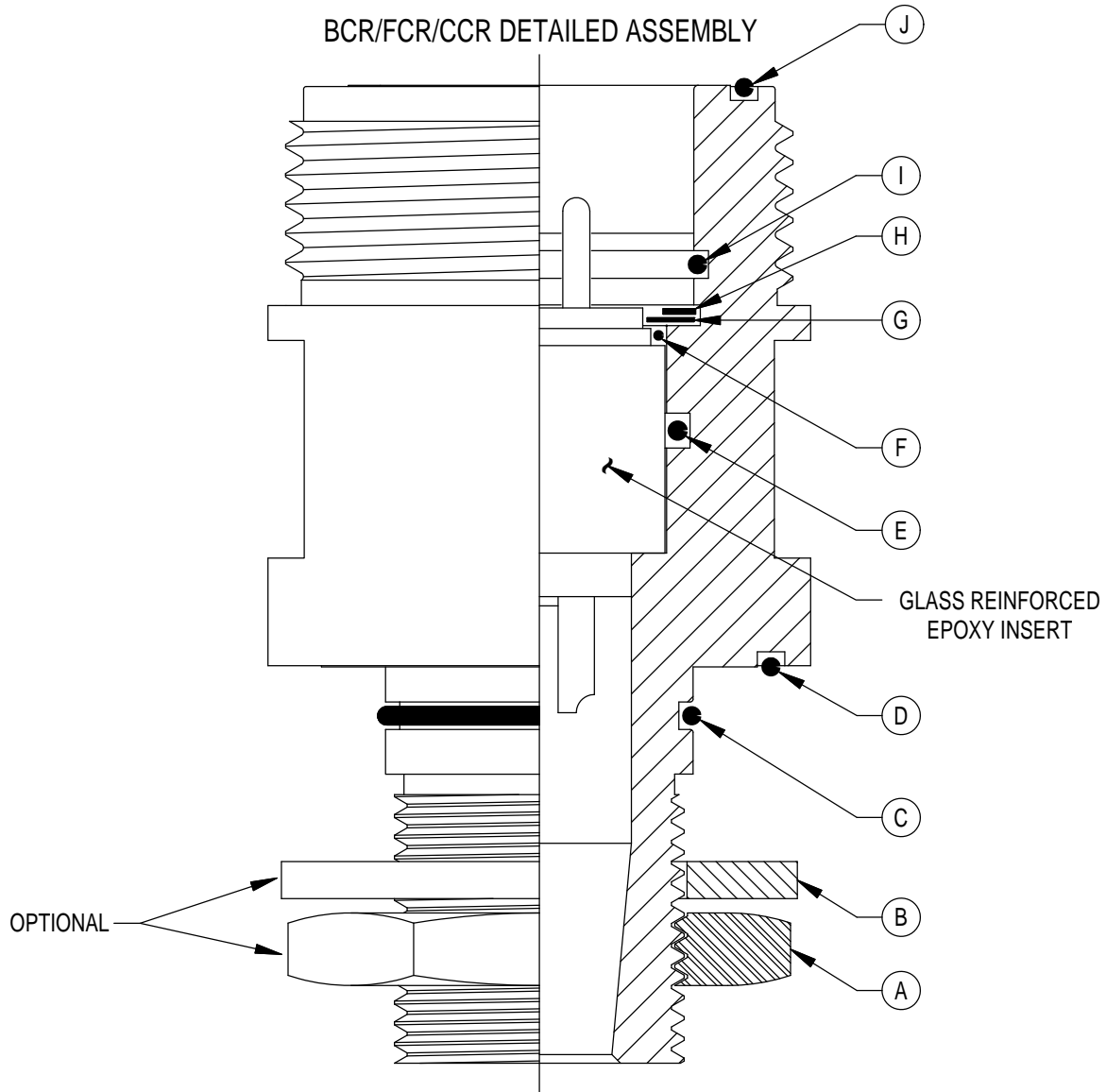

SCALE NONE

SHELL SIZE	G	K	L	M	O	Q
A BULKHEAD NUT *	35000 S 00	35000 S 01	35000 S 02	35000 S 03	35000 S 04	35000 S 06
B BULKHEAD WASHER *	35500 S 00	35500 S 01	35500 S 02	35500 S 03	35500 S 04	35500 S 06
C O-RING **	2-017	2-021	2-122	2-224	2-228	2-233
D O-RING **	2-023	2-029	2-131	2-142	2-234	2-241 ***
E O-RING	2-016	2-118	2-122	2-126	2-225	2-230
F O-RING	NONE	2-018	2-022	2-123	2-131	2-141
G INTERNAL WASHER	NONE	35000 S 21	35000 S 22	35000 S 23	35000 S 24	35000 S 26
H SPIROLOX RING	UR-62	UR-106	UR-131	UR-150	UR-187	UR-250
I O-RING	2-016	2-023	2-027	2-128	2-225	2-230
J O-RING	2-020	2-027	5-320	2-132	2-140	2-151

NOTE: See Technical Bulletin 45 10 for J size detailed assembly.

* Not required with FCR or CCR assemblies.

** Not required with CCR assembly.

*** FCR uses 2-240.

CCP DETAILED ASSEMBLY

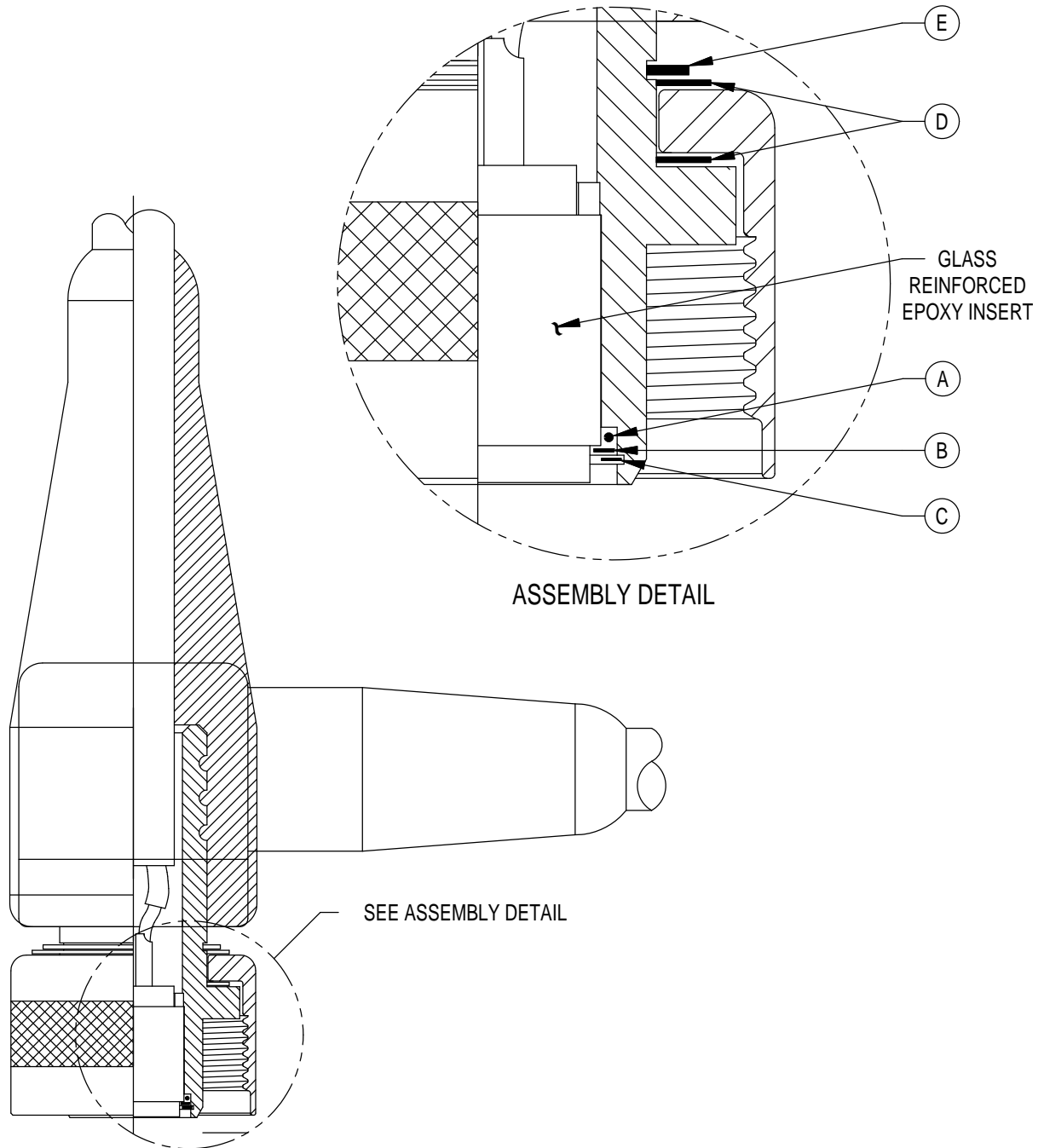

ASSEMBLY DETAIL

SEE ASSEMBLY DETAIL

SCALE NONE

SHELL SIZE	G	K	L	M	O	Q
A O-RING	NONE	2-017	2-021	2-024	2-127	2-137
B WASHER	NONE	35000 S 31	35000 S 32	35000 S 33	35000 S 34	35000 S 36
C SPIROLOX RING	NONE	UR-87	UR-112	UR-137	UR-162	UR-225
D DELRIN WASHER (2X)	NONE	35000 P 11	35000 P 12	35000 P 13	35000 P 14	35000 P 16
E RETAINING RING	5100-87	5100-112	5100-137	5100-162	5100-212	5100-275

NOTE: See Technical Bulletin 45 10 for J size detailed assembly.

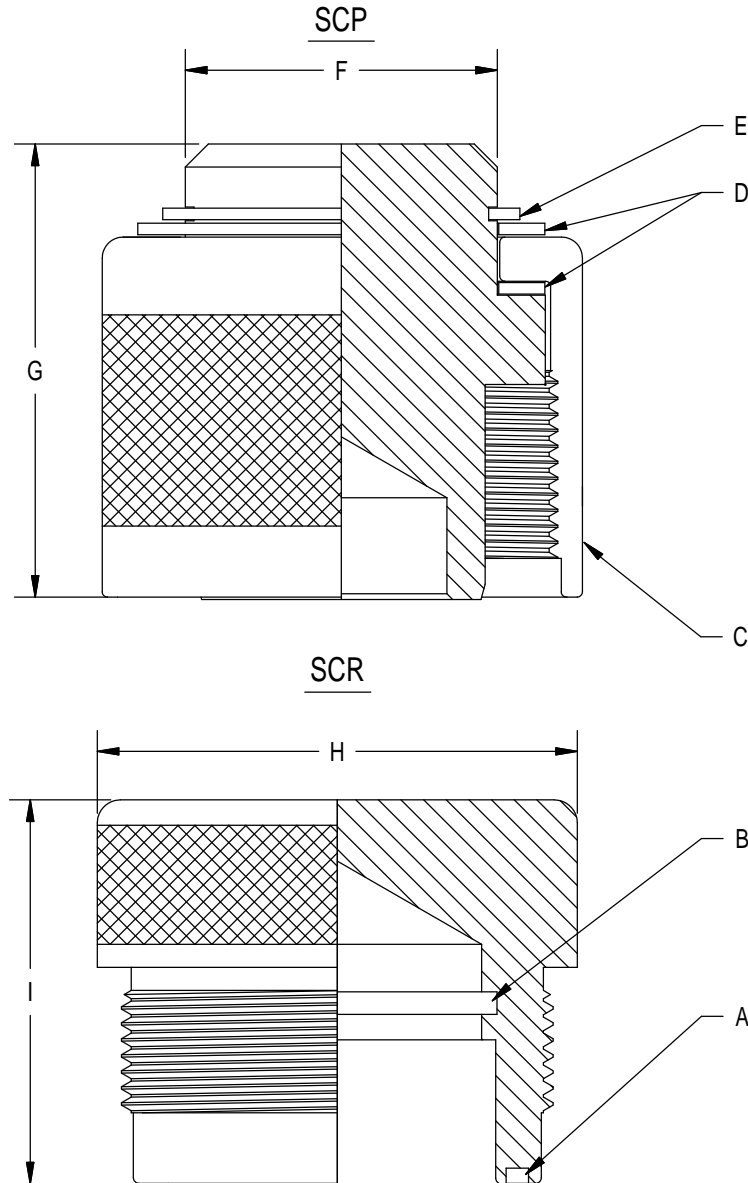

CONNECTOR SIZE	MSK	MSL	MSM	MSO	MSQ
A O-RING	2-027	5-320	2-132	2-140	2-151
B O-RING	2-023	2-027	2-128	2-225	2-230
C ENGAGING NUT	607406	607507	607606	607706	607917
D DELRIN WASHER (2X)	35000 P11	35000 P12	35000 P13	35000 P14	35000 P16
E RETAINING RING	5100-112	5100-137	5100-162	5100-212	5100-275
F DIA	1.11	1.38	1.62	2.12	2.75
G	1.56	1.56	2.37	2.37	2.37
H DIA	1.87	2.12	2.50	3.00	3.87
I	1.50	1.50	2.00	2.00	2.12
MATED PRESSURE RATING (psi)	20,000	20,000	20,000	20,000	20,000

SCALE NONE

DESCRIPTION AND
MATERIAL

- 316 stainless steel passivated per QQ-P-35 Type VI with naval bronze engaging nut.
- Optional material is (MSA) 6061-T6 Aluminum, hard anodized per MIL-A-8625, Type III, Class 2. (AVAILABLE IN STRAIGHT CONFIGURATION ONLY).
- Available in sizes: K, L, M & Q.
 - K - 1/2" O.D. Tube (Maximum)
 - L - 3/4" O.D. Tube (Maximum)
 - M - 1" O.D. Tube (Maximum)
 - Q - 1-1/4" O.D. Tube (Maximum)Customer to specify tube size at time of order.
- Up to 5,000 VDC.
- To 7,500 PSI in Mated Condition.

- Insert is glass reinforced epoxy with brass contacts.
- Contacts gold plated per MIL-G-45204.

MATING

- PBOF Series mates with Metal Shell BCR, FCR, and CCR.

USES

- Heavy duty applications.
- Hazardous, rugged environments.
- Power transmission.
- Signal telemetry.
- Commonly used on ROV's and large transducers.

PBOF PART NUMBER GUIDE

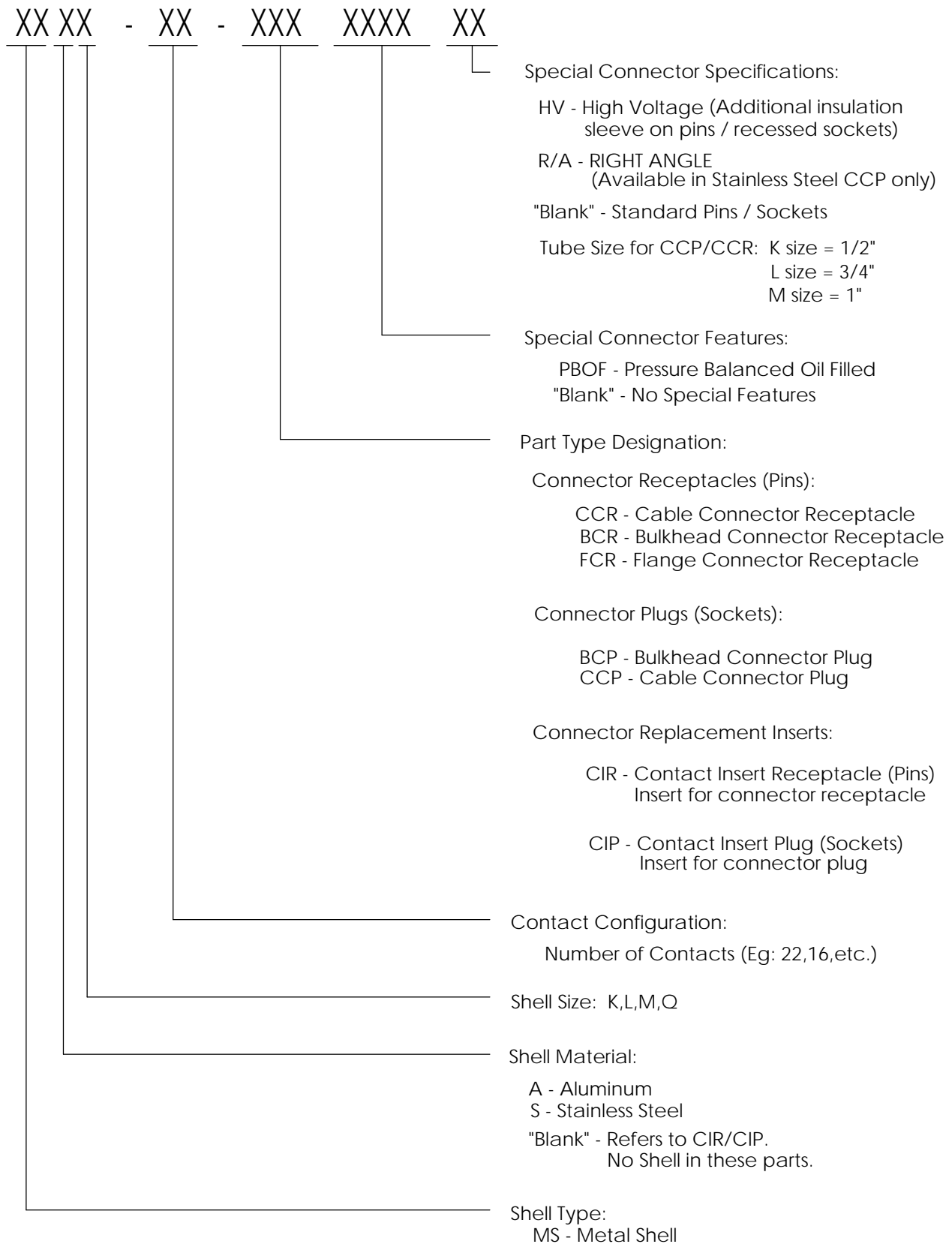

BULKHEAD CONNECTOR RECEPTACLE

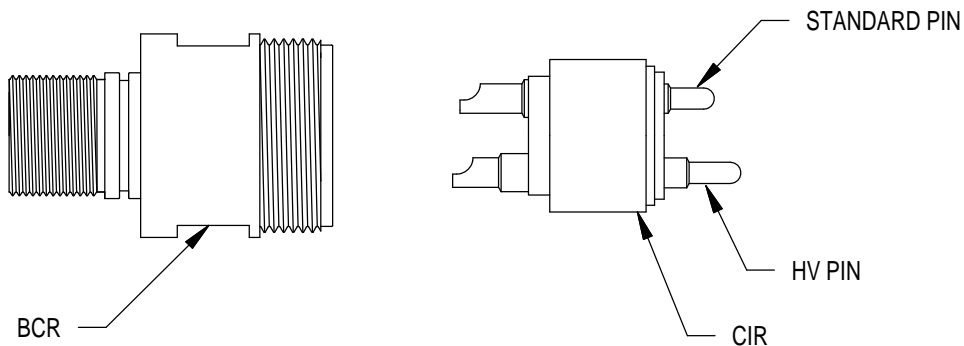

MSSL-*-BCR PBOF HV

DESCRIPTION:

SHELL TYPE: MS - METAL SHELL
 SHELL MATERIAL: S - STAINLESS STEEL
 SHELL SIZE: L
 CONTACT CONFIGURATION: *
 PART TYPE: BCR - BULKHEAD CONNECTOR RECEPTACLE
 SPECIAL FEATURES: PBOF - PRESSURE BALANCED OIL FILLED
 SPECIAL CONTACT SPECS: HV - HIGH VOLTAGE

CABLE CONNECTOR PLUG

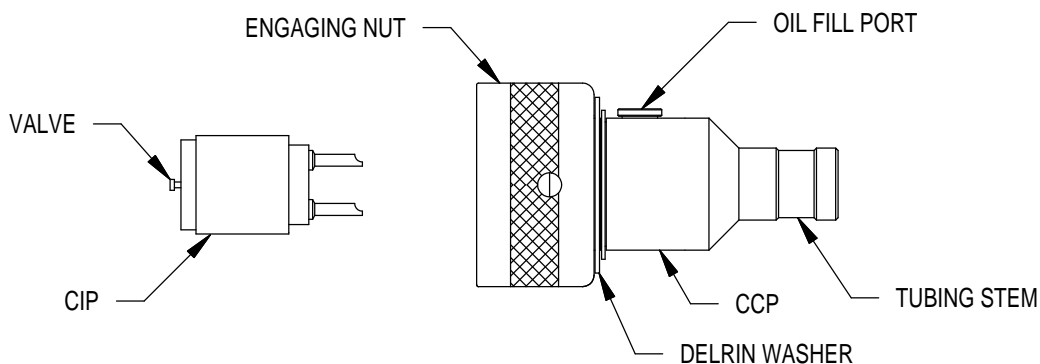

MSAL-*-CCP PBOF w/ 3/4" Tube

DESCRIPTION:

SHELL TYPE: MS - METAL SHELL
 SHELL MATERIAL: A - ALUMINUM
 SHELL SIZE: L
 CONTACT CONFIGURATION: *
 PART TYPE: CCP - CABLE CONNECTOR PLUG
 SPECIAL FEATURES: PBOF - PRESSURE BALANCED OIL FILLED
 3/4" TUBE - ID OF TUBING TO BE USED
 (3/4" STANDARD FOR OCEANEERING)

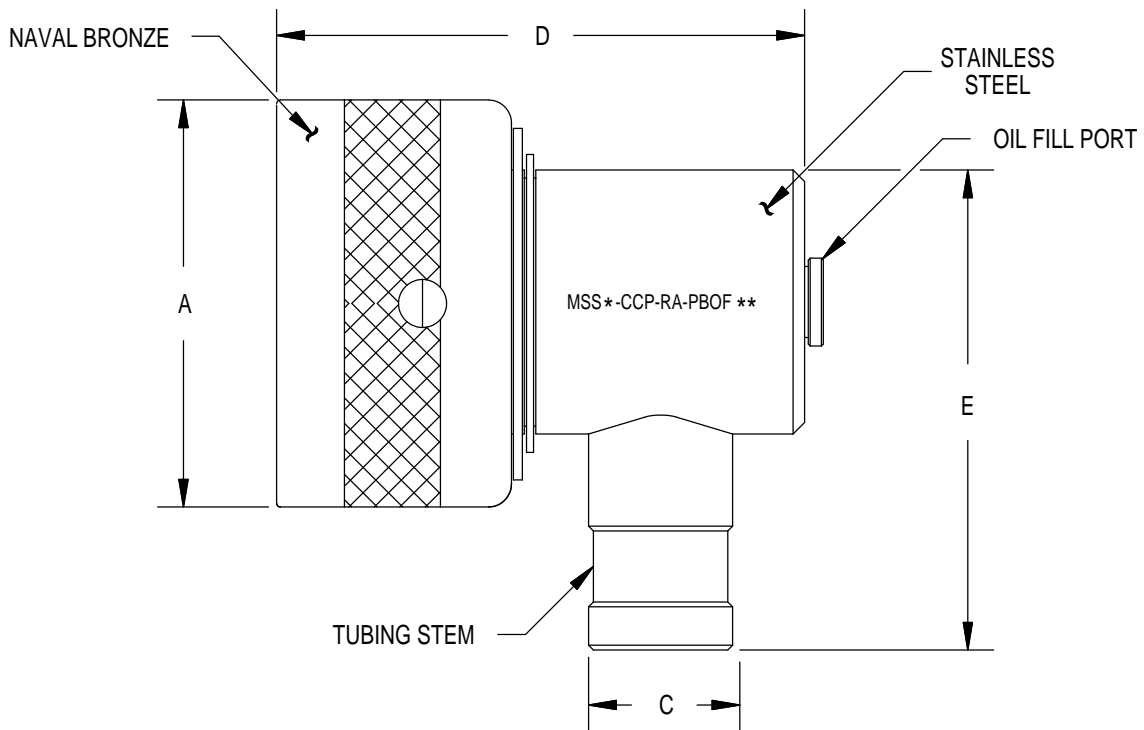
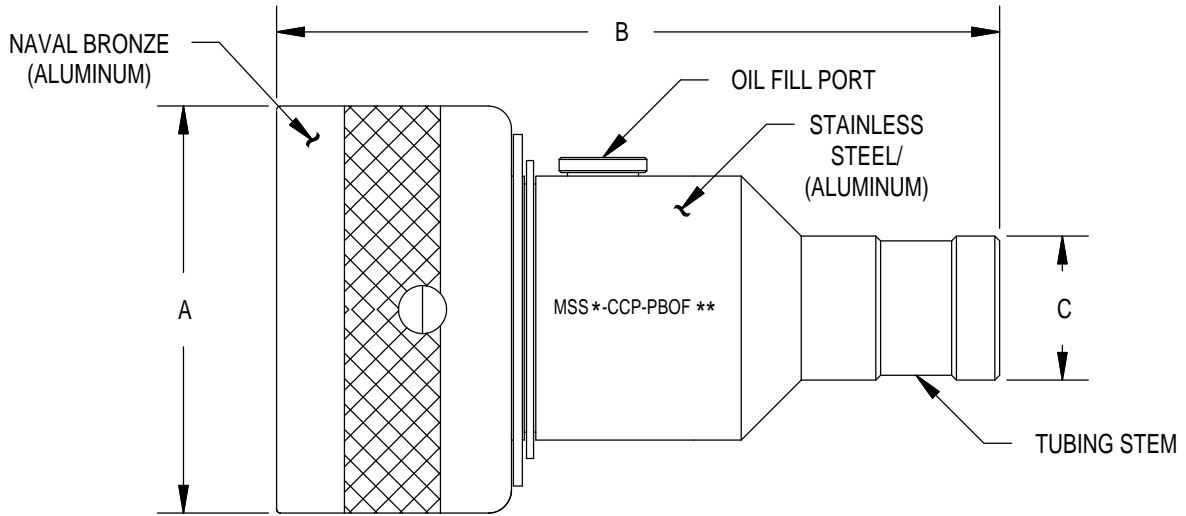

SHOWN SHELL SIZE 'L'

SHELL SIZE	A	B	C	D	E
K	1.87	3.50	1/2" MAX	2.60	2.12
L	2.12	3.75	3/4" MAX	2.75	2.50
M	2.50	5.00	1" MAX	3.70	3.00
Q	3.87	7.00	1-1/4" MAX	4.00	4.12

NOTE: Specify O.D. of tube at time of order.

* Specify shell size.

** See Technical Bulletin 45 72 for internal assembly and hardware specifications.

K SIZE CONTACT
CONFIGURATION
(BCR FACE VIEWS)

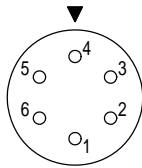

6#16
1500VDC

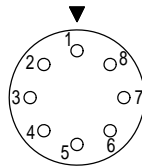

8#16
1000VDC

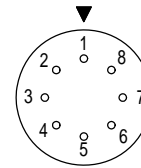

8#20
600VDC

L SIZE CONTACT
CONFIGURATION
(BCR FACE VIEW)

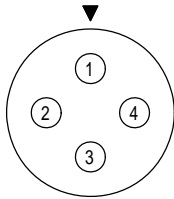

4#8
High Voltage
3000VDC

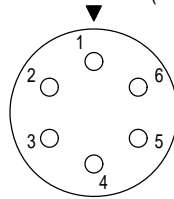

6#14
1000VDC

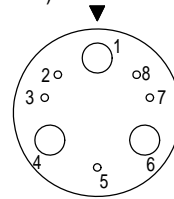

5#20
3#8
600VDC

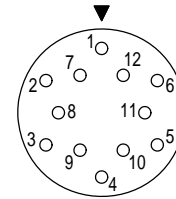

12#16
1000VDC

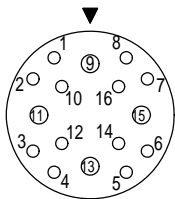

4#14
12#16
1000VDC

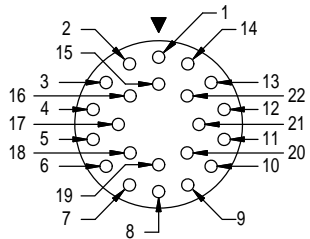

22#16
1000VDC

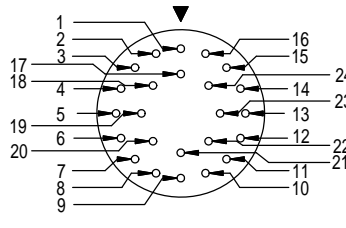

24#20
600VDC

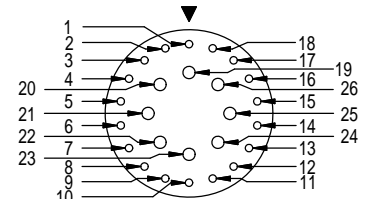

8#16
18#20
300VDC

M SIZE CONTACT
CONFIGURATION
(BCR FACE VIEWS)

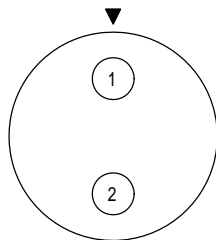

2#6
1000 VDC

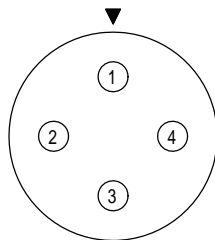

4#8 *
1000VDC

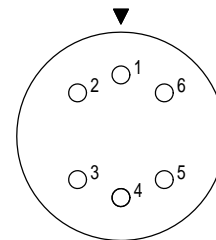

6#14
600VDC

* Also available in high voltage.
(3000 VDC)

M SIZE CONTACT
CONFIGURATION
(BCR FACE VIEWS)

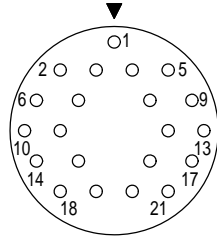

21#16
600VDC

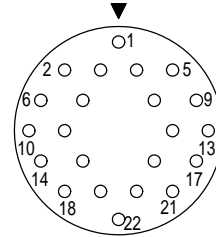

22#16
600VDC

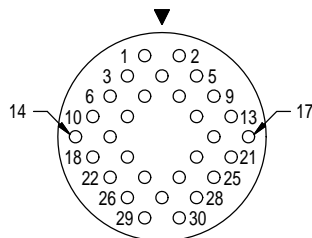

30#16
600VDC

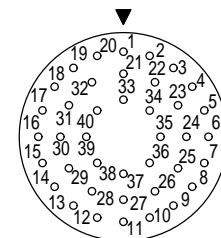

40#20
300VDC

Q SIZE CONTACT
CONFIGURATION
(BCR FACE VIEWS)

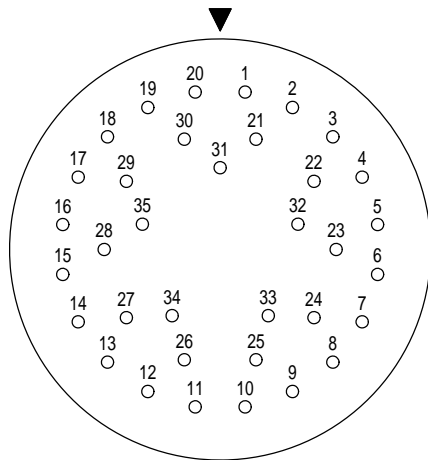

35#16
(High Voltage)
2000VDC

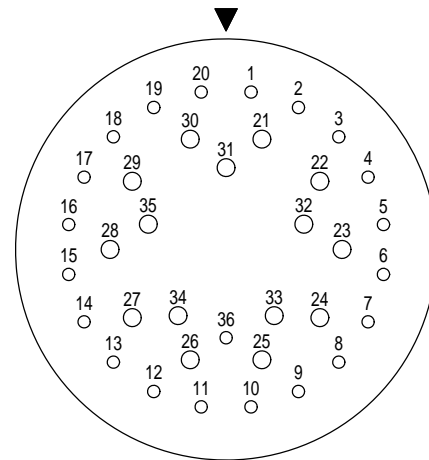

15#14
21#16
(High Voltage)
2000VDC

DESCRIPTION AND MATERIAL	<ul style="list-style-type: none"> • 316 stainless steel body passivated per QQ-P-35 Type VI. • Optional body is 6061-T6 aluminum, hard anodized per MIL-A-8625, Type III, Class 2. • Metal body waterblocked with glass reinforced epoxy insert and neoprene or polyurethane overmolded. • One to 30 conductors depending on gauge of conductors. • Up to 600 VDC. • Up to 10,000 PSI.
MATING	<ul style="list-style-type: none"> • This penetrator is threaded at one end with wire leads coming through the thread hole. The opposite end away from the penetrator can be terminated to a rubber, epoxy or metal shell connector. See applicable sections of catalogue for details.
CABLE	<ul style="list-style-type: none"> • Penetrators have 12" teflon leads, Type E per MIL 16878/4 18 AWG(except 1" PNA-26 and 30 contact versions). • The penetrator's amperage and voltage may be limited by amperage and voltage ratings of the cable to which the penetrator is molded.
USES	<ul style="list-style-type: none"> • Light to medium duty applications. • Hazardous environment. • Power transmission. • Signal telemetry. • Keeps mating and unmating manipulation away from bulkhead. • Allows greater flexibility in mating cable away from bulkhead. • Waterblocked insert keeps bulkhead from flooding if accidental cable damage occurs. • Very low right angle profile.
GUIDELINES	<ul style="list-style-type: none"> • May be threaded into bulkhead or fastened by use of a nut and washer. • All mounting surfaces require a 32 finish. • Keep o-ring grooves clean. • Avoid o-ring cuts and nicks. • Lubricate o-rings with Dow Corning #111 Valve Lubricant or equivalent. • Replace o-rings when re-using connectors. • Avoid contact with noxious solvents. • Elastomers can be seriously degraded if exposed to direct sunlight or high ozone levels for extended periods of time.

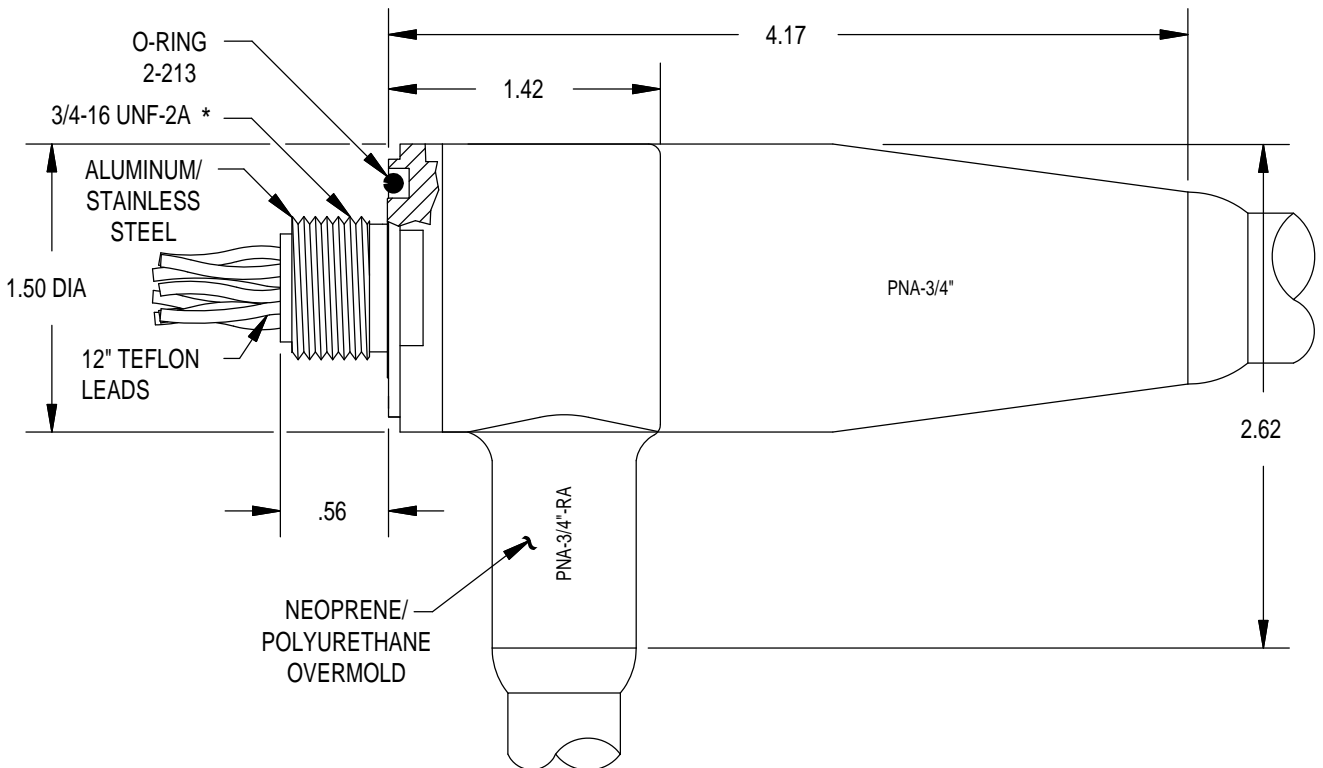
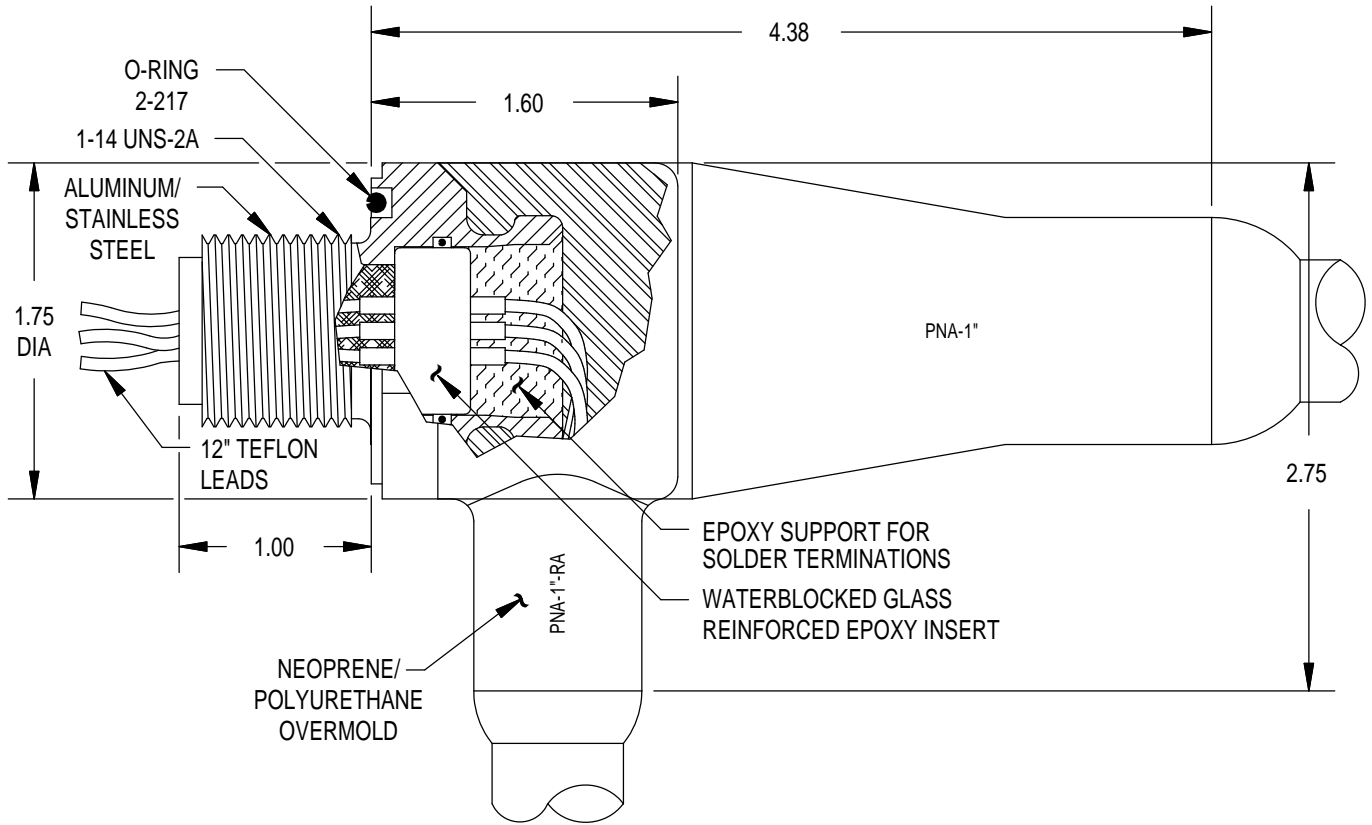

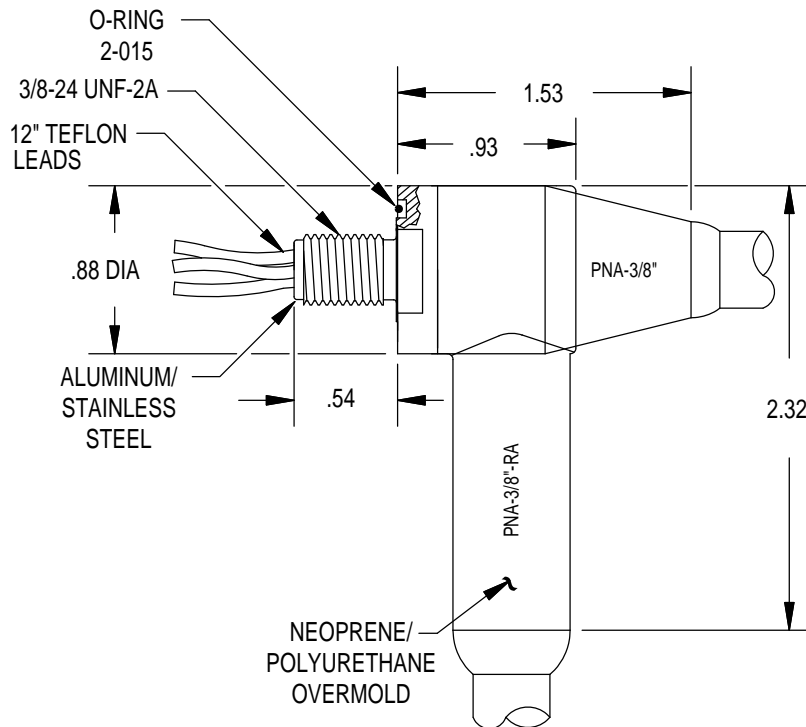
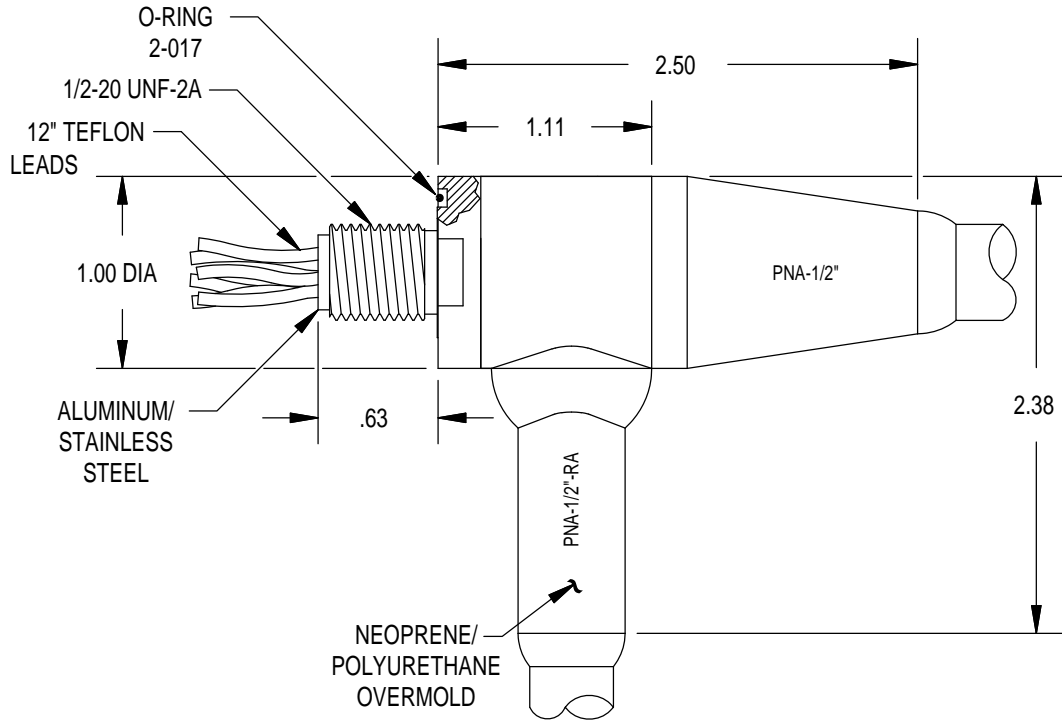

PNA SIZE	MOUNTING TORQUE FOR SS PNA (in lbs)	MOUNTING TORQUE FOR ALUMINUM PNA (in lbs)	PRESSURE RATING (psi)	MAXIMUM # OF CONTACTS
1"	200	150	10,000	30
3/4"	150	100	10,000	8
1/2"	125	80	10,000	9
3/8"	100	70	10,000	3(ALUM)/4(SS)

* Optional 5/8-18 UNF-2A stainless steel body available.

* Waterblocked glass reinforced epoxy insert available as separate item.

THIS PAGE INTENTIONALLY LEFT BLANK

DESCRIPTION AND MATERIAL	<ul style="list-style-type: none">• Molded neoprene, some types available in polyurethane.• Two to twelve contacts, 12 AWG. (LPIL/LPBH-12 has 16 AWG. contacts.)• Up to 750 VDC.• Up to 10,000 PSI.• Bulkhead connector design open face pressure rated to 5,000 PSI.• Contacts gold plated per MIL-G-45204.
CABLE	<ul style="list-style-type: none">• Connectors in this series are molded on a standard 24" length of 16 AWG SO cable. IL-5, IL-12, LPIL-5 are molded on a standard 24" length of 18 AWG SO cable. LPIL-12 is molded on a standard 24" length of 20 AWG cable.• Custom lengths and cable types are available on request.• Bulkhead connectors have 12" teflon leads, Type E per MIL 16878/4 18 AWG.
USES	<ul style="list-style-type: none">• Light to heavy duty applications.• Hazardous environments.
GUIDELINES	<ul style="list-style-type: none">• All mounting surfaces require a 32 finish.• Lubricate mating surfaces with 3M Silicone Lubricant or equivalent, DO NOT grease! Connectors must be lubricated on a regular basis.• Lubricate o-rings with Dow Corning #111 Valve Lubricant or equivalent.• Align index pin prior to mating.• Avoid nicks and cuts around contacts as these are the sealing surfaces.• Elastomers can be seriously degraded if exposed to direct sunlight or high ozone levels for extended periods of time.• Do not over tighten bulkhead nuts.• Do not pull on cable to disconnect.• Avoid sharp bends at cable entry to connector.
ORDERING INFORMATION	<ul style="list-style-type: none">• Locking sleeves are optional, specify when ordering.• Bulkhead connectors do not come with nuts and washers. If required, please specify when ordering.• OM connectors do not come with overmolding boots. If required, please specify when ordering.
NOTE	<ul style="list-style-type: none">• For Mini Wet Pluggable see Technical Bulletin page 65 80• For Micro Mini Wet Pluggable see Technical Bulletin page 65 109

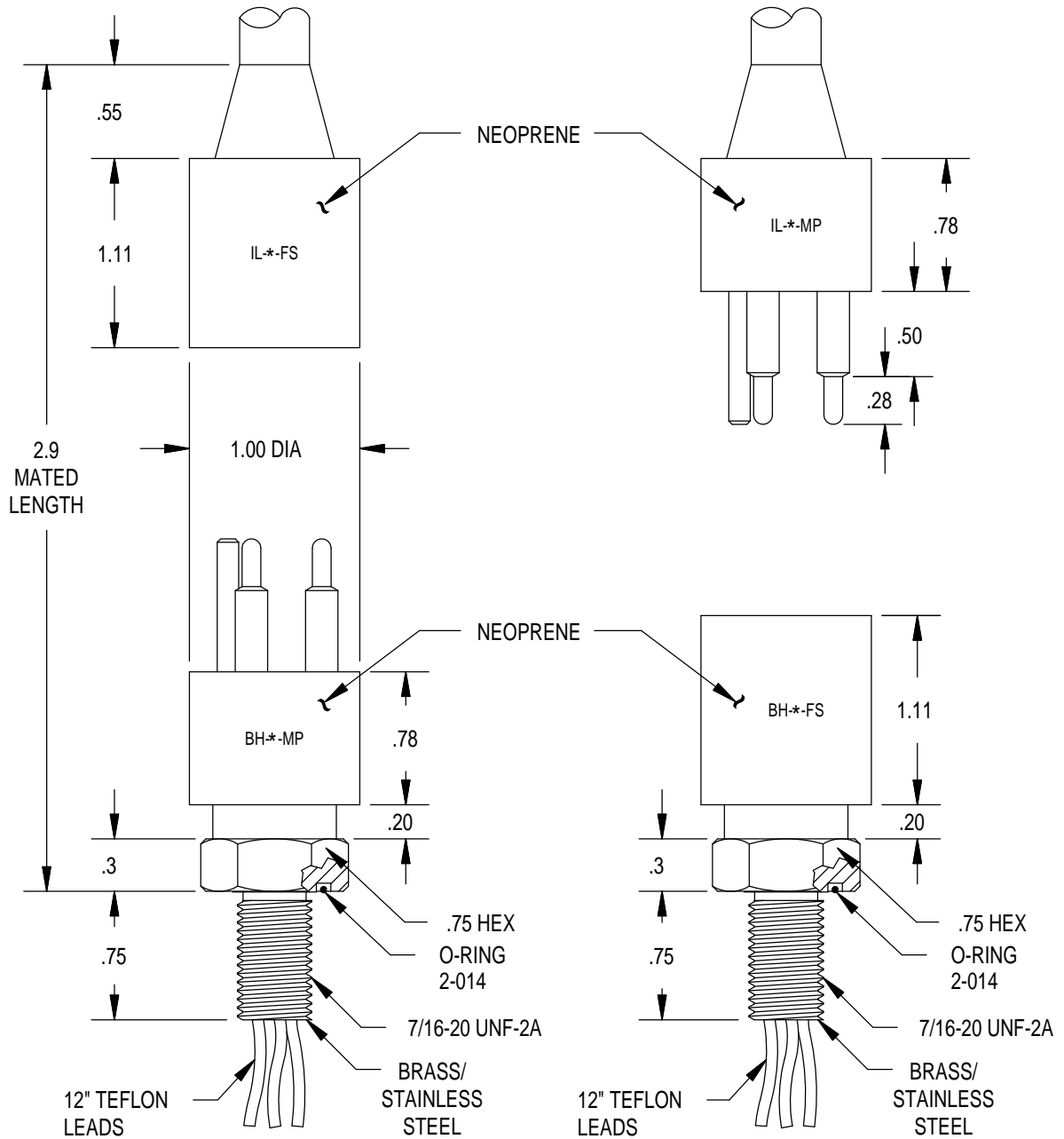

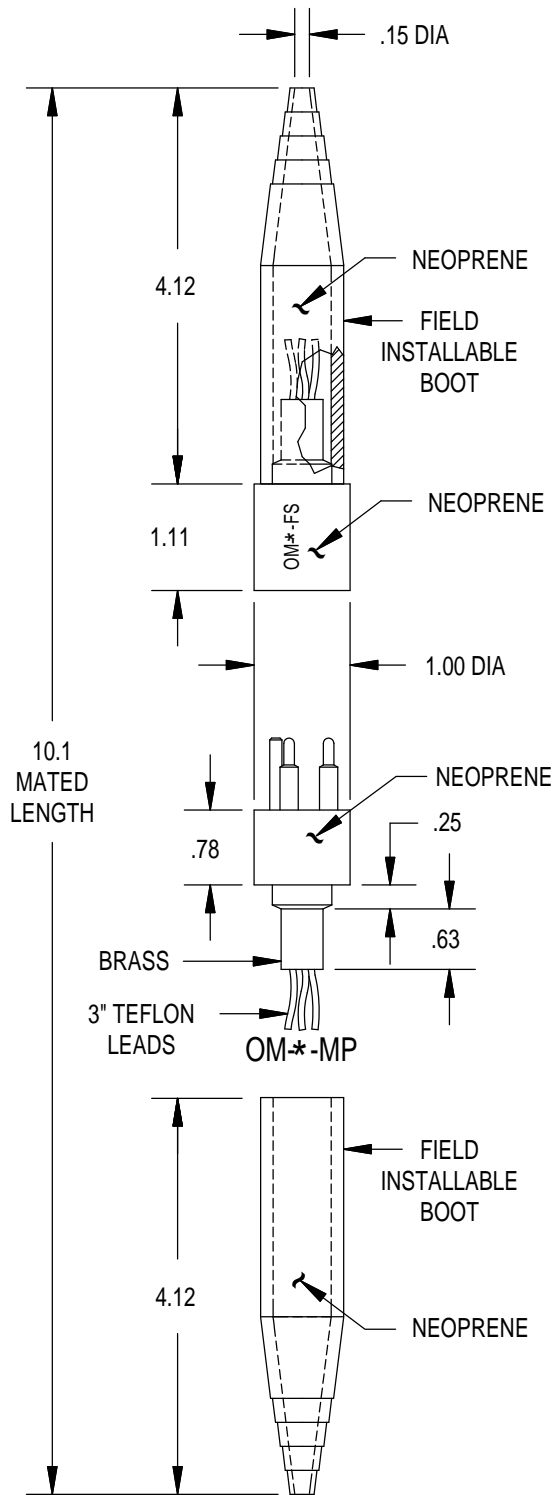

CONTACT CONFIGURATION
(MP FACE VIEWS)

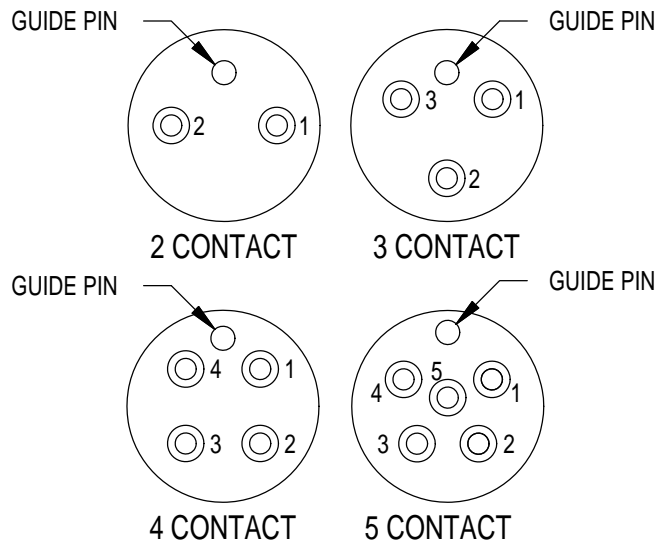

MOUNTING TORQUE FOR BH-FS/MP	not to exceed 100 in lbs
MATED PRESSURE RATING (psi)	10,000
DUMMY PLUG FOR BH-FS, IL-FS, OM-FS	DC*-MP
DUMMY PLUG FOR BH-MP, IL-MP, OM-MP	DC*-FS
NOTE: Delrin locking sleeves available (DLSA-M or F).	
* Specify number of contacts.	
* Dummy Plugs found on page 65 32.	

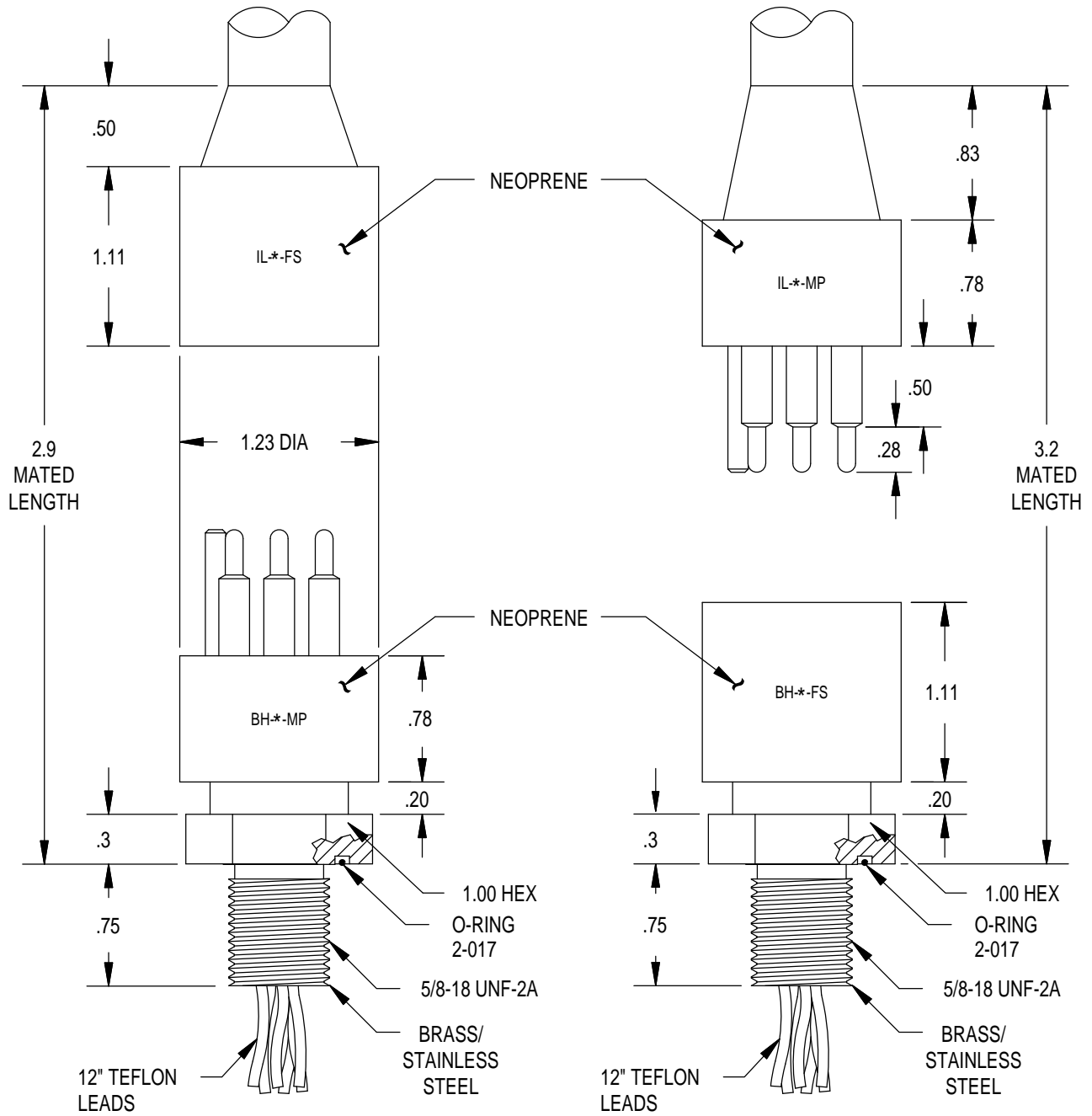

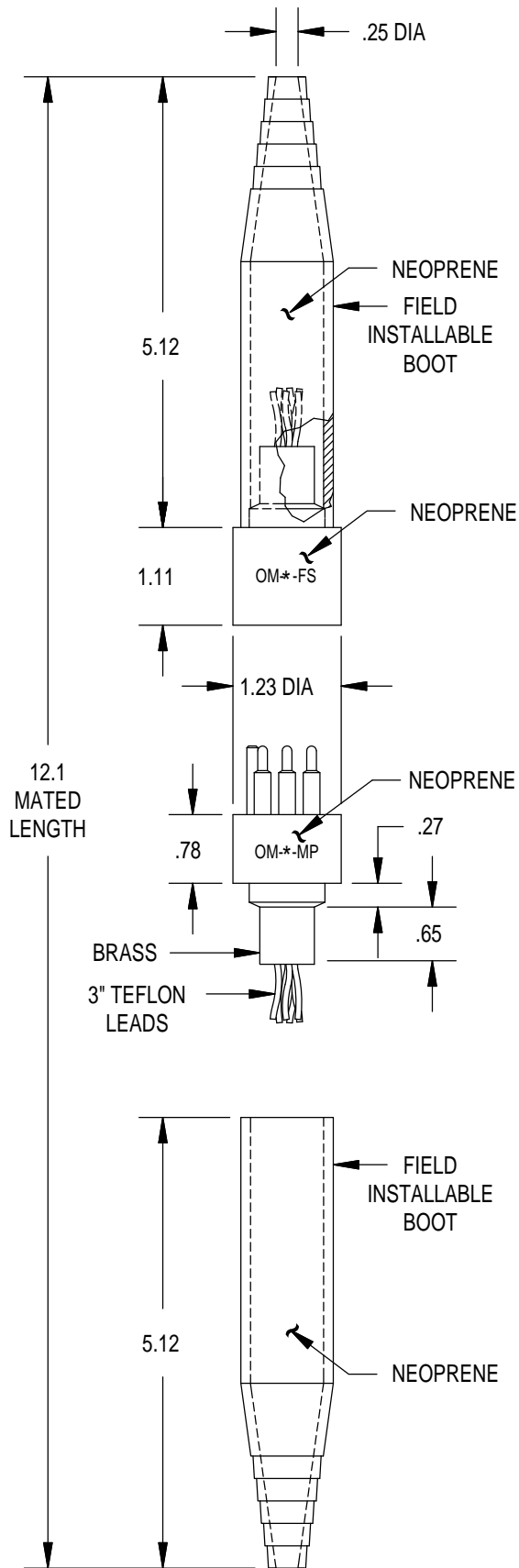

**CONTACT
CONFIGURATION
(MP FACE VIEWS)**

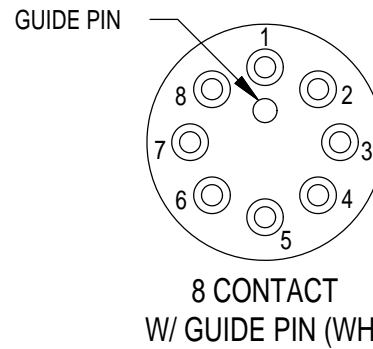
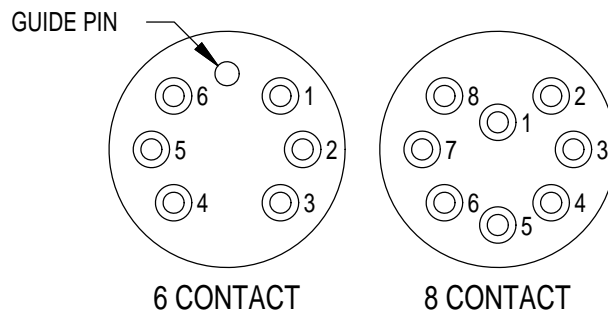

MOUNTING TORQUE FOR BH-FS/MP	not to exceed 100 in lbs
MATED PRESSURE RATING (psi)	10,000
DUMMY PLUG FOR BH-FS, IL-FS, OM-FS	DC*-MP
DUMMY PLUG FOR BH-MP, IL-MP, OM-MP	DC*-FS
NOTE: Delrin locking sleeves available (DLSB-M or F).	
* Specify number of contacts.	
* Dummy Plugs found on page 65 32.	

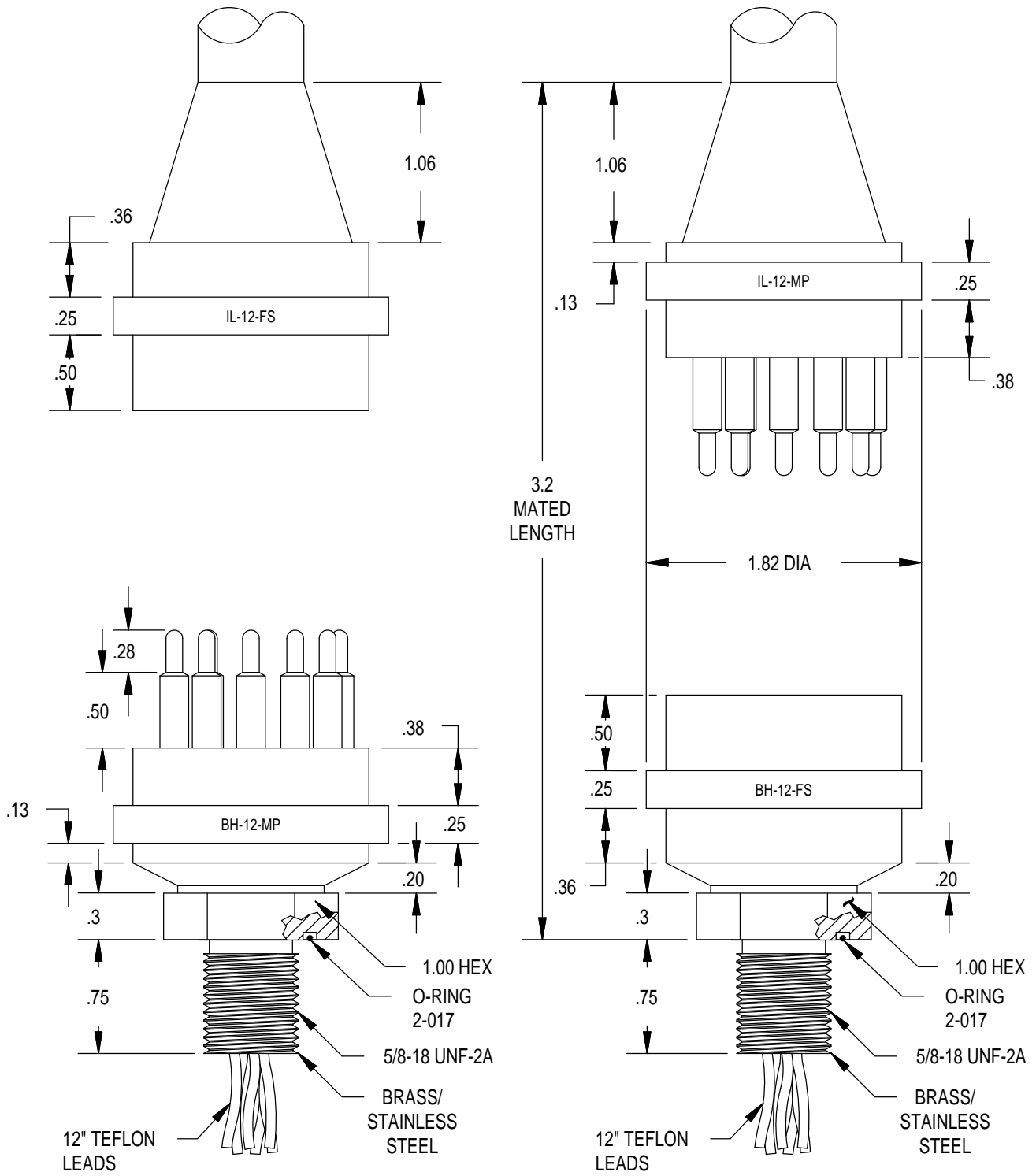

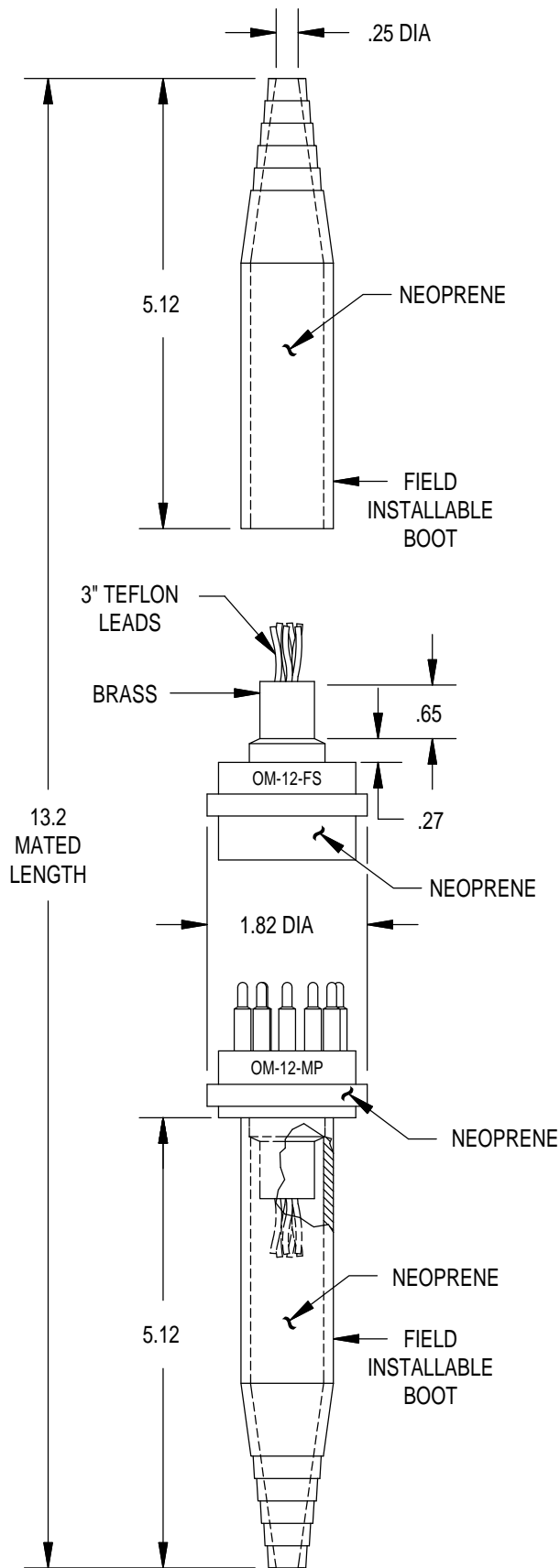

**CONTACT
CONFIGURATION**
(MP FACE VIEW)

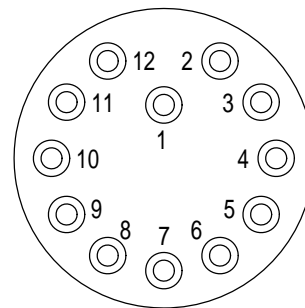

12 CONTACT

MOUNTING TORQUE FOR BH-FS/MP	not to exceed 100 in lbs
MATED PRESSURE RATING (psi)	10,000
DUMMY PLUG FOR BH-FS, IL-FS, OM-FS	DC-12-MP
DUMMY PLUG FOR BH-MP, IL-MP, OM-MP	DC-12-FS
NOTE: Delrin locking sleeve available (DLSC-M or F). * Dummy Plugs found on page 65 33.	

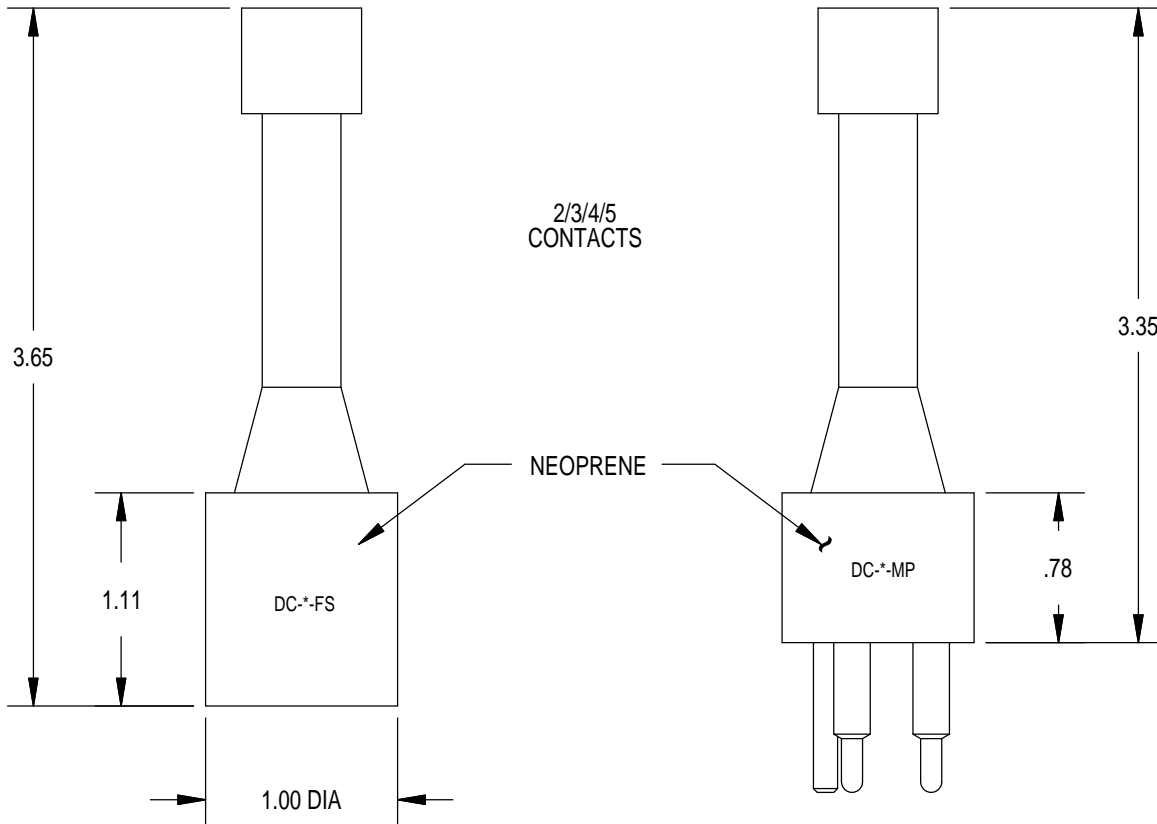

*SPECIFY NUMBER OF CONTACTS

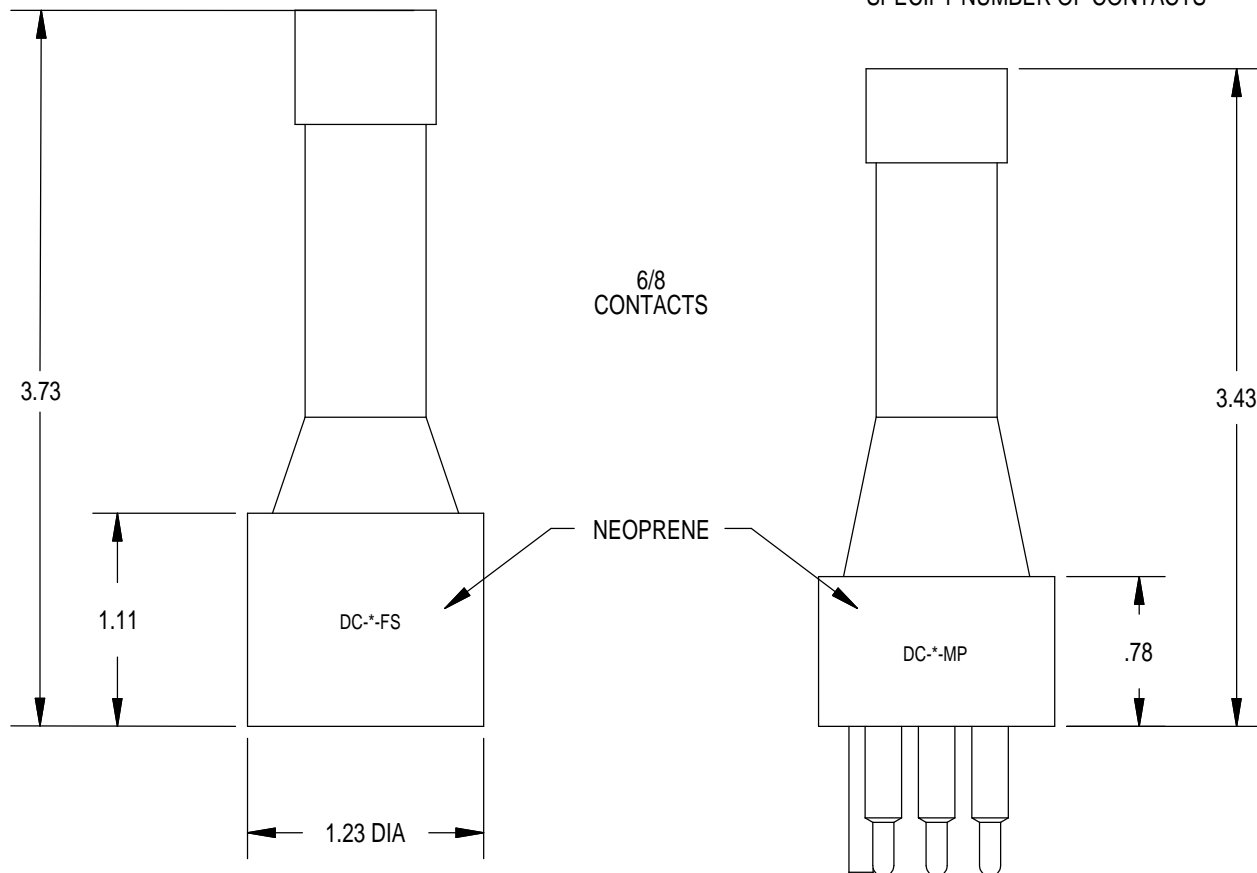

DC-12

WET
PLUGGABLE SERIES

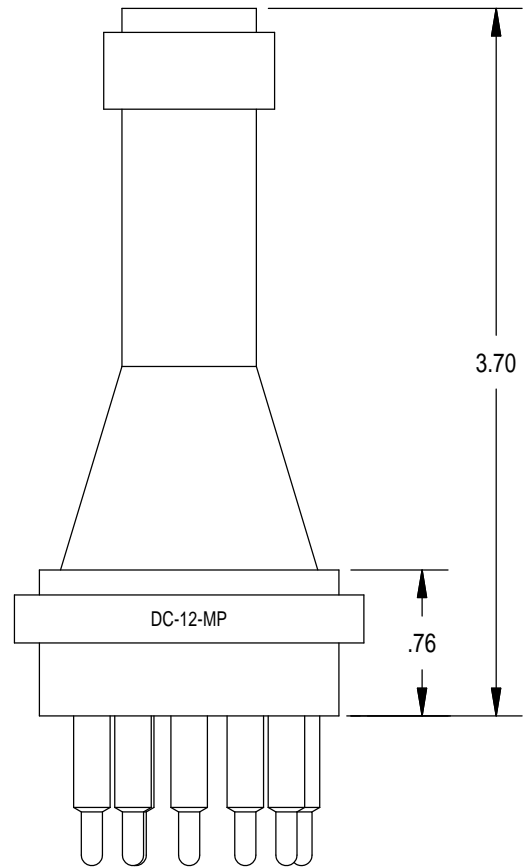
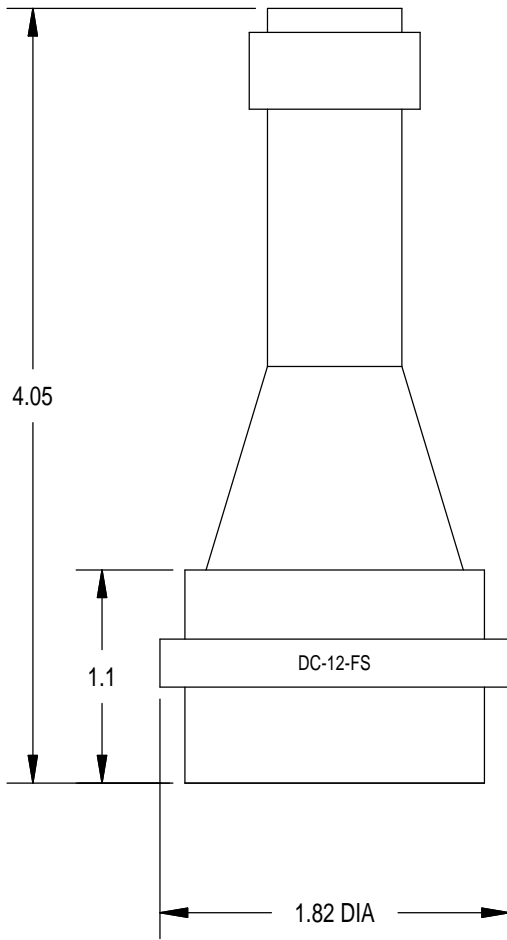

DELTRIN LOCKING SLEEVES

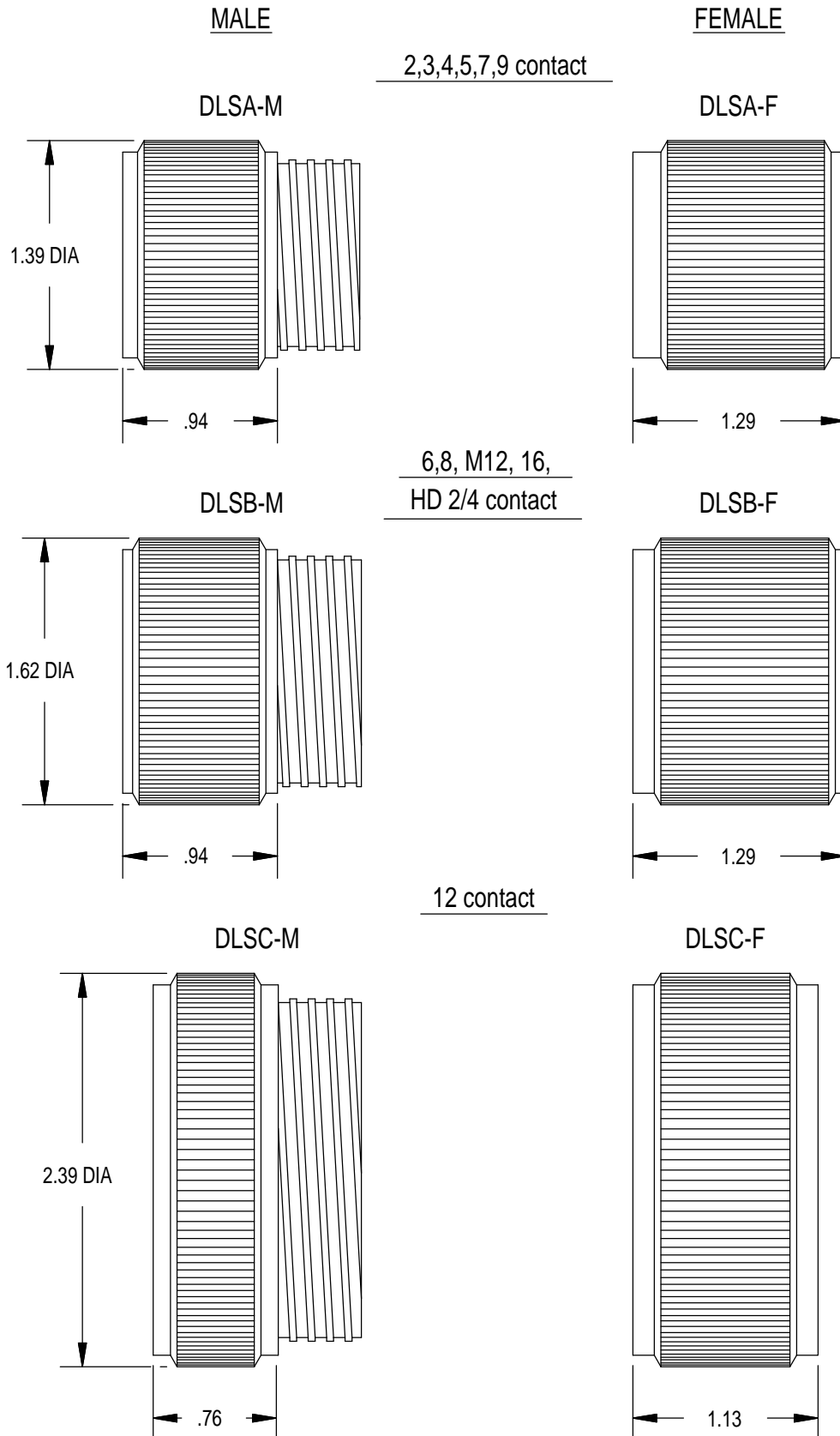

THIS PAGE INTENTIONALLY LEFT BLANK

**CONTACT
CONFIGURATION**
(MP FACE VIEWS)

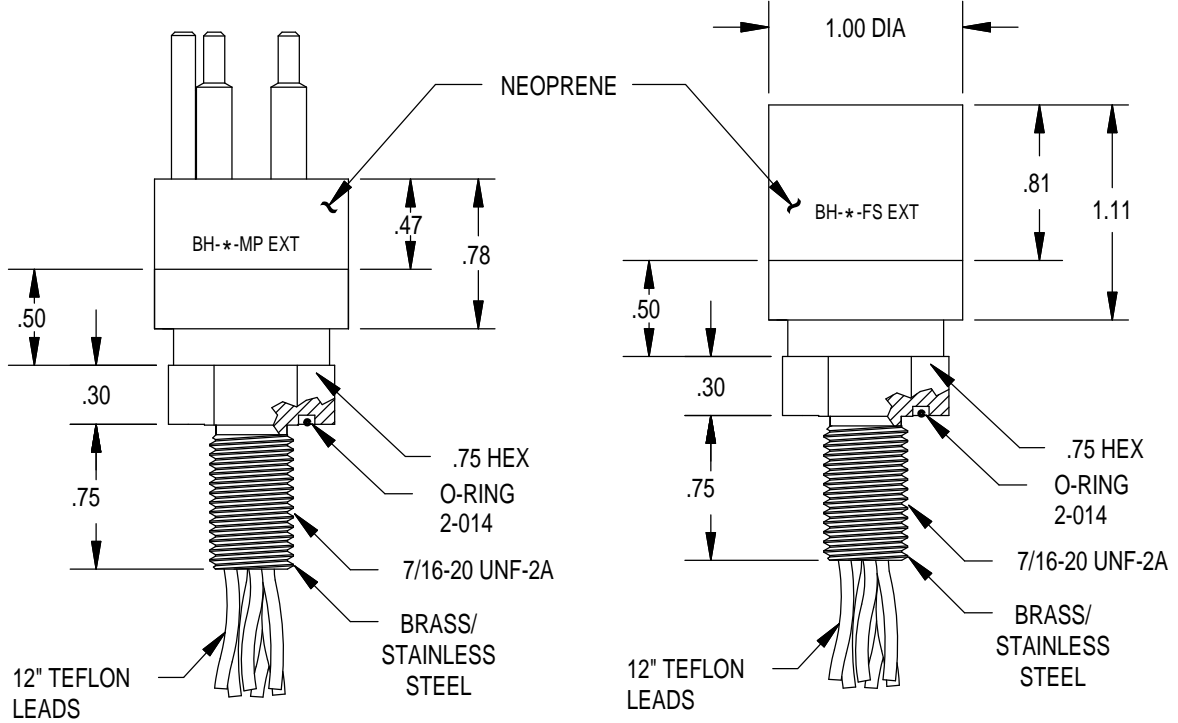
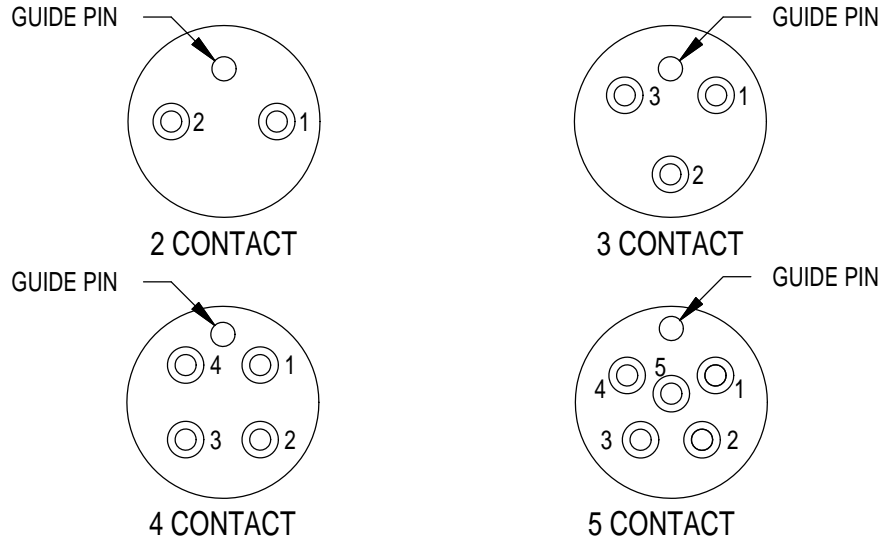

NOTE: For mating connectors see page 65 10
 For dummy connectors see page 65 32
 Delrin locking sleeves available (DLSA-M or F) see Page 65 35

CONTACT
CONFIGURATION
(MP FACE VIEWS)

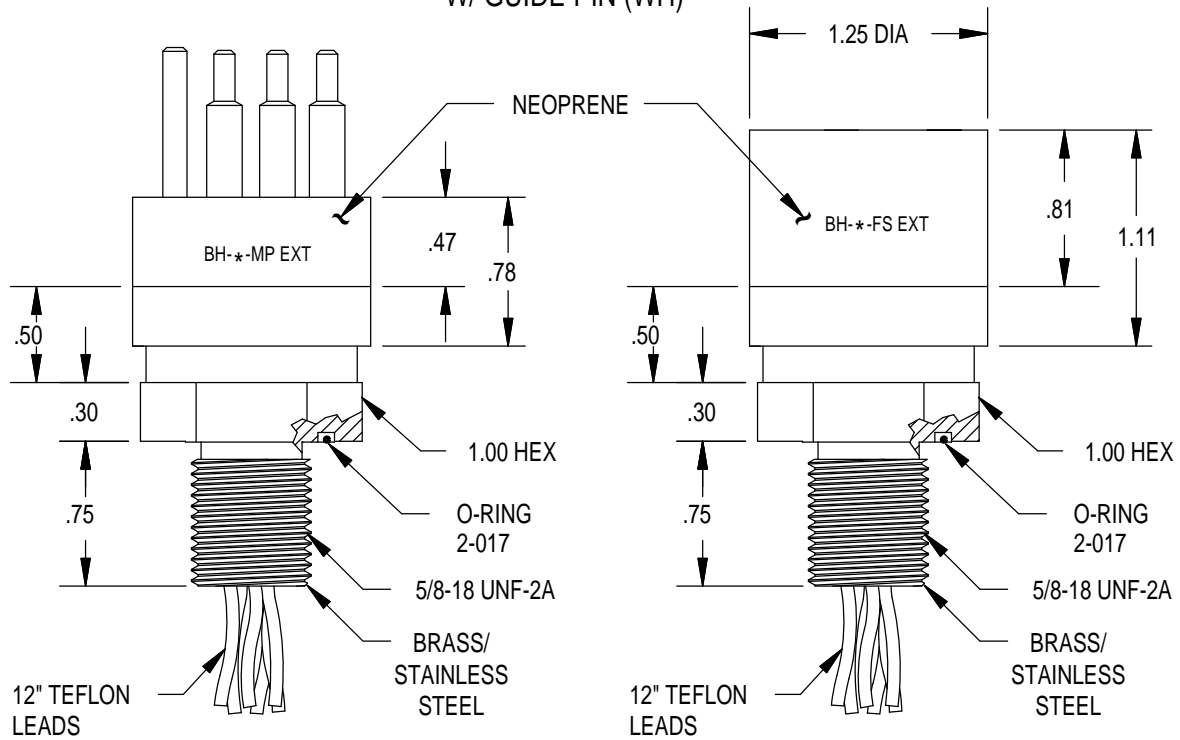
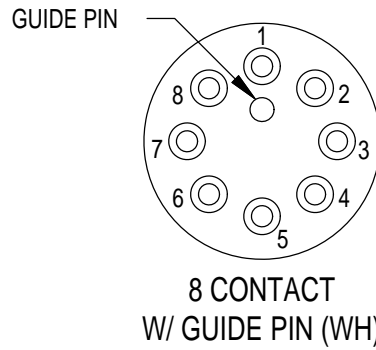
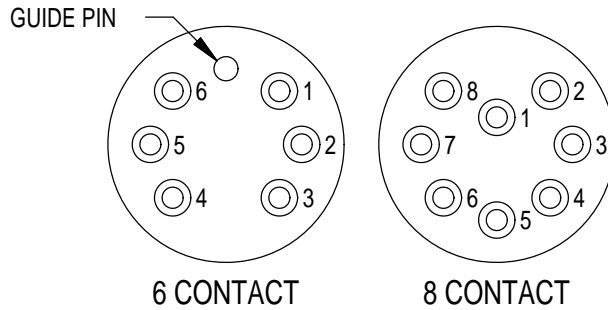

NOTE: For mating connectors see page 65 20
 For dummy connectors see page 65 32
 Delrin locking sleeves available (DLSB-M or F) see Page 65 35

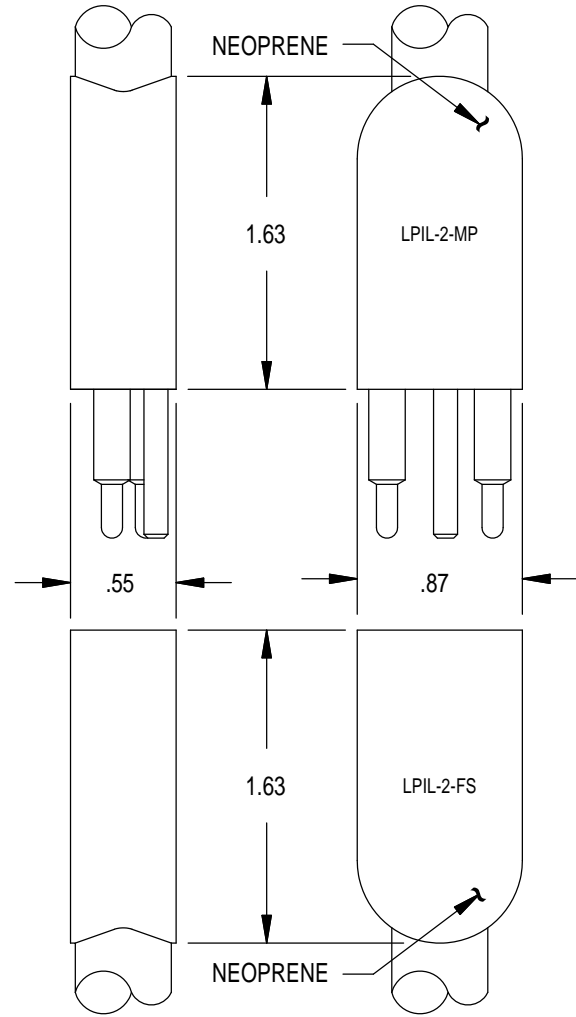
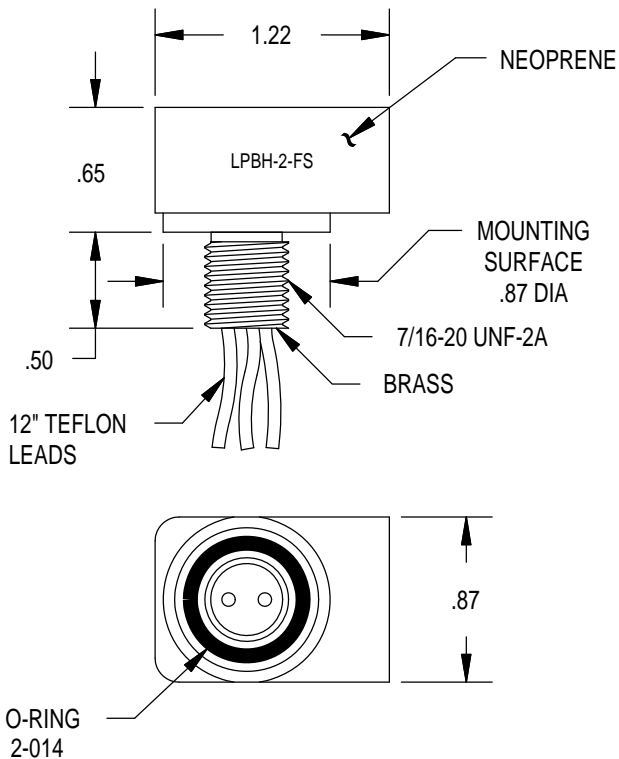
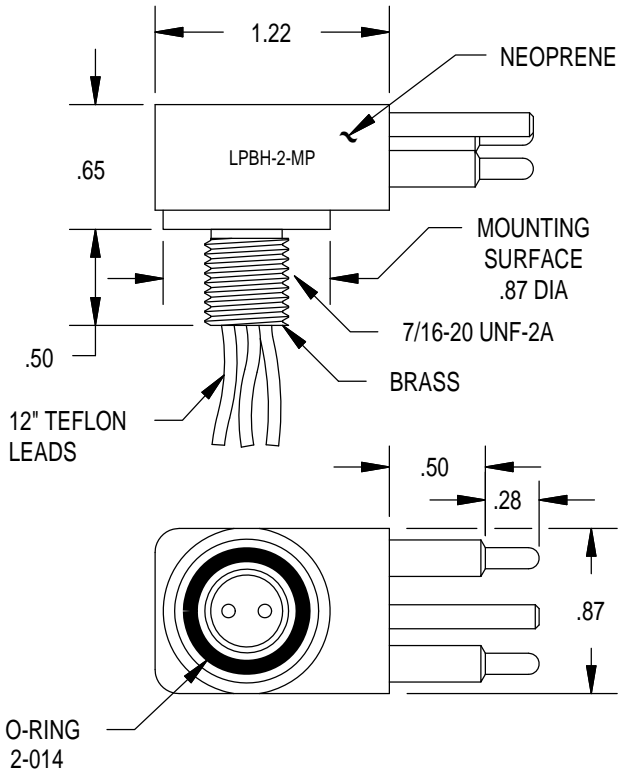

**CONTACT
CONFIGURATION**
(MP FACE VIEW)

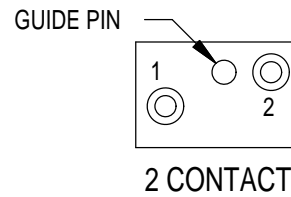

MOUNTING TORQUE FOR LPBH-FS/MP	not to exceed 100 in lbs
MATED PRESSURE RATING (psi)	10,000
DUMMY PLUG FOR LPBH-2-FS, LPIL-2-FS	LPDC-2-MP
DUMMY PLUG FOR LPBH-2-MP, LPIL-2-MP	LPDC-2-FS
NOTE: Bulkhead body available in stainless steel. Standard 1/2" thread length. * Dummy Plugs found on page 65 71.	

LPBH/LPIL-3/4/5

LOW PROFILE WET
PLUGGABLE SERIES

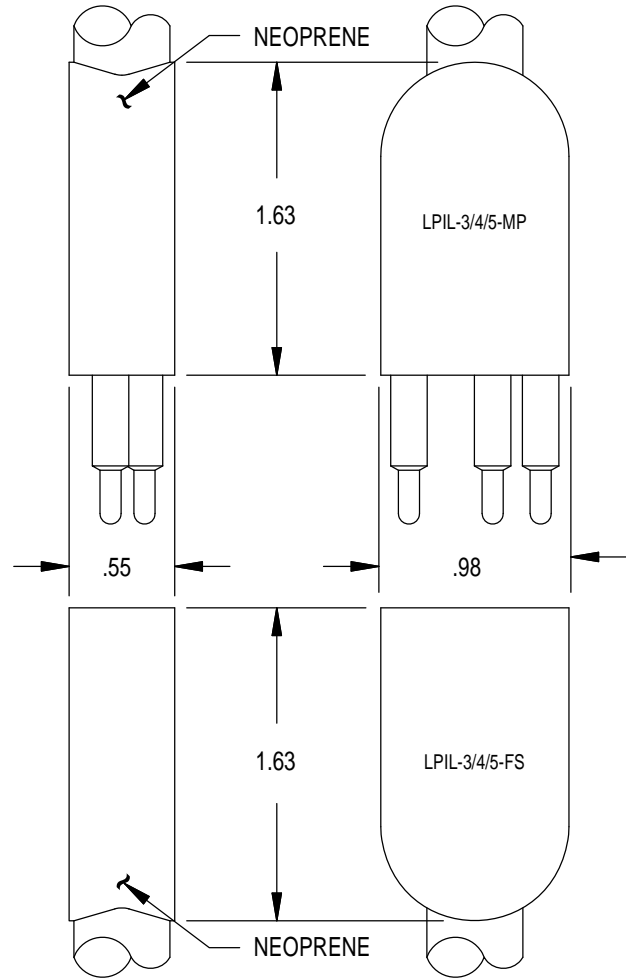
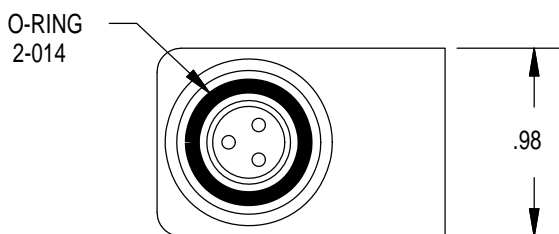
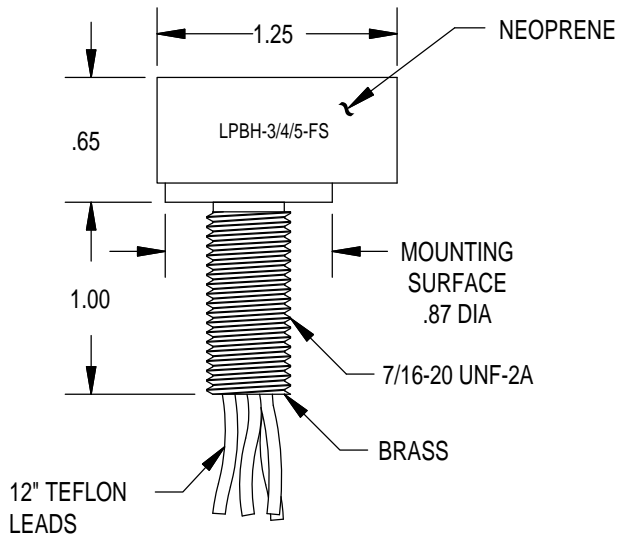
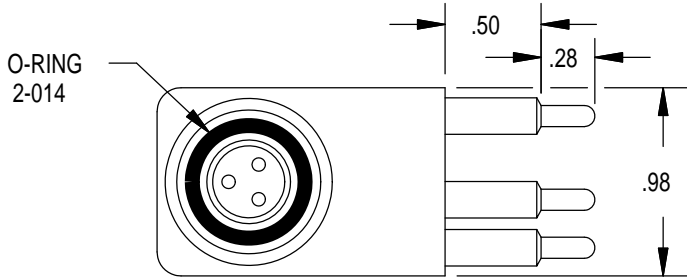
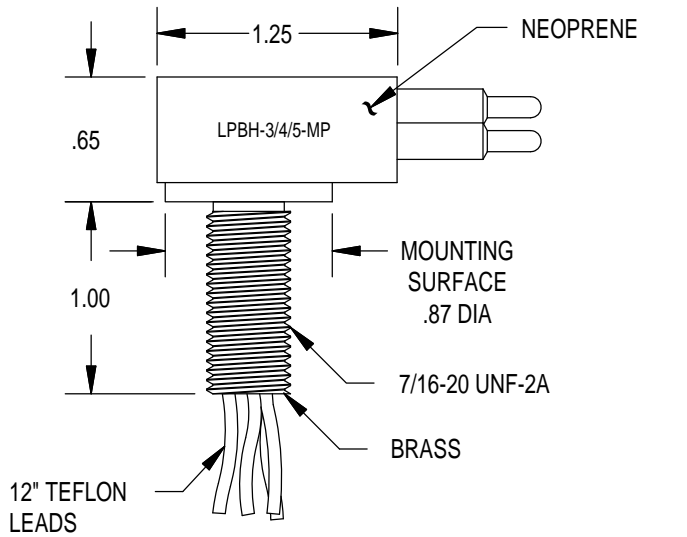

CONTACT CONFIGURATION (MP FACE VIEWS)

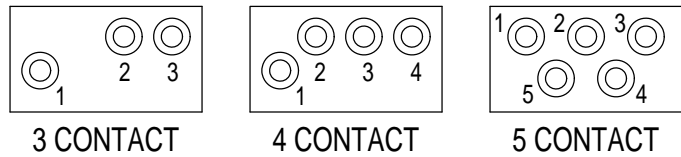

MOUNTING TORQUE FOR LPBH-FS/MP	not to exceed 100 in lbs
MATED PRESSURE RATING (psi)	10,000
DUMMY PLUG FOR LPBH-3/4/5-FS, LPIL-3/4/5-FS	LPDC-3/4/5-MP
DUMMY PLUG FOR LPBH-3/4/5-MP, LPIL-3/4/5-MP	LPDC-3/4/5-FS
NOTE: Bulkhead body available in stainless steel. Standard 1" thread length. * Dummy Plugs found on page 65 71.	

LPBH/LPIL-7

LOW PROFILE WET
PLUGGABLE SERIES

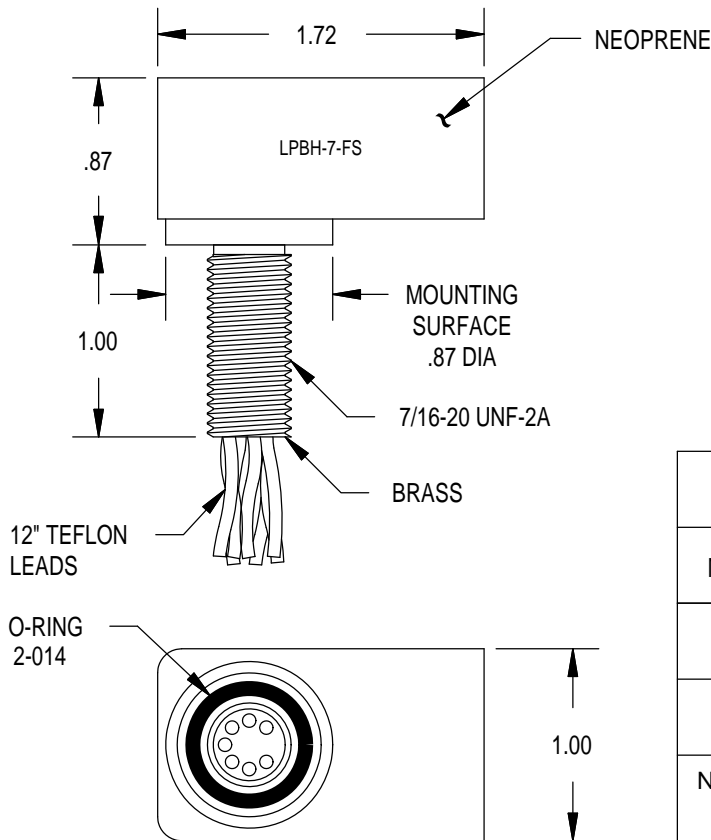
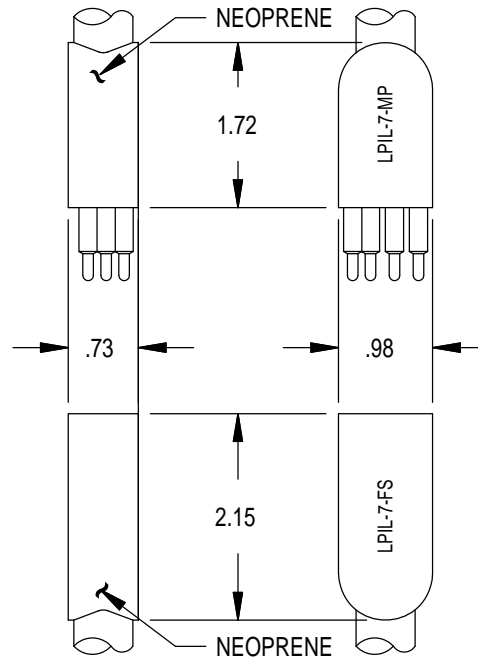
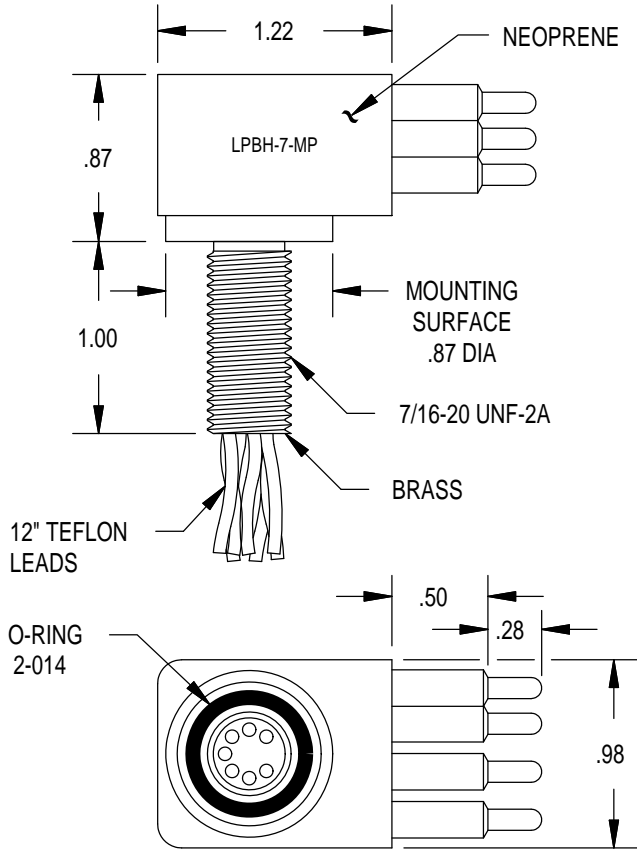

CONTACT CONFIGURATION (MP FACE VIEW)

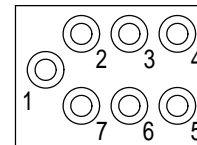

7 CONTACT

MOUNTING TORQUE FOR LPBH-FS/MP	not to exceed 100 in lbs
MATED PRESSURE RATING (psi)	10,000
DUMMY PLUG FOR LPBH-7-FS, LPIL-7-FS	LPDC-7-MP
DUMMY PLUG FOR LPBH-7-MP, LPIL-7-MP	LPDC-7-FS
NOTE: Bulkhead body available in stainless steel. Standard 1" thread length. * Dummy Plugs found on page 65 72.	

LPBH/LPIL-9/12

LOW PROFILE WET
PLUGGABLE SERIES

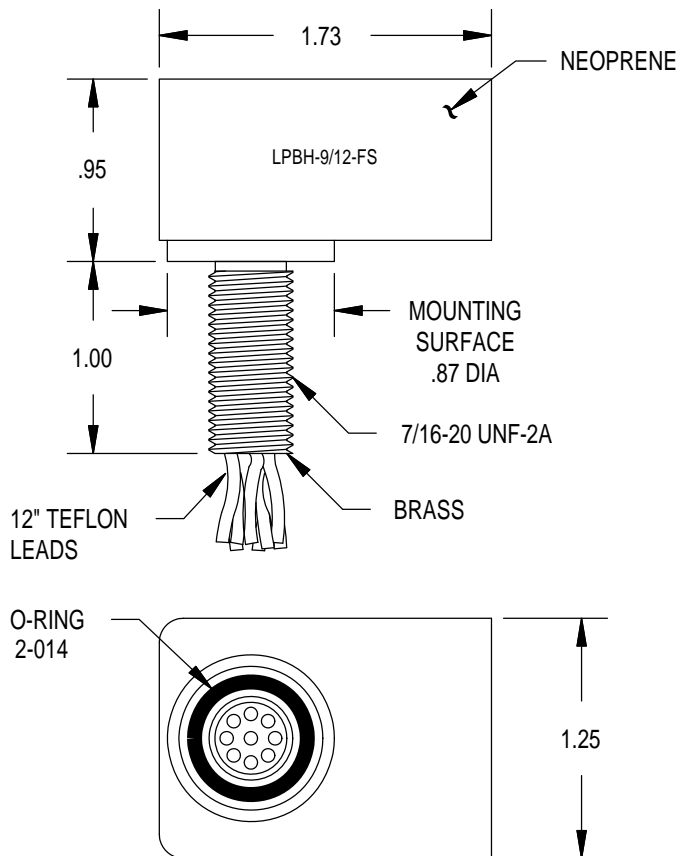
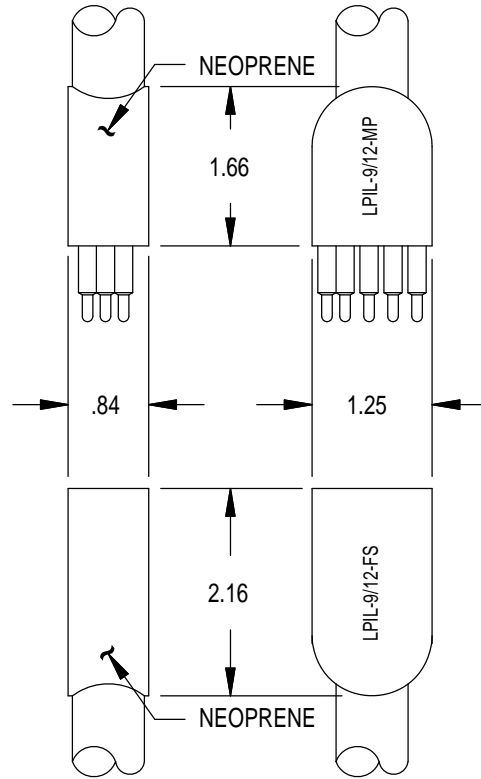
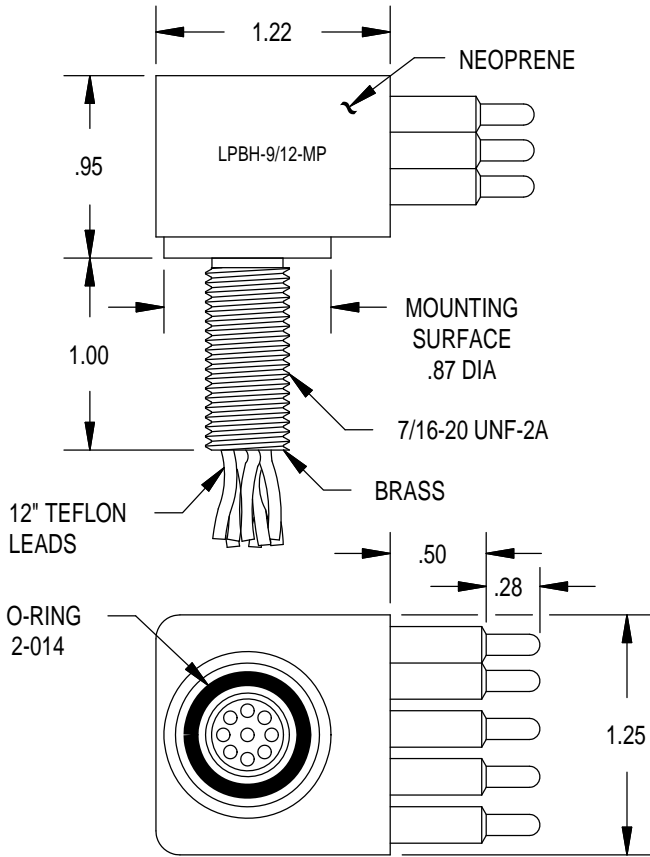

CONTACT CONFIGURATION (MP FACE VIEW)

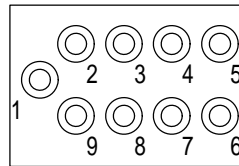

9 CONTACT

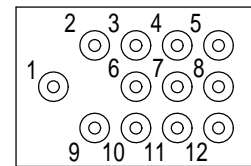

12 CONTACT

MOUNTING TORQUE FOR LPBH-FS/MP	not to exceed 100 in lbs
MATED PRESSURE RATING (psi)	10,000
DUMMY PLUG FOR LPBH-9-FS, LPIL-9-FS	LPDC-9-MP
DUMMY PLUG FOR LPBH-9-MP, LPIL-9-MP	LPDC-9-FS
NOTE: Bulkhead body available in stainless steel. Standard 1" thread length. * Dummy Plugs found on page 65 73.	

LPDC-2/3/4/5

LOW PROFILE WET
PLUGGABLE SERIES

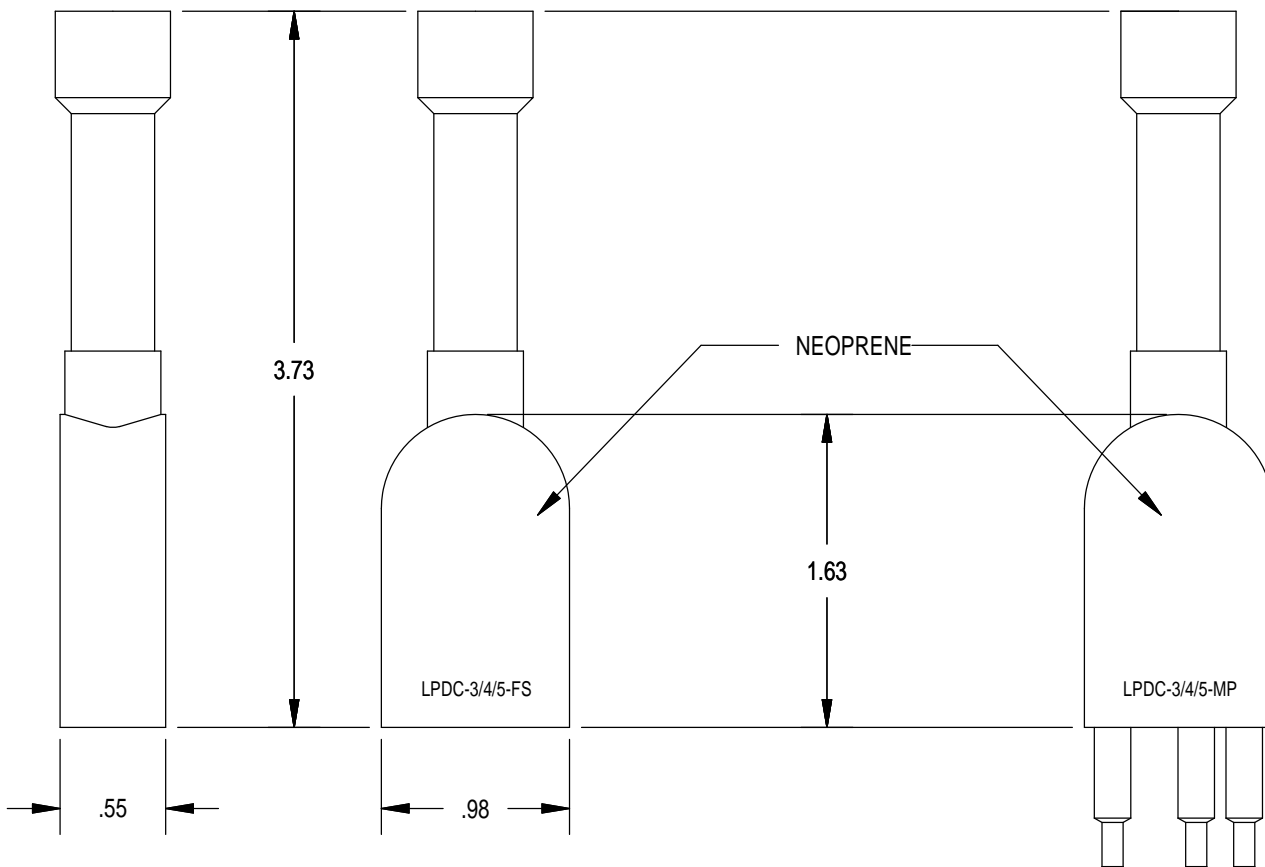
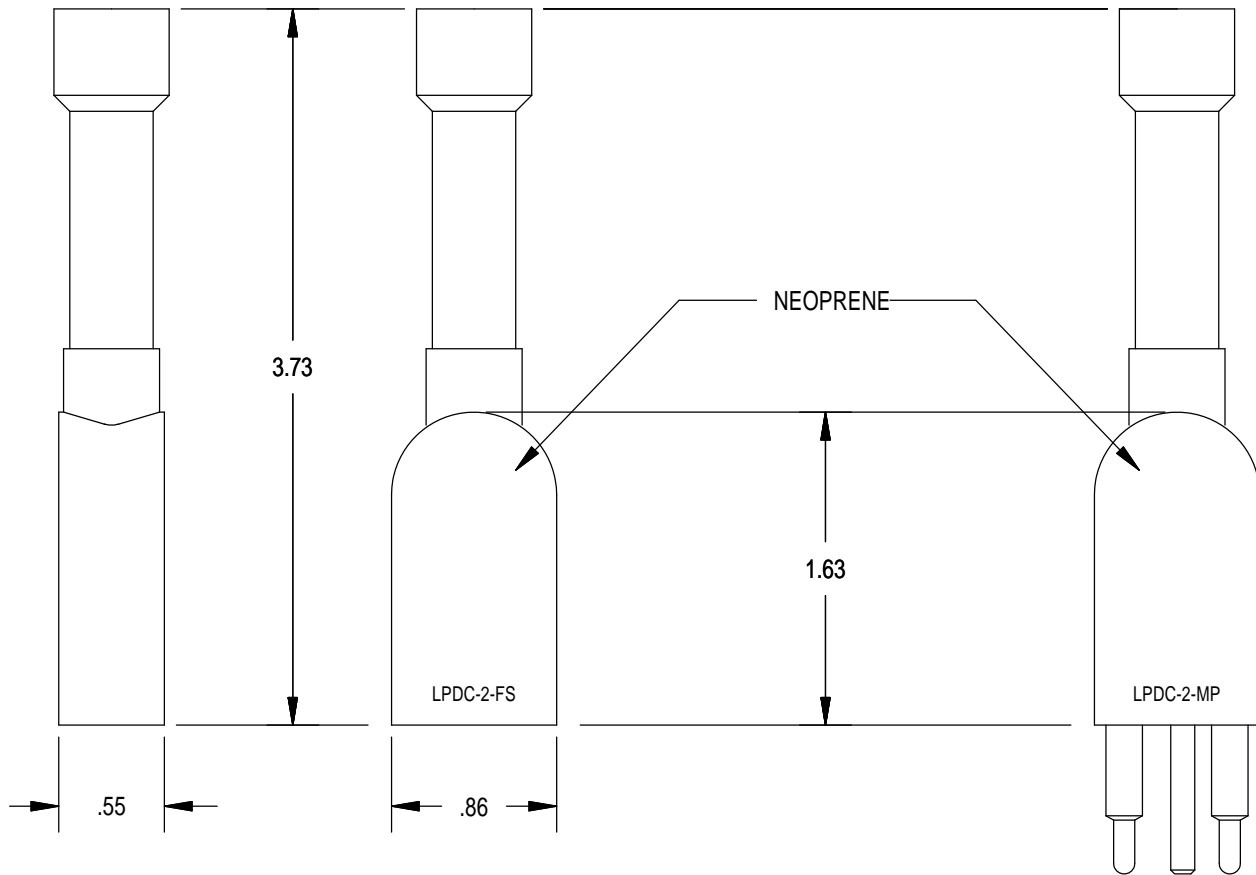

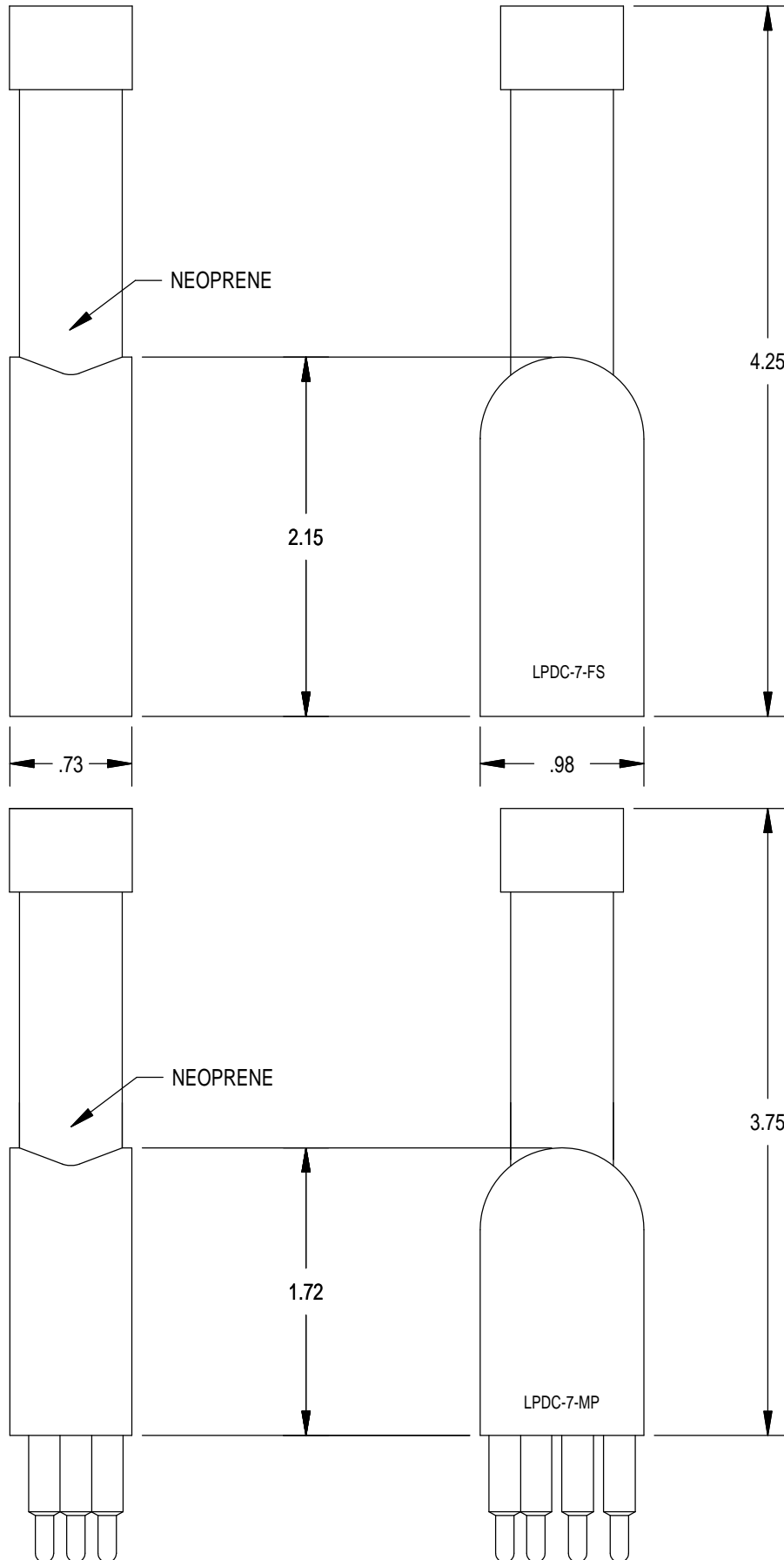

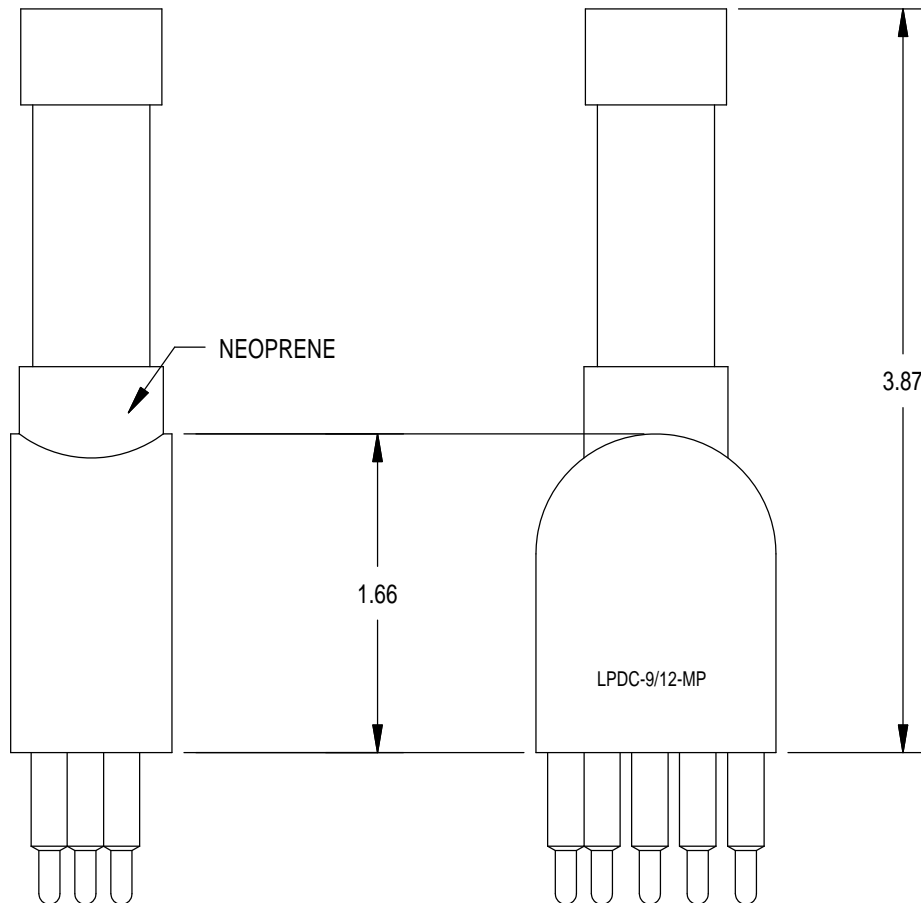
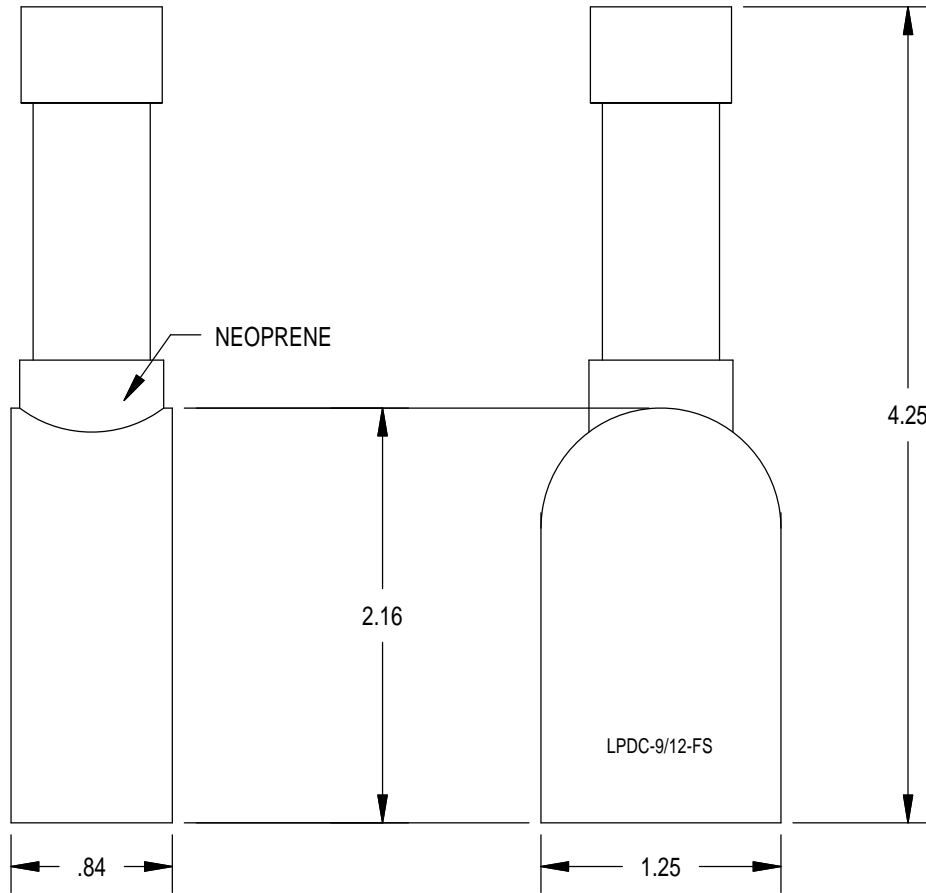

DESCRIPTION AND MATERIAL	<ul style="list-style-type: none">• Molded neoprene or polyurethane.• Two to eighteen contacts, 16 AWG.• Up to 750 VDC.• Up to 10,000 PSI, mated.• Bulkhead connector design open face pressure rated to 5000 PSI.• Contacts gold plated per MIL-G-45204.
CABLE	<ul style="list-style-type: none">• Inline connectors in this series are molded on a standard 24" length of cable, #20 AWG, unless otherwise specified.• Bulkhead connectors have 12" teflon leads, Type E per MIL 16878/4, 18 AWG.
USES	<ul style="list-style-type: none">• Light to medium duty applications.• Hazardous environments.
GUIDELINES	<ul style="list-style-type: none">• All mounting surfaces require a 32 finish.• Lubricate mating surface with 3M Silicone Lubricant or equivalent, DO NOT grease! Connectors must be lubricated on a regular basis.• Lubricate o-ring with Dow Corning #111 Valve Lubricant or equivalent.• Replace o-rings when re-using connectors.• Avoid nicks and cuts around contacts as these are the sealing surfaces.• Elastomers can be seriously degraded if exposed to direct sunlight or high ozone levels for extended periods of time.• Connectors should not be allowed to dry out. If this occurs soak in water before use.• Do not over tighten bulkhead nuts.• Do not pull on cable to disconnect.• Avoid sharp bends at cable entry to connector.
ORDERING INFORMATION	<ul style="list-style-type: none">• Bulkhead connectors do not come with nuts and washers. Nuts and washers should be ordered separately.

LPMBH/LPMIL

MINI WET PLUGGABLE SERIES

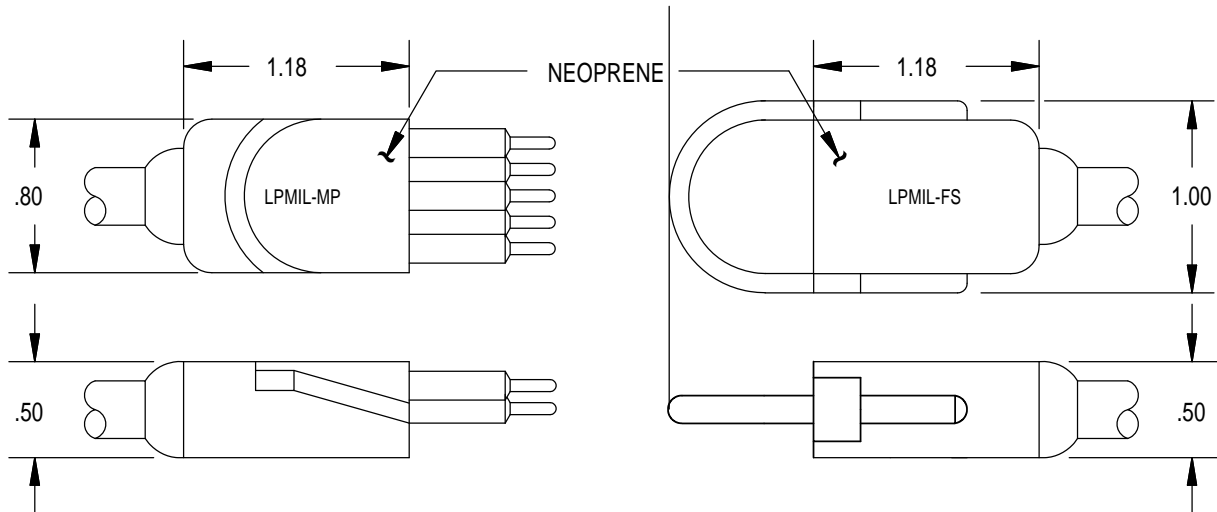
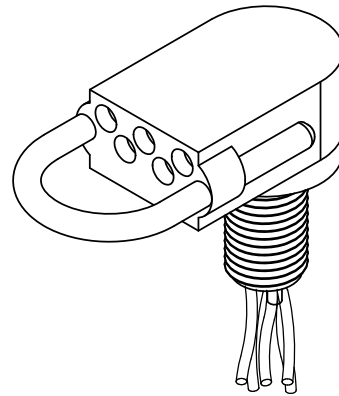
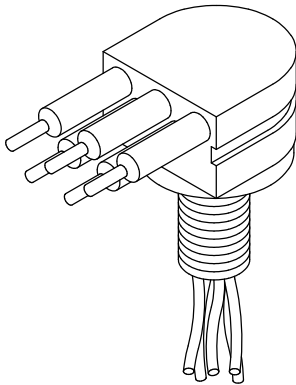
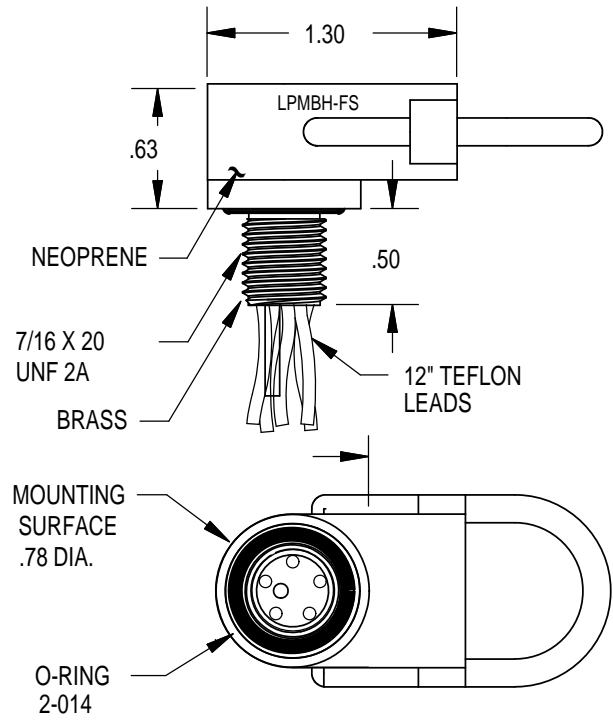
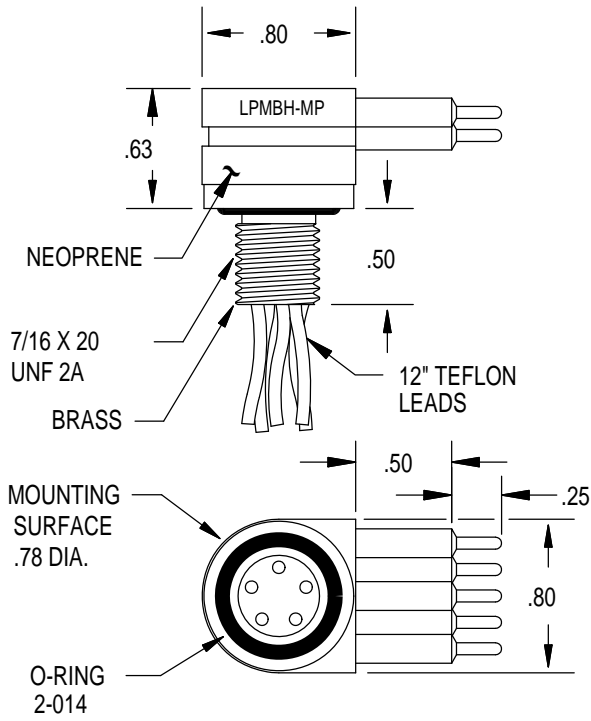

**CONTACT
CONFIGURATION**
(MP FACE VIEWS)

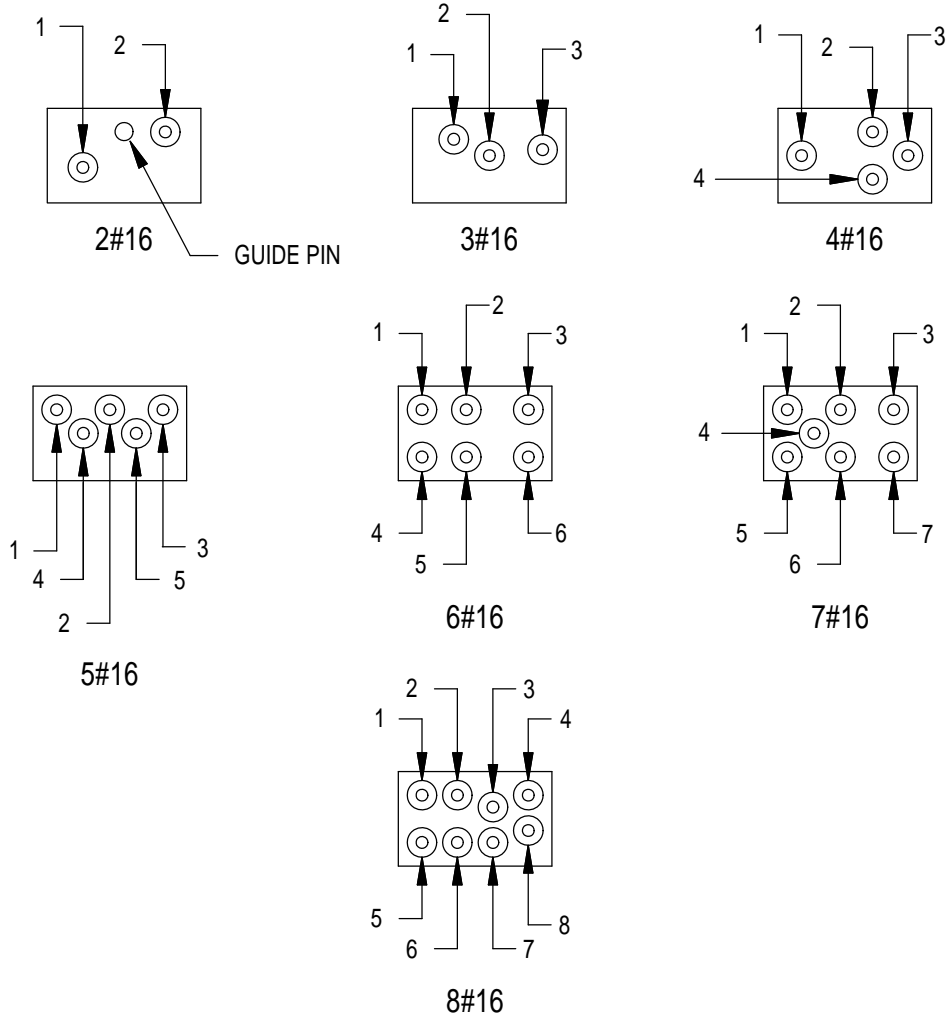

MOUNTING TORQUE LPMBH	not to exceed 100 in lbs	MATED PRESSURE RATING (psi)	10,000
DUMMY PLUG FOR LPMBH-MP, LPMIL-MP	LPMDC-**-FS	DUMMY PLUG FOR LPMBH-FS, LPMIL-FS	LPMDC-**-MP
<p>NOTE: Standard 1/2" thread length. * Specify number of contacts. * Dummy plugs found on page 65 83.</p>			

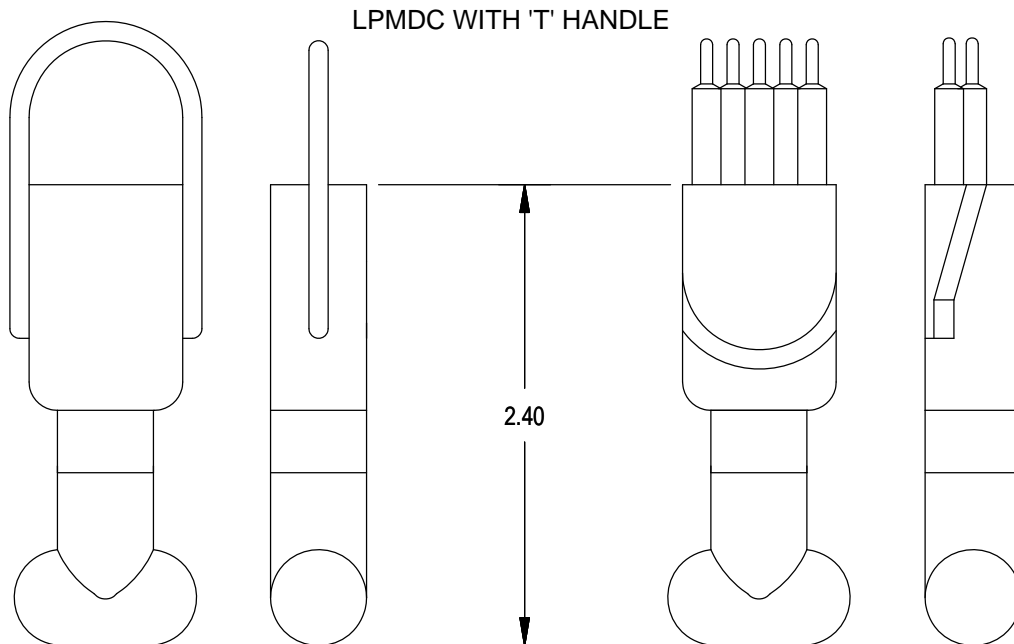
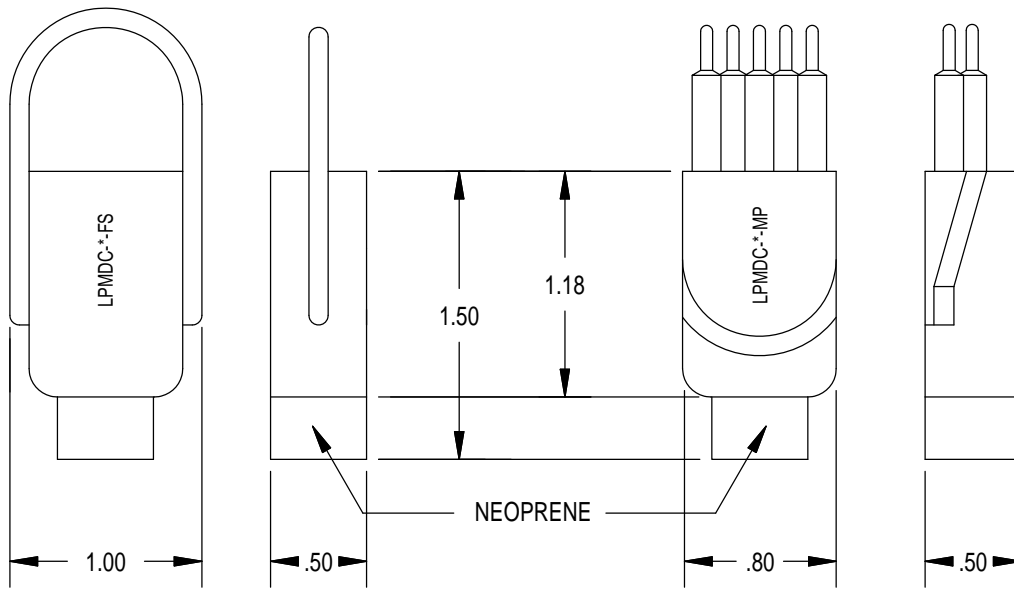

* Specify number of contacts.

THIS PAGE INTENTIONALLY LEFT BLANK

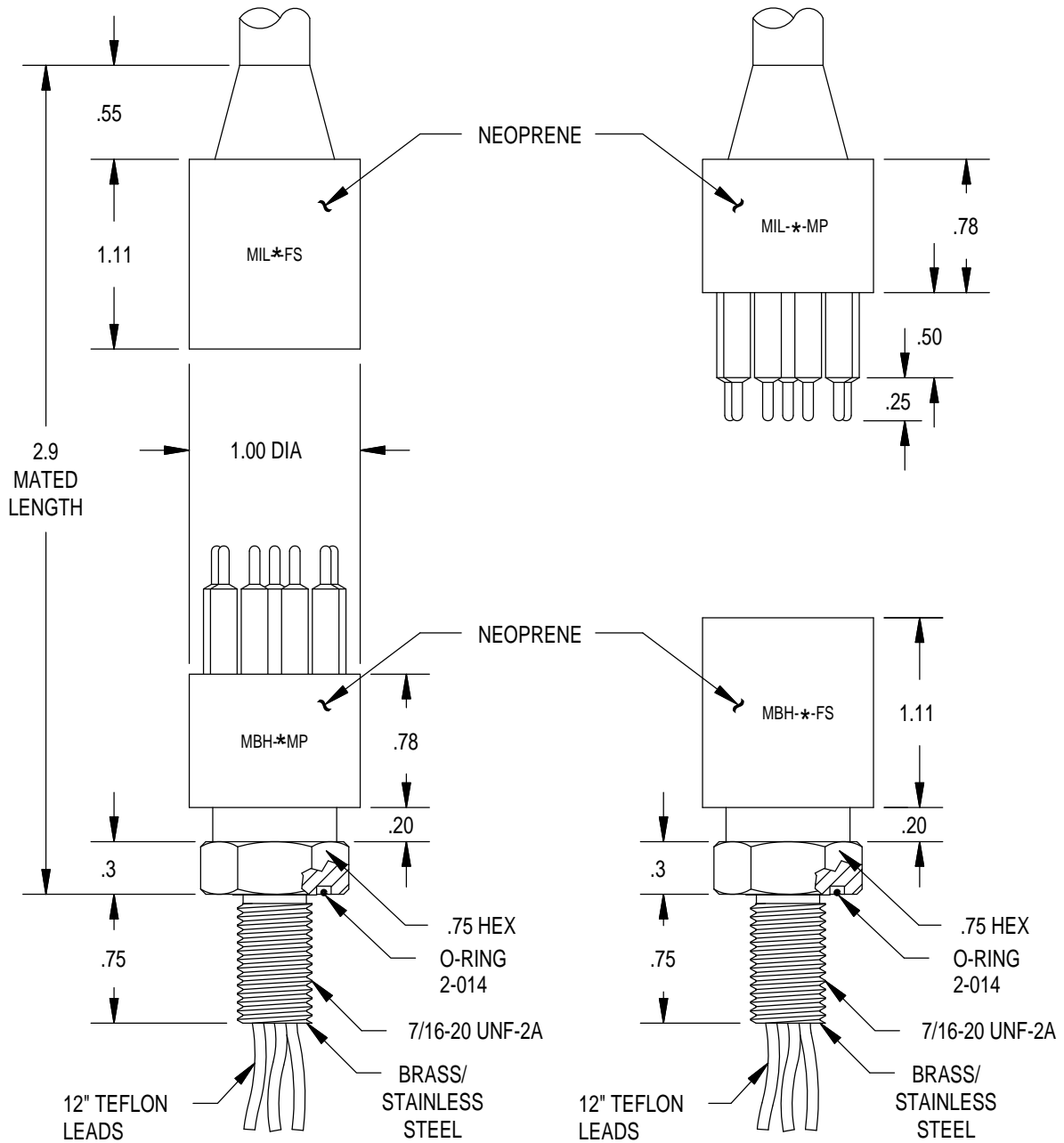

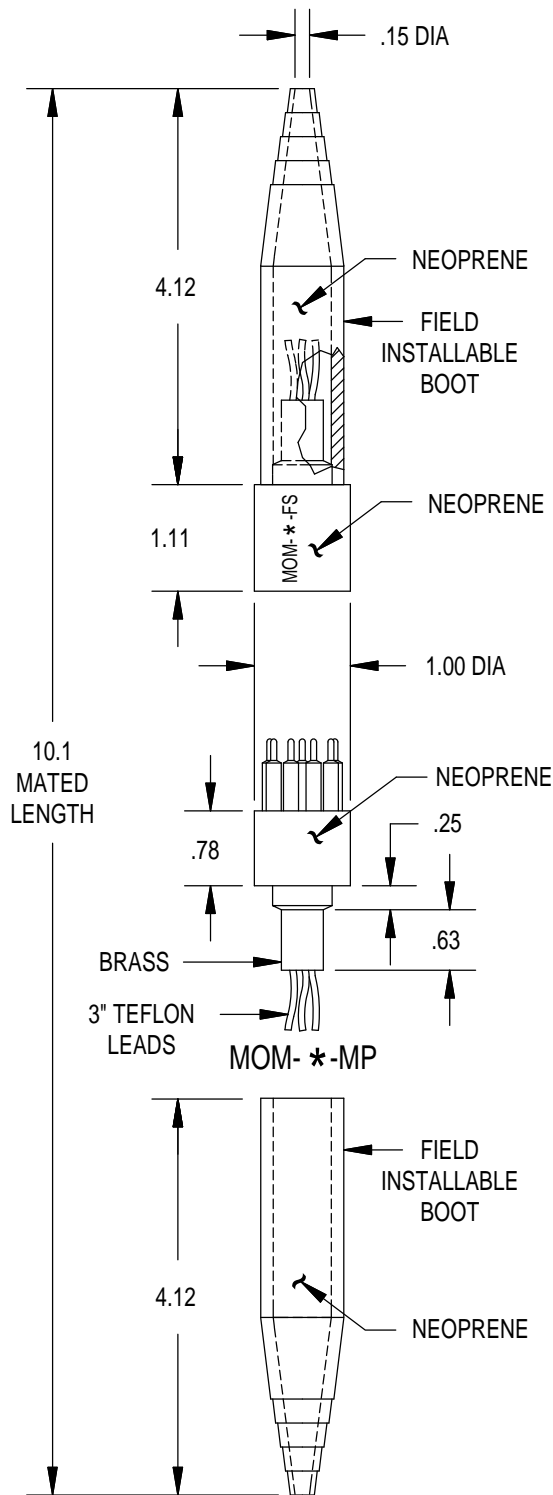

**CONTACT
CONFIGURATION**
(MP FACE VIEW)

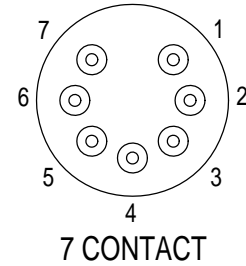
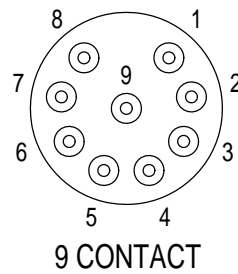

MOUNTING TORQUE FOR MBH-FS/MP	not to exceed 100 in lbs
MATED PRESSURE RATING (psi)	10,000
DUMMY PLUG FOR MBH-FS, MIL-FS, MOM-FS	MDC-*MP
DUMMY PLUG FOR MBH-MP, MIL-MP, MOM-MP	MDC-*FS
<p>NOTE: Delrin locking sleeves available (DLSA-M or F). * Specify number of contacts. * Dummy plugs found on page 65 97</p>	

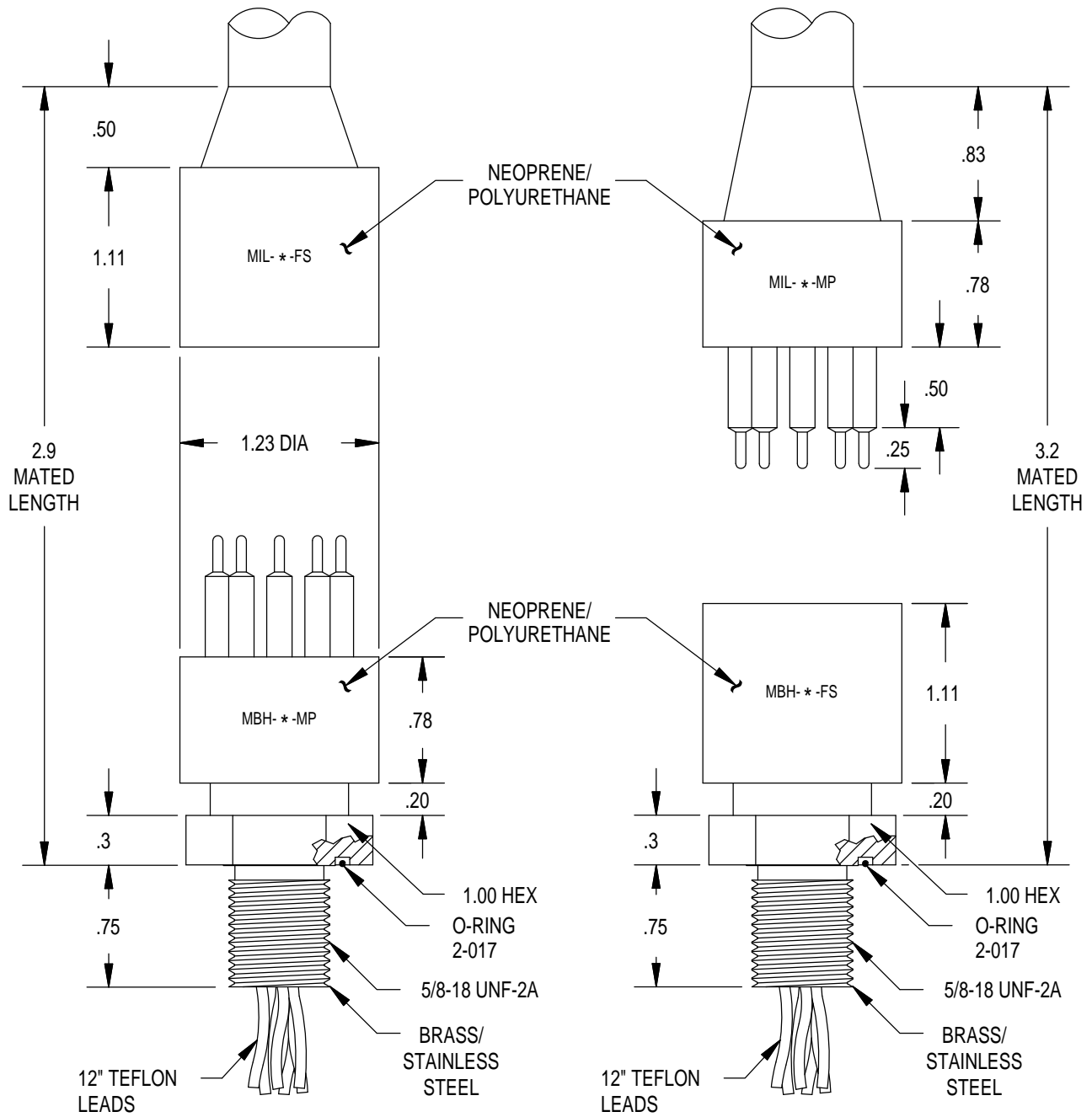

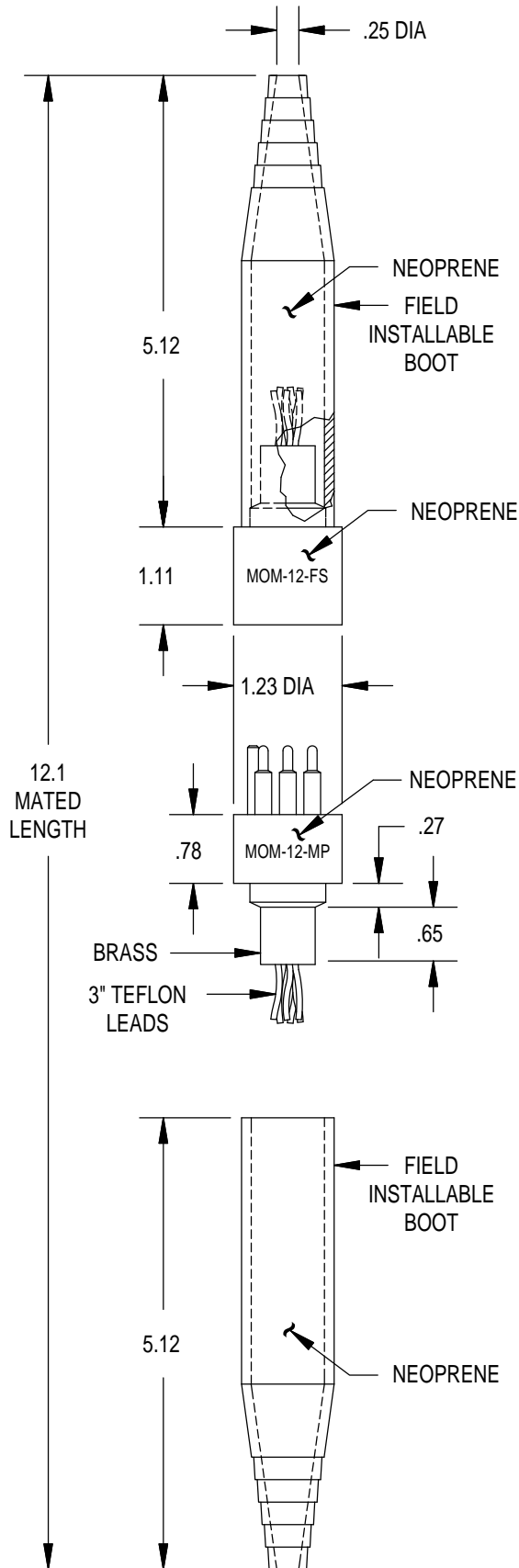

**CONTACT
CONFIGURATION
(MP FACE VIEW)**

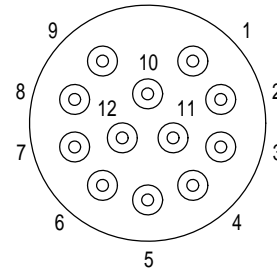

12 CONTACT

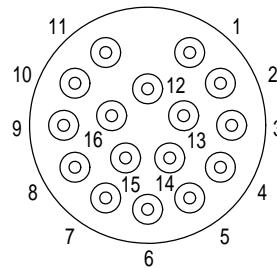

**16 CONTACT
(MOM NOT AVAILABLE)**

MOUNTING TORQUE FOR MBH-FS/MP	not to exceed 100 in lbs
MATED PRESSURE RATING (psi)	10,000
DUMMY PLUG FOR MBH-FS, MIL-FS, MOM-FS	MDC-* -MP
DUMMY PLUG FOR MBH-MP, MIL-MP, MOM-MP	MDC-* -FS
NOTE: Delrin locking sleeves available (DLSB-M or F). * Specify number of contacts. * Dummy plugs found on page 65 97	

CONTACT
CONFIGURATION
(MP FACE VIEW)

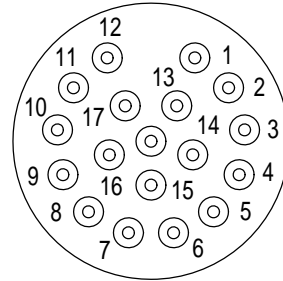

18 CONTACT

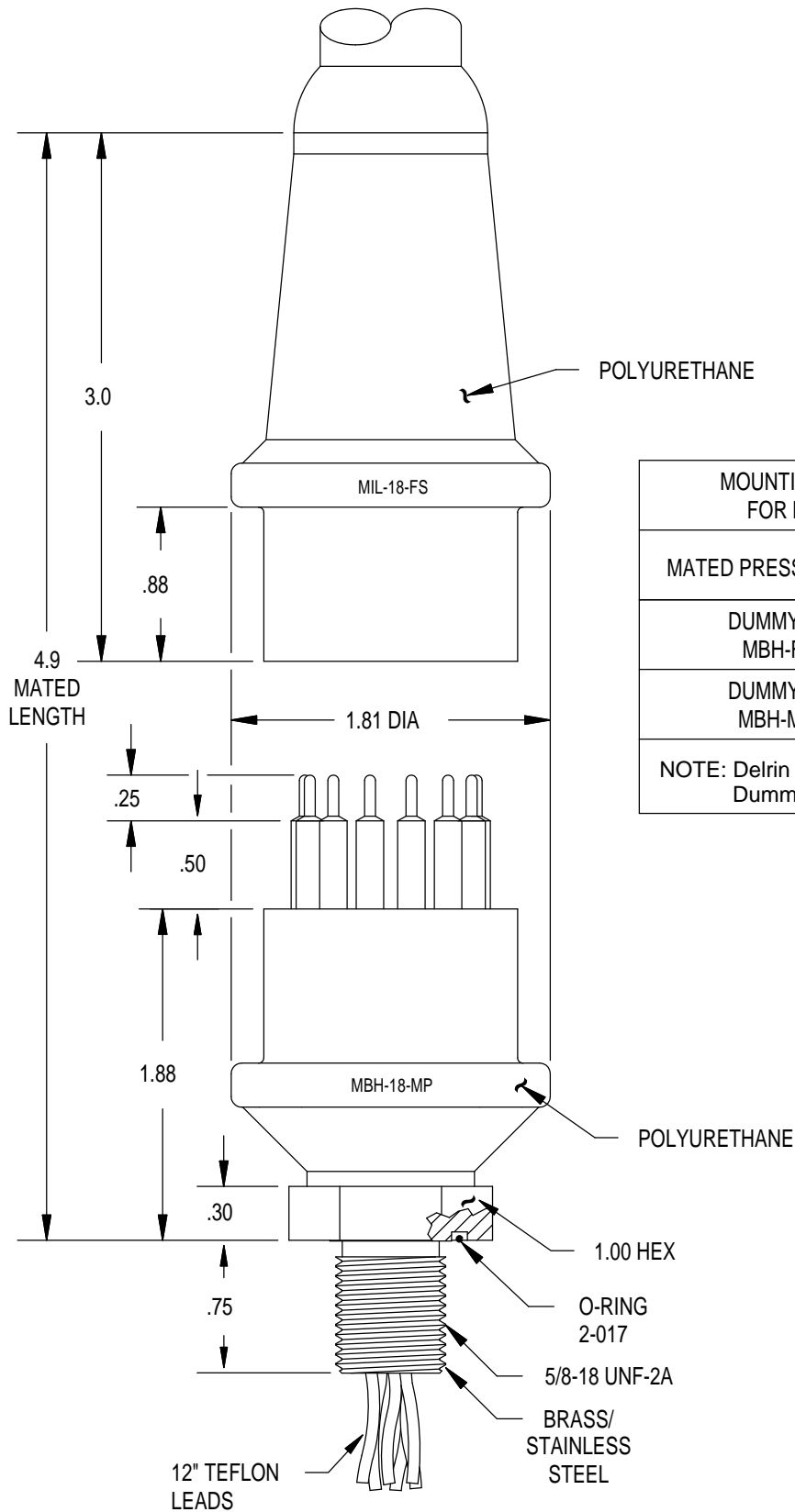

MOUNTING TORQUE FOR BH-FS/MP	not to exceed 100 in lbs
MATED PRESSURE RATING (psi)	10,000
DUMMY PLUG FOR MBH-FS, MIL-FS	MDC-18-MP
DUMMY PLUG FOR MBH-MP, MIL-MP	MDC-18-FS
NOTE: Delrin locking sleeve available (DLSD-M or F). Dummy plugs found on page 65 98	

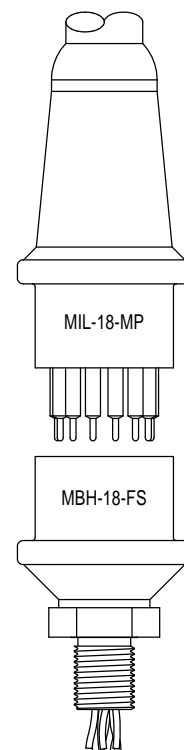

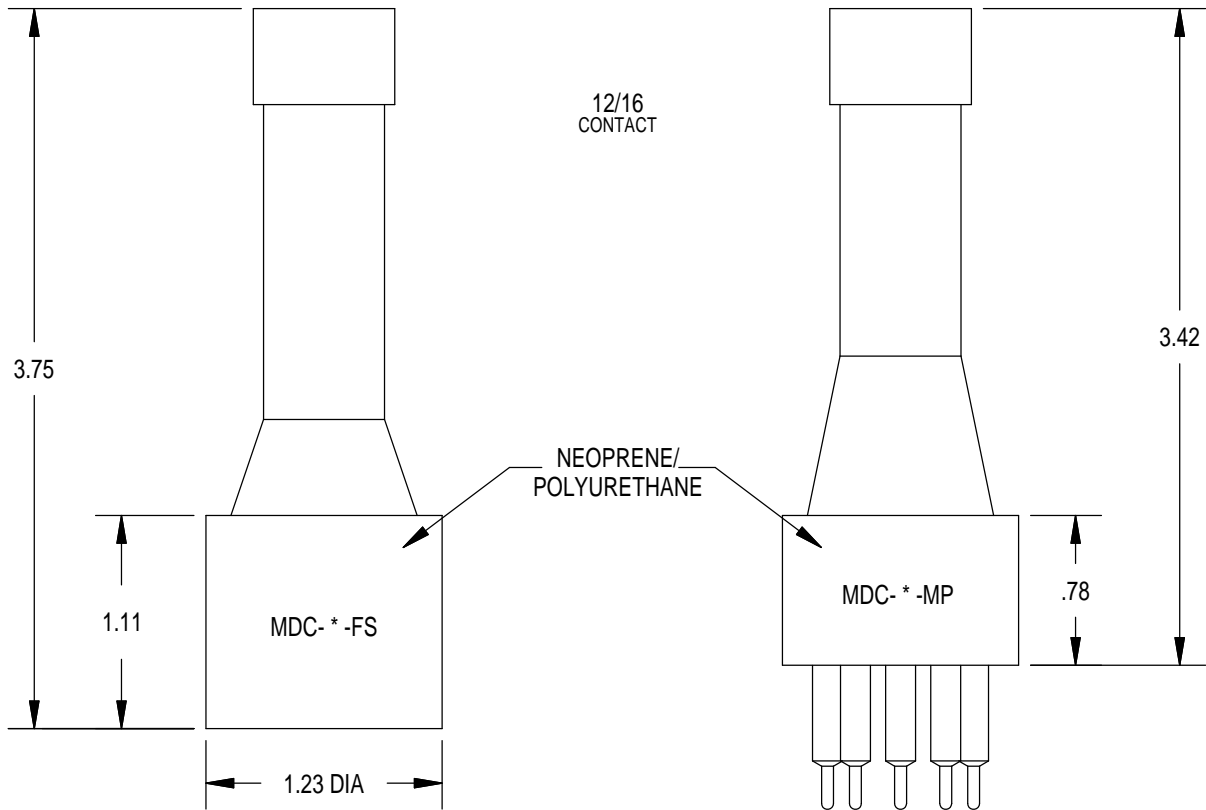
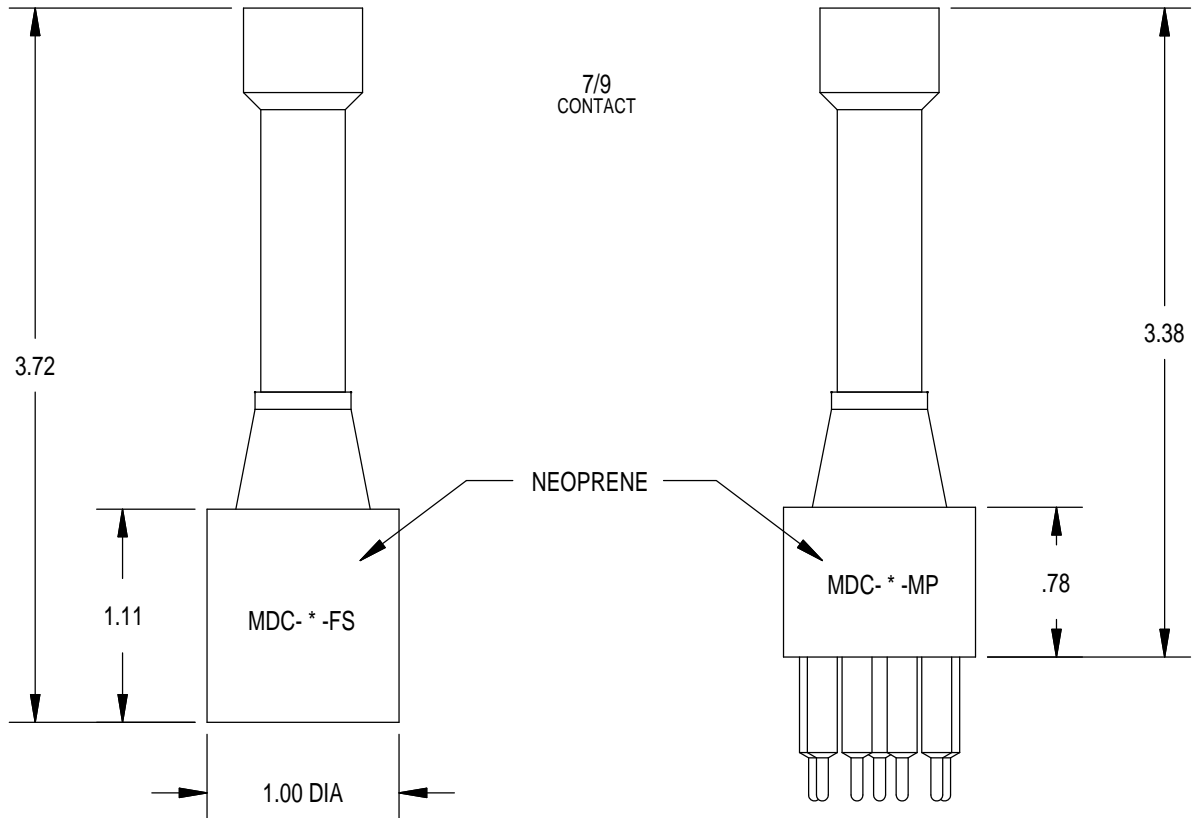

*Specify number of contacts

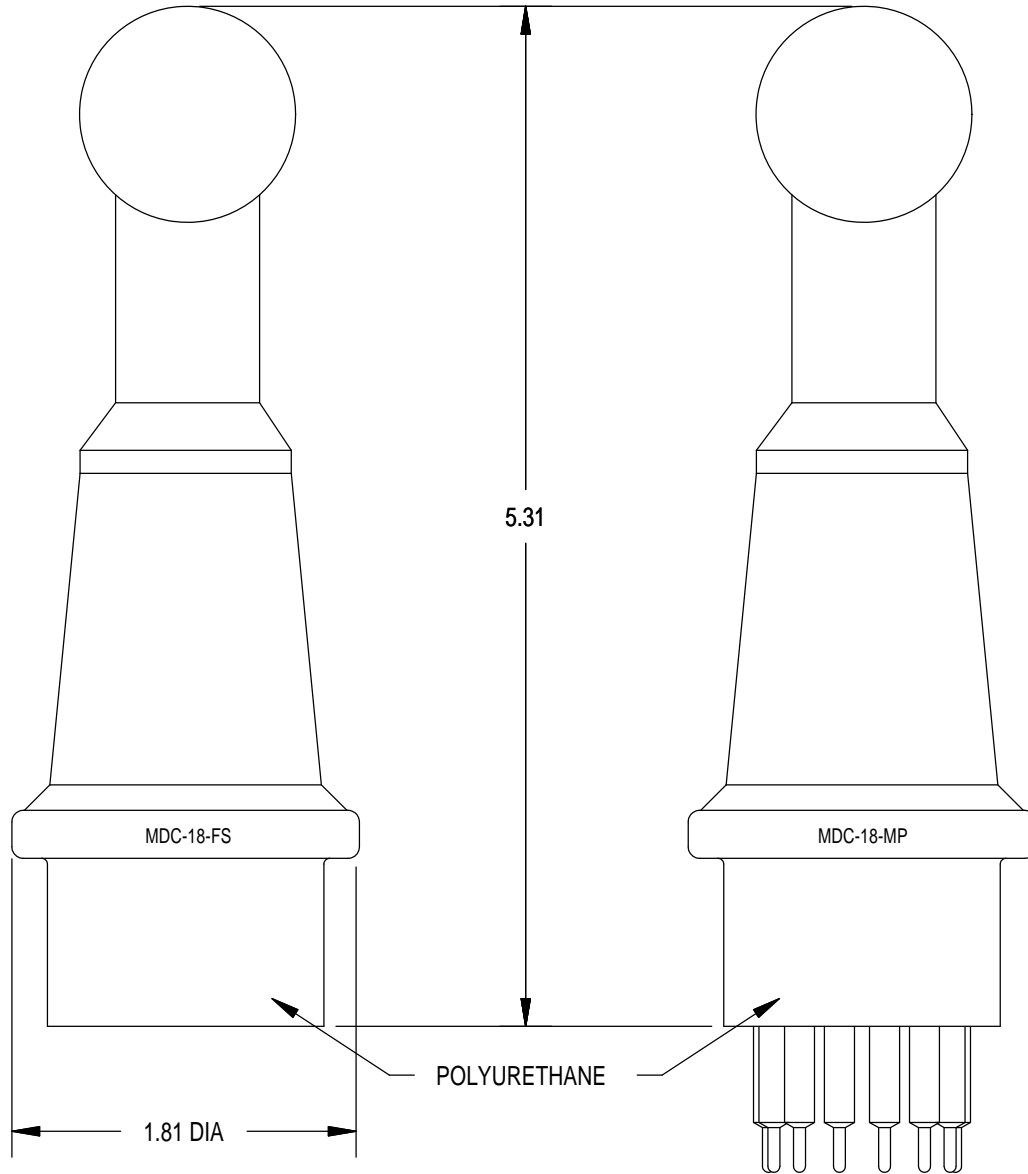

DELTRIN LOCKING SLEEVES

MALE

DLSD-M

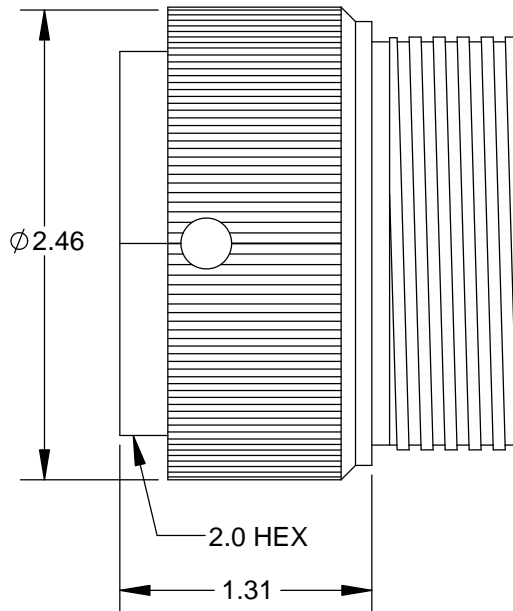

FEMALE

DLSD-F

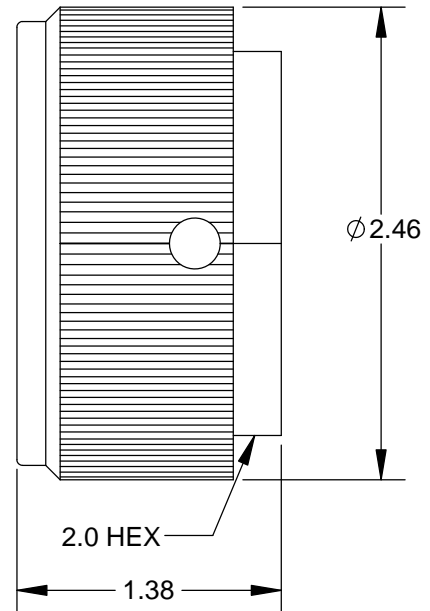

LOCKING SLEEVES FOR:
MBH/MIL-18-FS/MP

HDBH-2/4

GEOPHYSICAL CONNECTORS

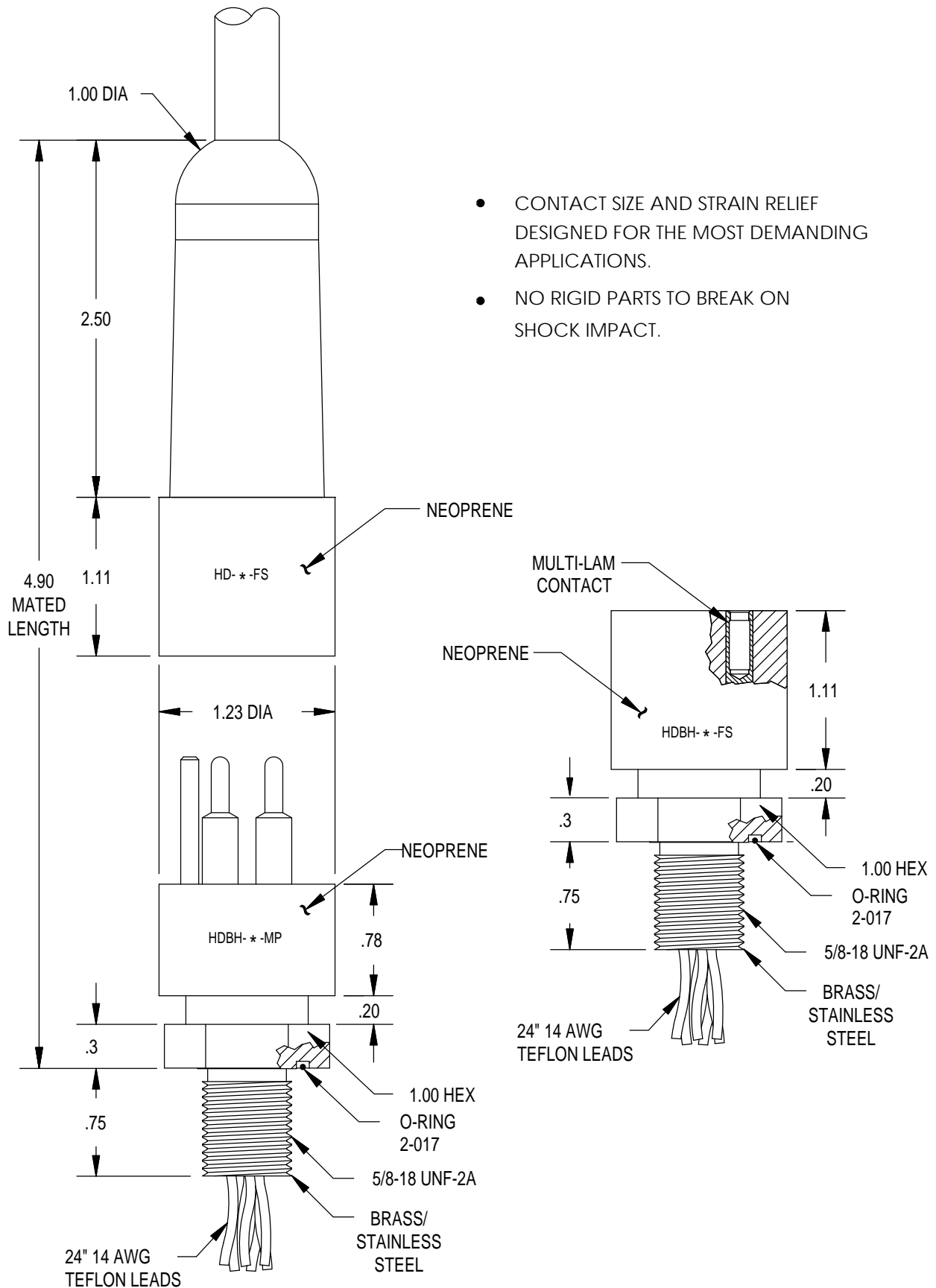

- CONTACT SIZE AND STRAIN RELIEF DESIGNED FOR THE MOST DEMANDING APPLICATIONS.
- NO RIGID PARTS TO BREAK ON SHOCK IMPACT.

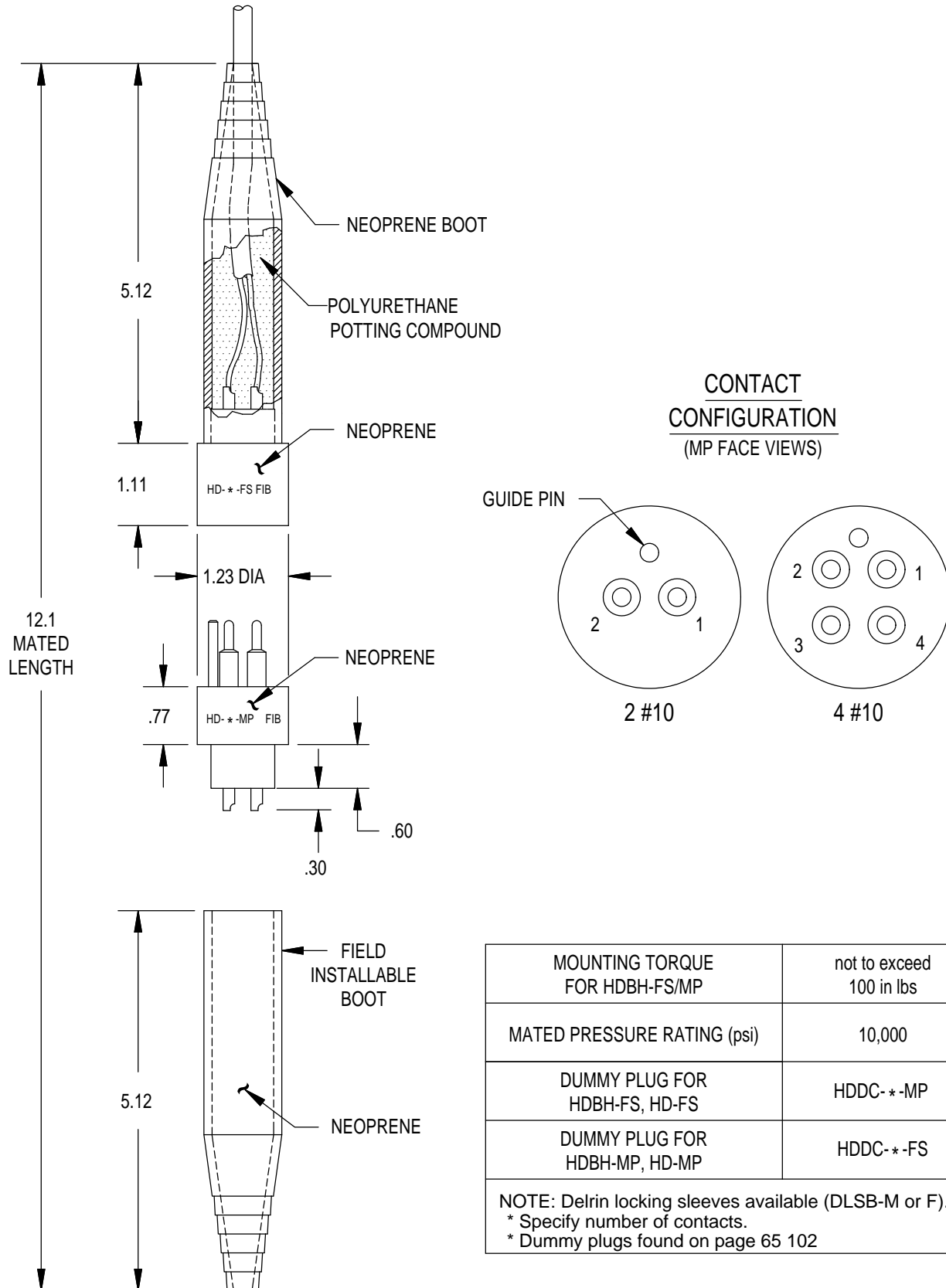

MOUNTING TORQUE FOR HDBH-FS/MP	not to exceed 100 in lbs
MATED PRESSURE RATING (psi)	10,000
DUMMY PLUG FOR HDBH-FS, HD-FS	HDDC-* -MP
DUMMY PLUG FOR HDBH-MP, HD-MP	HDDC-* -FS
<p>NOTE: Delrin locking sleeves available (DLSB-M or F). * Specify number of contacts. * Dummy plugs found on page 65 102</p>	

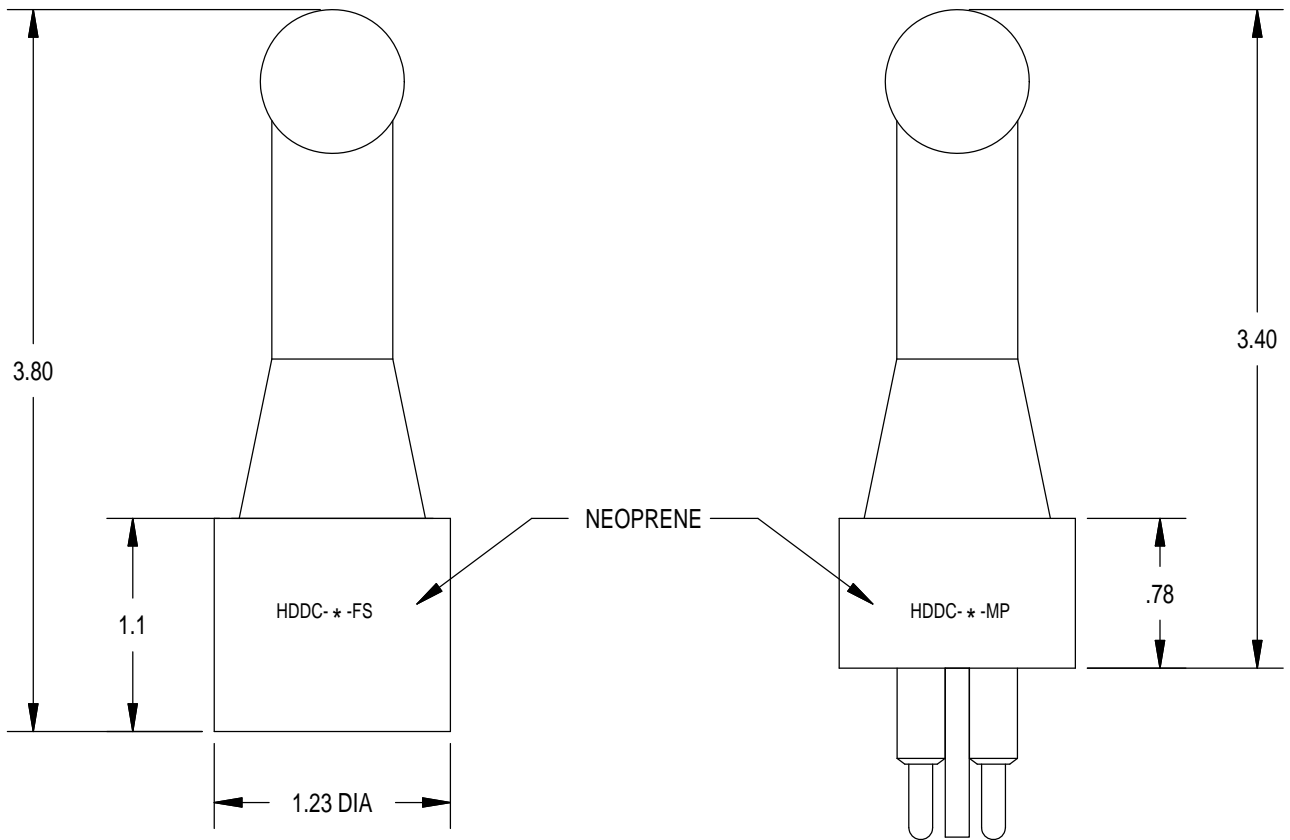

*Specify number of contacts

DESCRIPTION AND MATERIAL	<ul style="list-style-type: none">• Molded neoprene or polyurethane.• Two to eight contacts.• Up to 750 VDC.• Up to 10,000 PSI, mated.• Bulkhead connector design open face pressure rated to 5000 PSI.• Contacts gold plated per MIL-G-45204.
CABLE	<ul style="list-style-type: none">• Inline connectors in this series are molded on a standard 24" length of cable, 20 AWG, unless otherwise specified.• Bulkhead connectors have 12" teflon leads, Type E per MIL 16878/4, 20 AWG, (2-4, 9-18 contact) or 22 AWG (5-8 contact).• MCOM connectors have 12" teflon leads, Type E per MIL 16878/4, 20 AWG (2-4 contact) or 22 AWG (5-8 contact)
USES	<ul style="list-style-type: none">• Light to medium duty applications.• Hazardous environments.
GUIDELINES	<ul style="list-style-type: none">• All mounting surfaces require a 32 finish.• Lubricate mating surface with 3M Silicone Spray or equivalent, DO NOT grease! Connectors must be lubricated on a regular basis.• Lubricate o-ring with Dow Corning #111 Valve Lubricant or equivalent.• Replace o-rings when re-using connectors.• Avoid nicks and cuts around contacts as these are the sealing surfaces.• Elastomers can be seriously degraded if exposed to direct sunlight or high ozone levels for extended periods of time.• Do not over tighten bulkhead nuts.• Grip main body of connector during mating or unmating. Do not pull on cable to disconnect.• Avoid sharp bends at cable entry to connector.
ORDERING INFORMATION	<ul style="list-style-type: none">• Bulkhead connectors do not come with nuts and washers. Nuts and washers should be ordered separately.

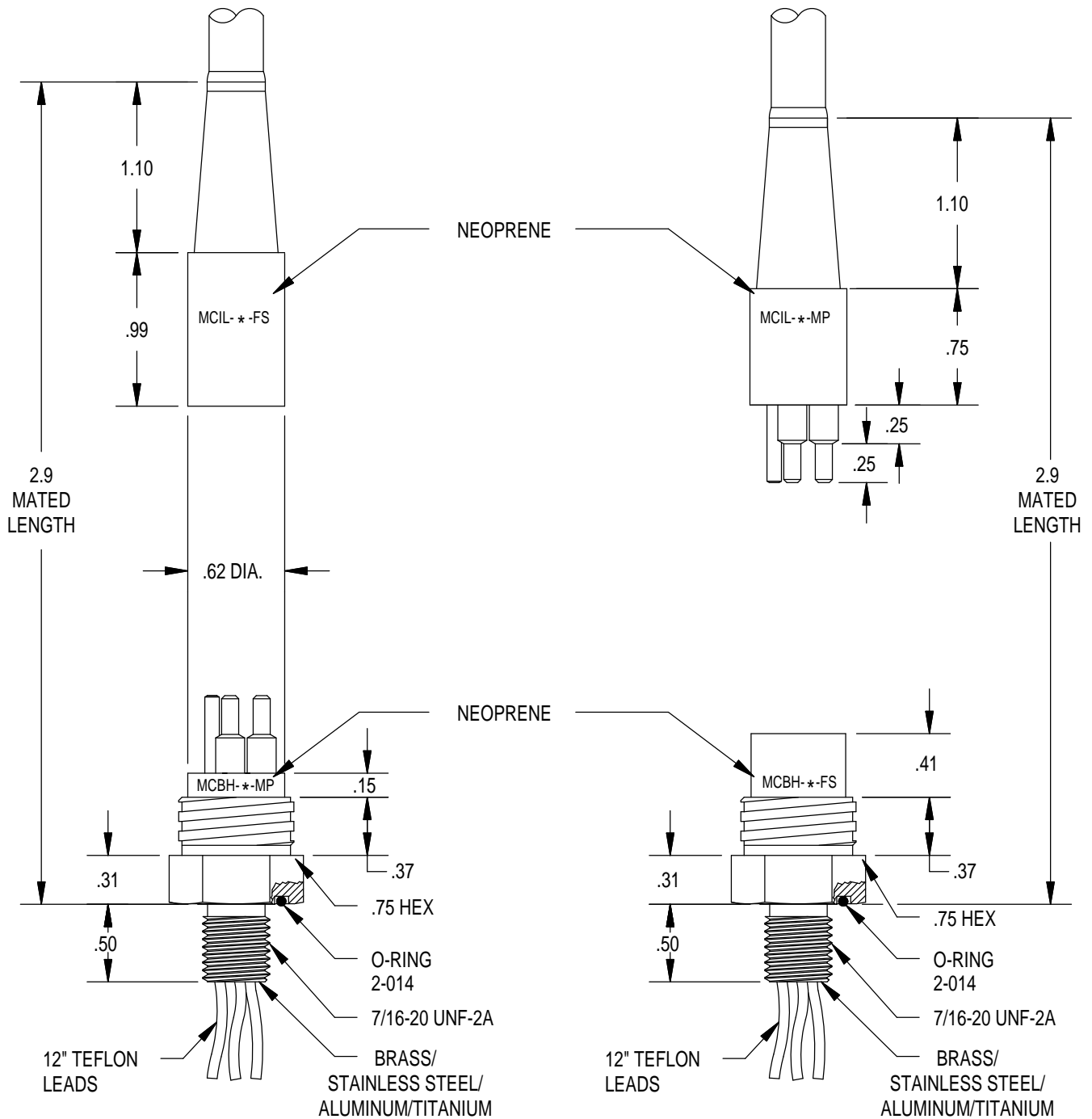

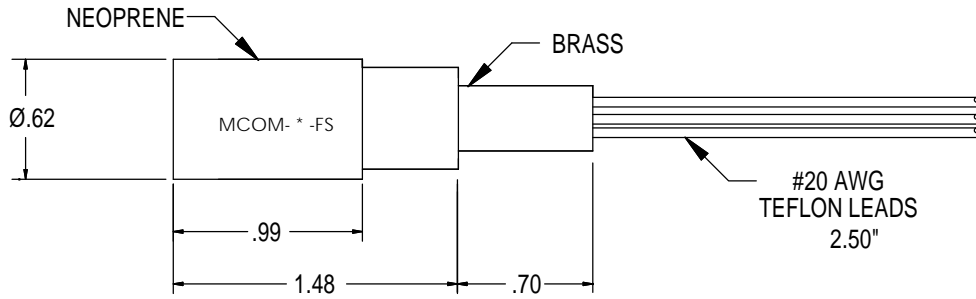
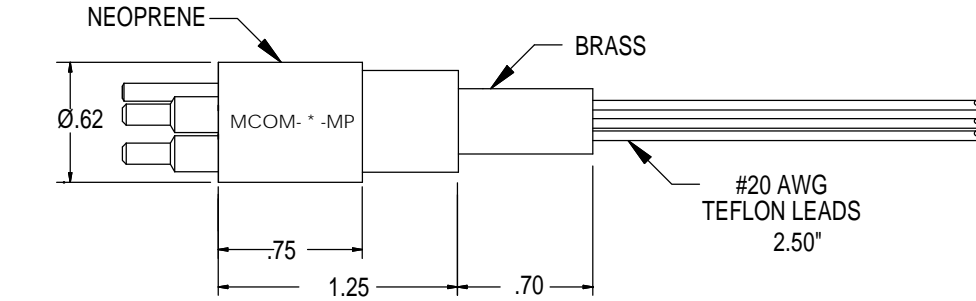

MALE
MCDLS-M

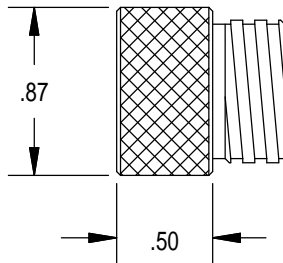

FEMALE
MCDLS-F

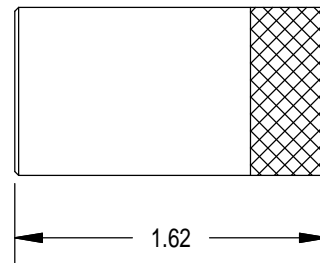

CONTACT
CONFIGURATION
(MP FACE VIEW)

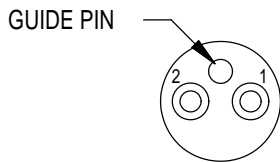

2 #12
W/ GUIDE PIN

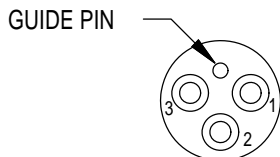

3 #12
W/ GUIDE PIN

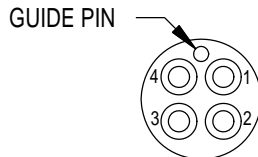

4 #12
W/ GUIDE PIN

MOUNTING TORQUE FOR MCBH-FS/MP	not to exceed 100 in lbs
MATED PRESSURE RATING (psi)	10,000
DUMMY PLUG FOR MCIL/BH-FS	MCDC- * -MP
DUMMY PLUG FOR MCIL/BH-MP	MCDC- * -FS
* Specify number of contacts.	
NOTE: Bulkhead body available in Titanium. Standard 3/4" thread length.	

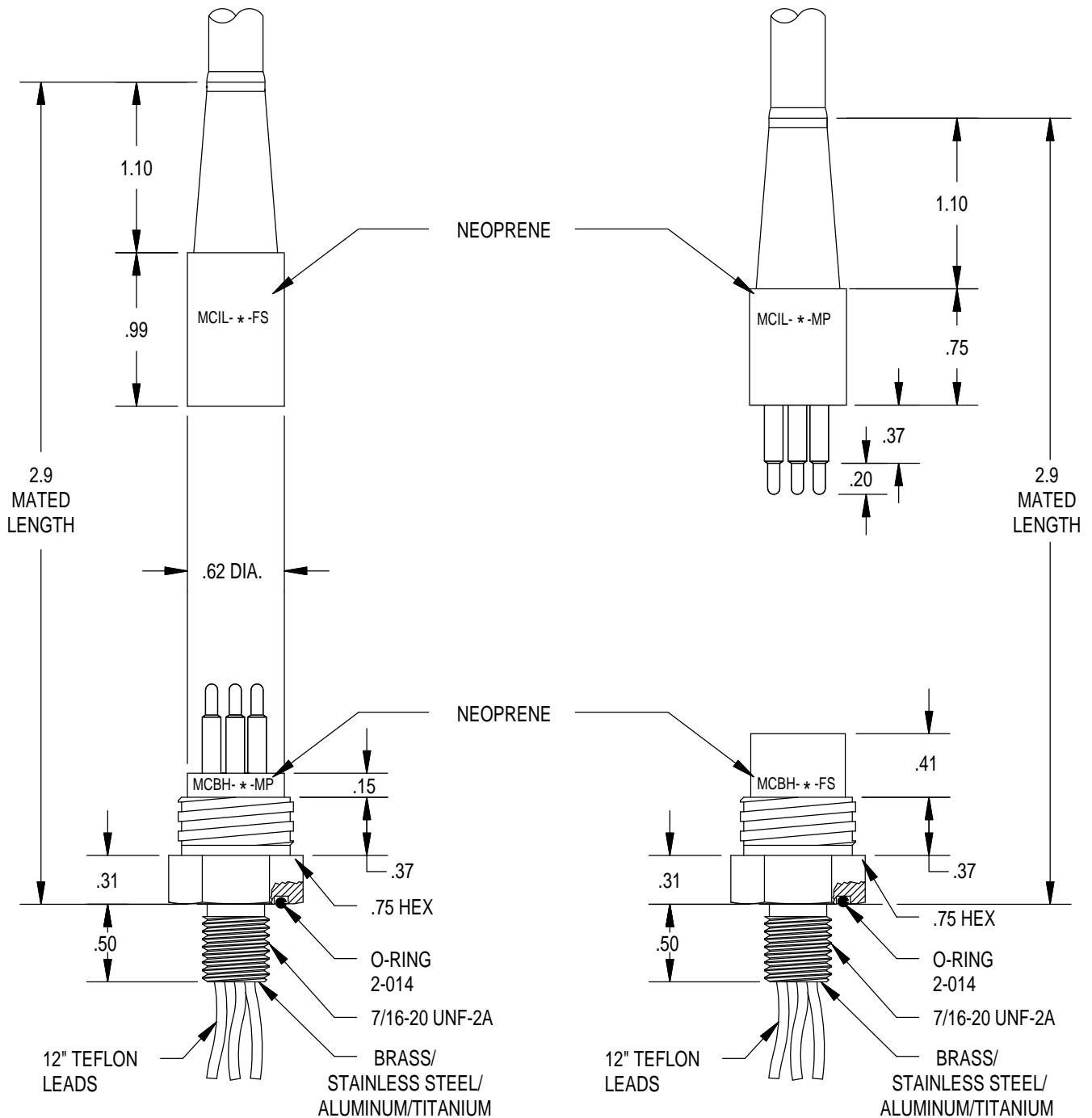

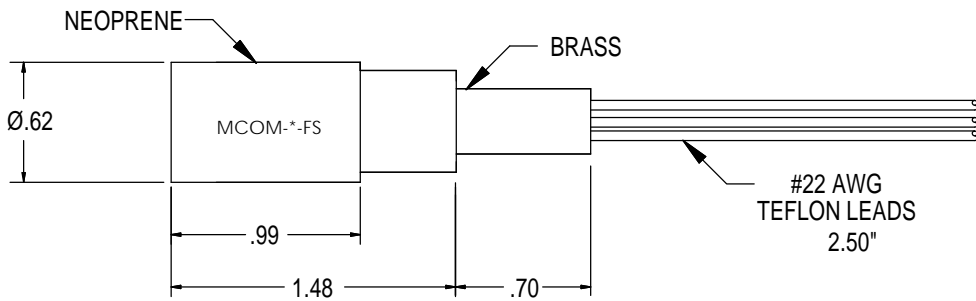
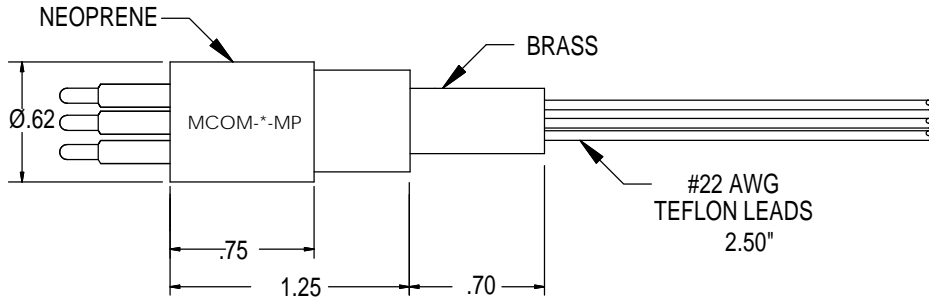

MALE
MCDLS-M

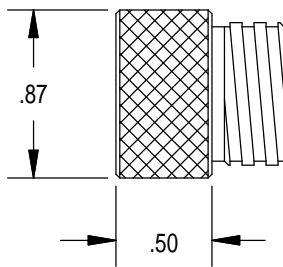

FEMALE
MCDLS-F

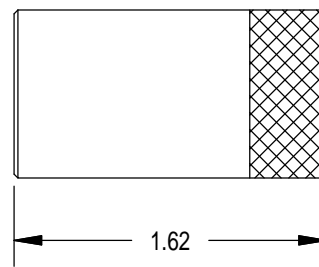

CONTACT
CONFIGURATION
(MP FACE VIEW)

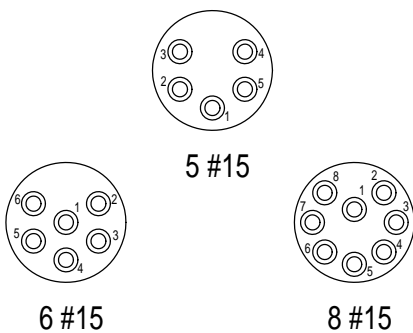

MOUNTING TORQUE FOR MCBH-FS/MP	not to exceed 100 in lbs
MATED PRESSURE RATING (psi)	10,000
DUMMY PLUG FOR MCIL/BH-FS	MCDC- * -MP
DUMMY PLUG FOR MCIL/BH-MP	MCDC- * -FS
* Specify number of contacts.	
NOTE: Bulkhead body available in Titanium. Standard 3/4" thread length.	

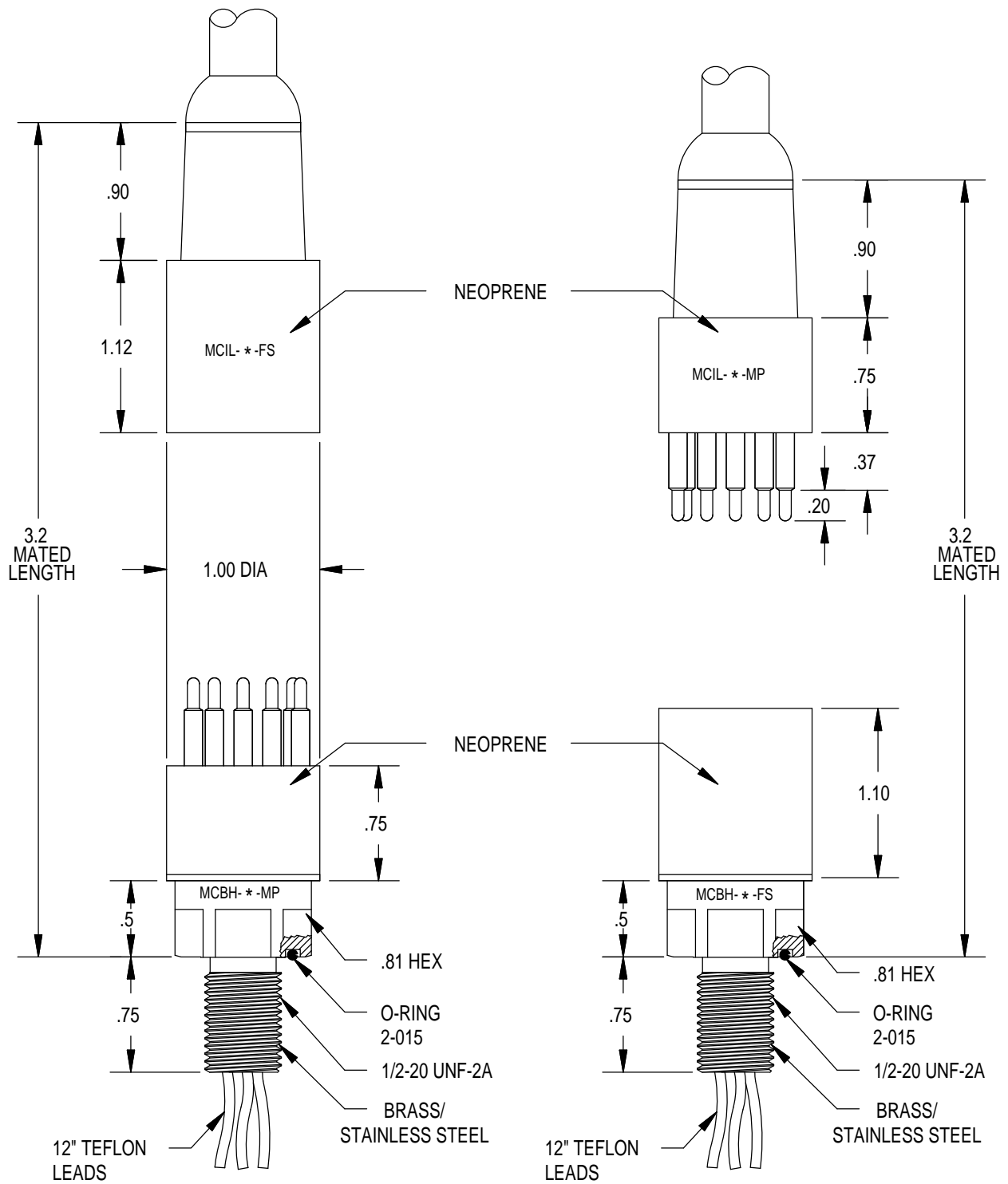

MALE

FEMALE

DLSA-M

DLSA-F

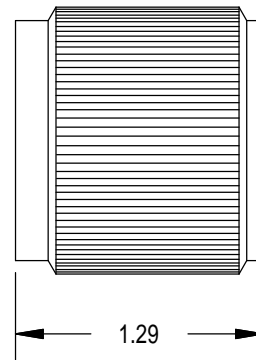
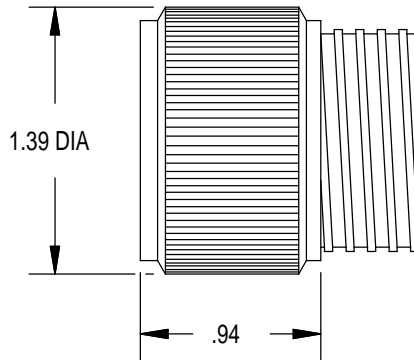

CONTACT
CONFIGURATION
(MP FACE VIEW)

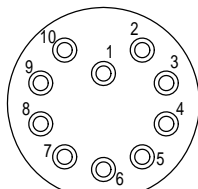

10 #15

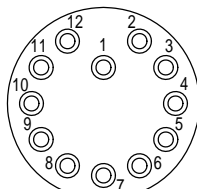

12 #15

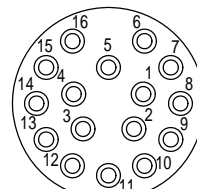

16 #15

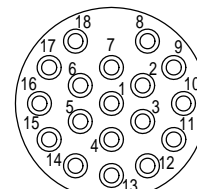

18 #15

MOUNTING TORQUE FOR MCBH-FS/MP	not to exceed 100 in lbs
MATED PRESSURE RATING (psi)	10,000
DUMMY PLUG FOR MCIL/BH-FS	MCDC- * -MP
DUMMY PLUG FOR MCIL/BH-MP	MCDC- * -FS
* Specify number of contacts. * Dummy plugs found on page 65 126	
NOTE: Bulkhead body available in Titanium. Standard 3/4" thread length.	

LPMCBH/LPMCIL-9

MICRO MINI WET
PLUGGABLE SERIES

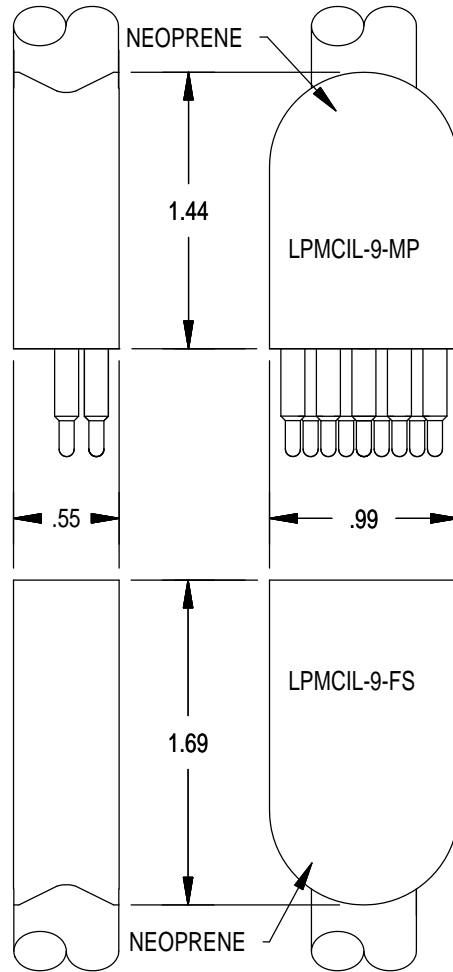
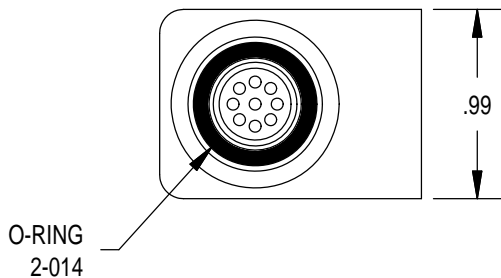
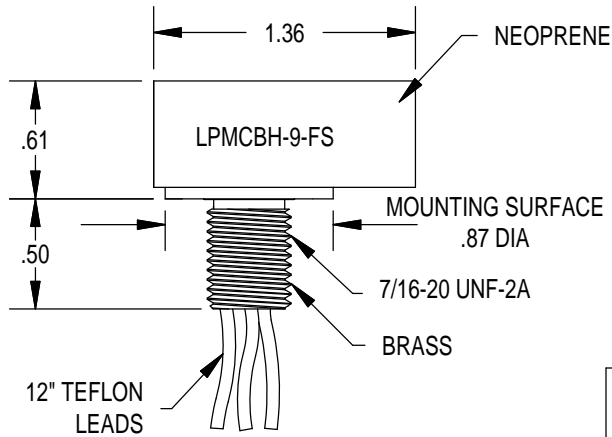
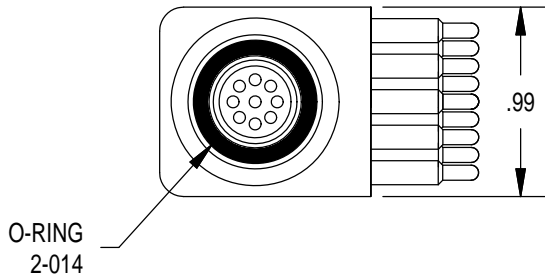
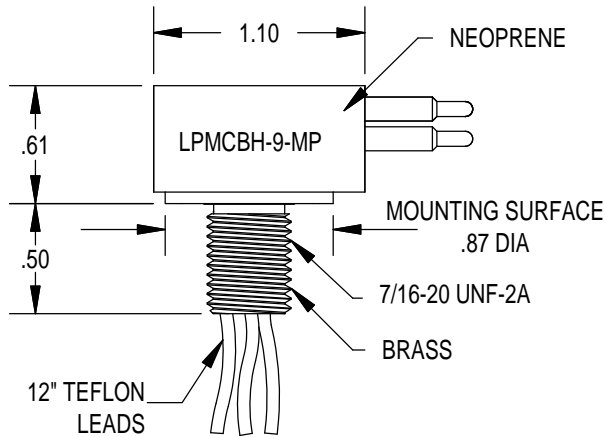

CONTACT CONFIGURATION (MP FACE VIEW)

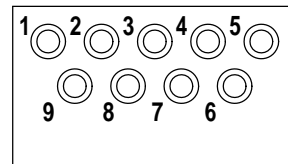

MOUNTING TORQUE FOR LPMCBH-FS/MP	not to exceed 100 in/lbs
MATED PRESSURE RATING (psi)	10,000
DUMMY PLUG FOR LPMCIL/BH-FS	LPMCDC- *-MP
DUMMY PLUG FOR LPMCIL/BH-MP	LPMCDC- *-FS
NOTE: Bulkhead body available in Stainless Steel. Standard 1/2" thread length. Dummy plugs found on page 65 127	

MCDC-2/3/4/5/6/8

MICRO MINI WET PLUGGABLE SERIES

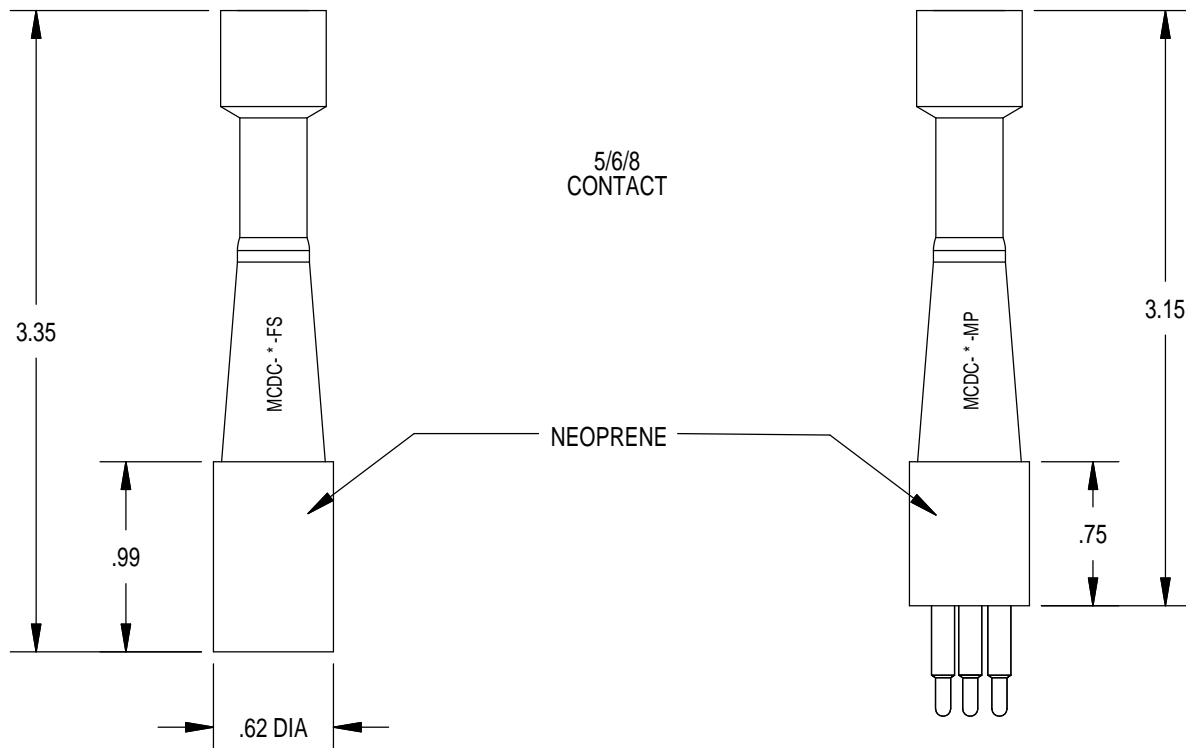
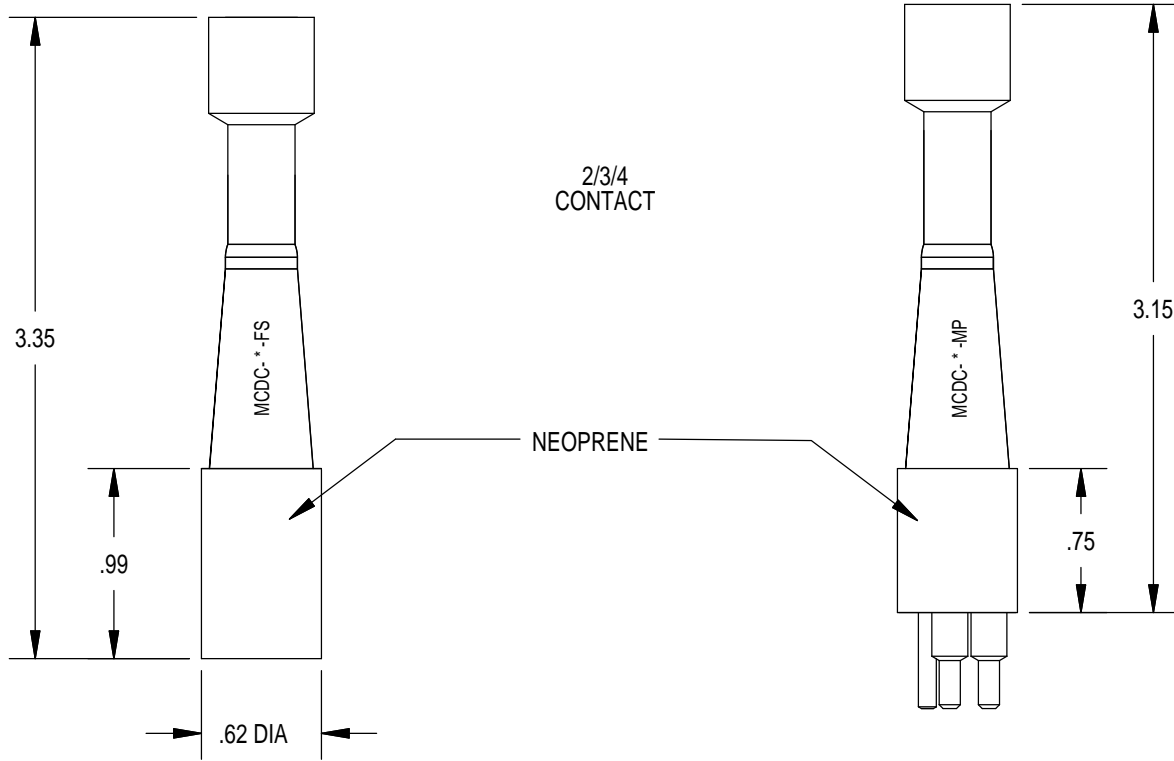

* Specify number of contacts

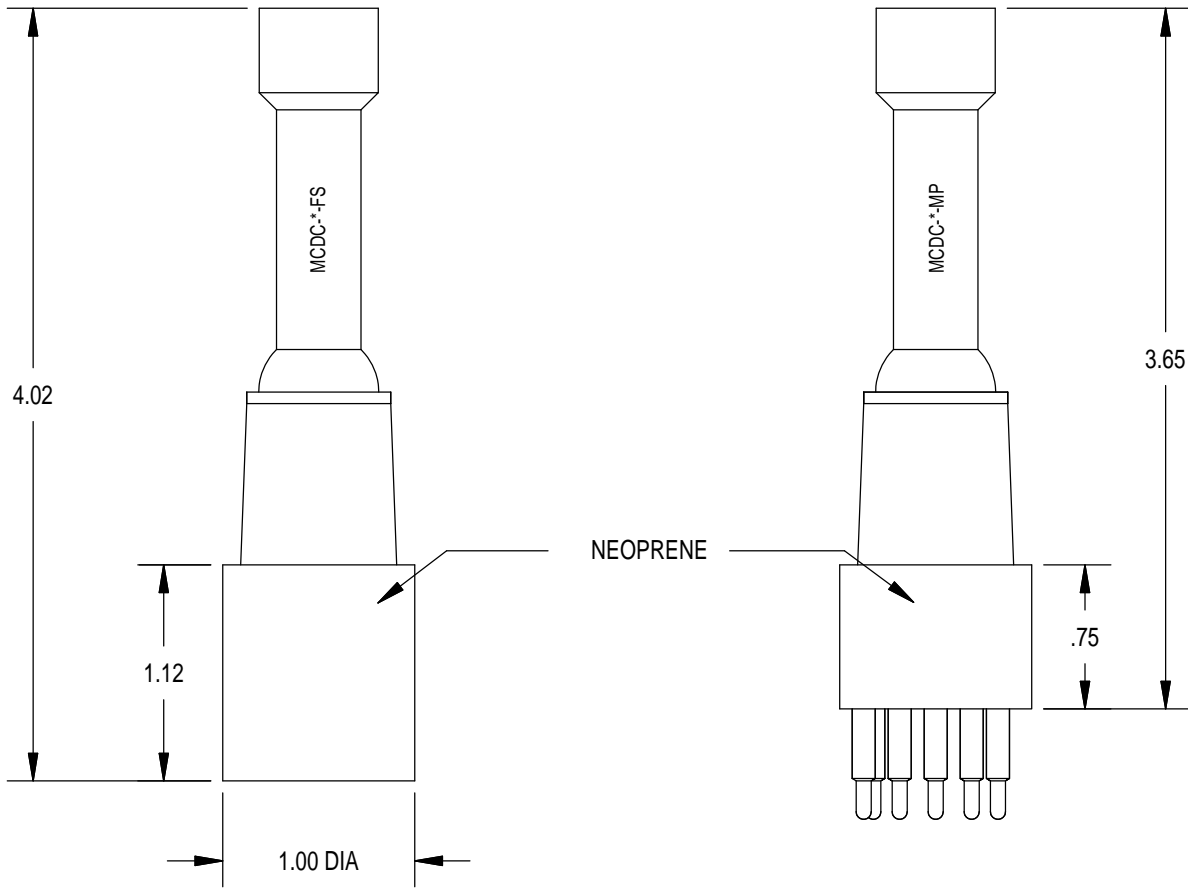

* Specify number of contacts

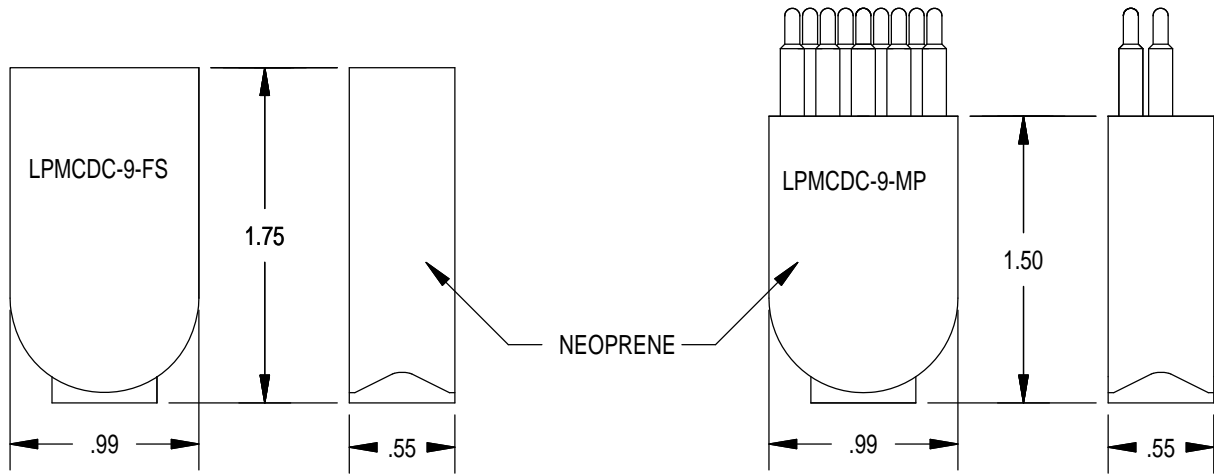

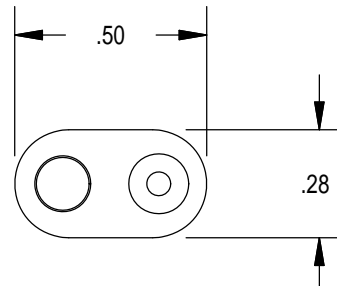
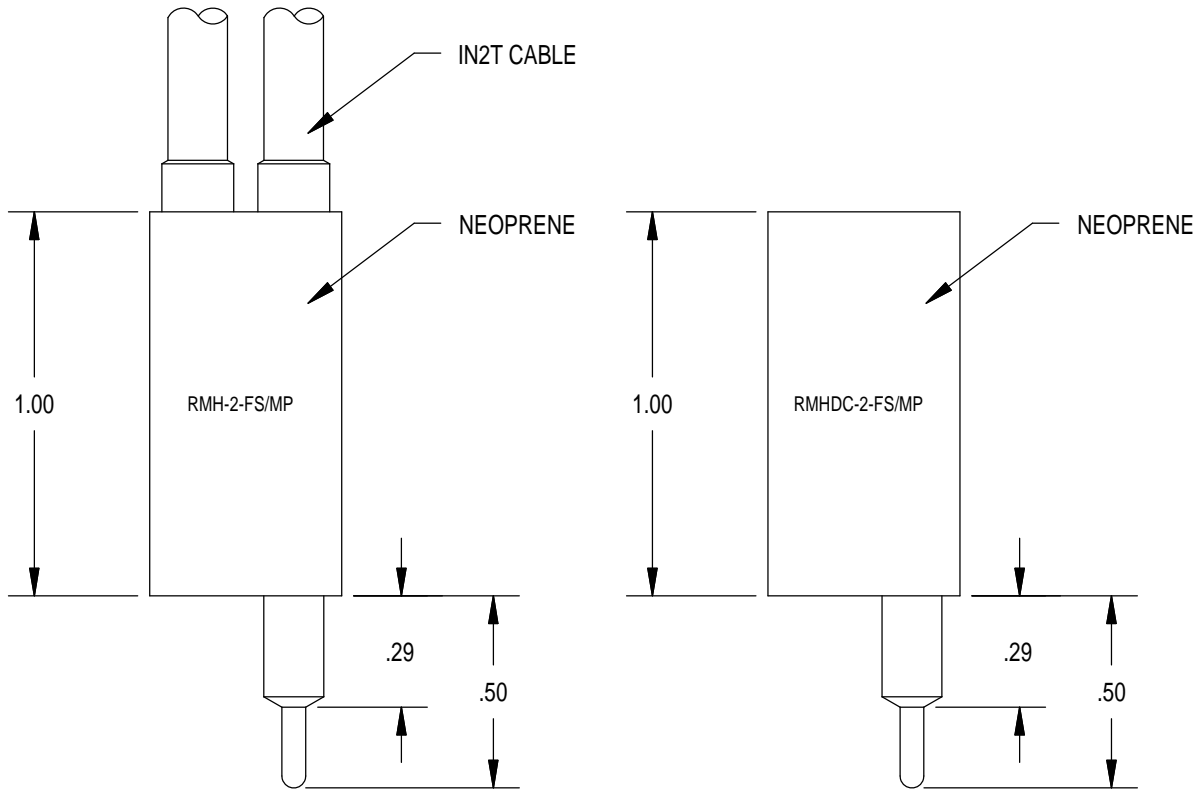

MATED PRESSURE RATING (psi)	10,000
DUMMY PLUG FOR RMH-2-FS/MP	RMHDC-2-FS/MP

DESCRIPTION AND MATERIAL	<ul style="list-style-type: none">• Molded neoprene.• Two to eight contacts.• Up to 600 VDC.• Up to 10,000 PSI, mated.• Glass reinforced epoxy puck with o-ring seal provides waterblock in event of damage to neoprene face of bulkhead.• Bulkhead connector design open face pressure rated to 5000 PSI.• Contacts gold plated per MIL-G-45204.
CABLE	<ul style="list-style-type: none">• Inline connectors in this series are molded on a standard 24" length of cable, #20 AWG, unless otherwise specified.• Bulkhead connectors have 12" teflon leads, Type E per MIL 16878/4, two to four contact - #20 AWG, five to eight contact - #22 AWG.
USES	<ul style="list-style-type: none">• Light to medium duty applications.• Hazardous environments.
GUIDELINES	<ul style="list-style-type: none">• All mounting surfaces require a 32 finish.• Lubricate mating surface with 3M Silicone Spray or equivalent, DO NOT grease! Connectors must be lubricated on a regular basis.• Lubricate o-ring with Dow Corning #111 Valve Lubricant or equivalent.• Replace o-rings when re-using connectors.• Avoid nicks and cuts around contacts as these are the sealing surfaces.• Elastomers can be seriously degraded if exposed to direct sunlight or high ozone levels for extended periods of time.• Do not over tighten bulkhead nuts.• Do not pull on cable to disconnect.• Avoid sharp bends at cable entry to connector.
ORDERING INFORMATION	<ul style="list-style-type: none">• Bulkhead connectors do not come with nuts and washers. Nuts and washers should be ordered separately.

MCIL/BH (WB)-2/3/4

MICRO MINI WET
PLUGGABLE (WATERBLOCKED) SERIES

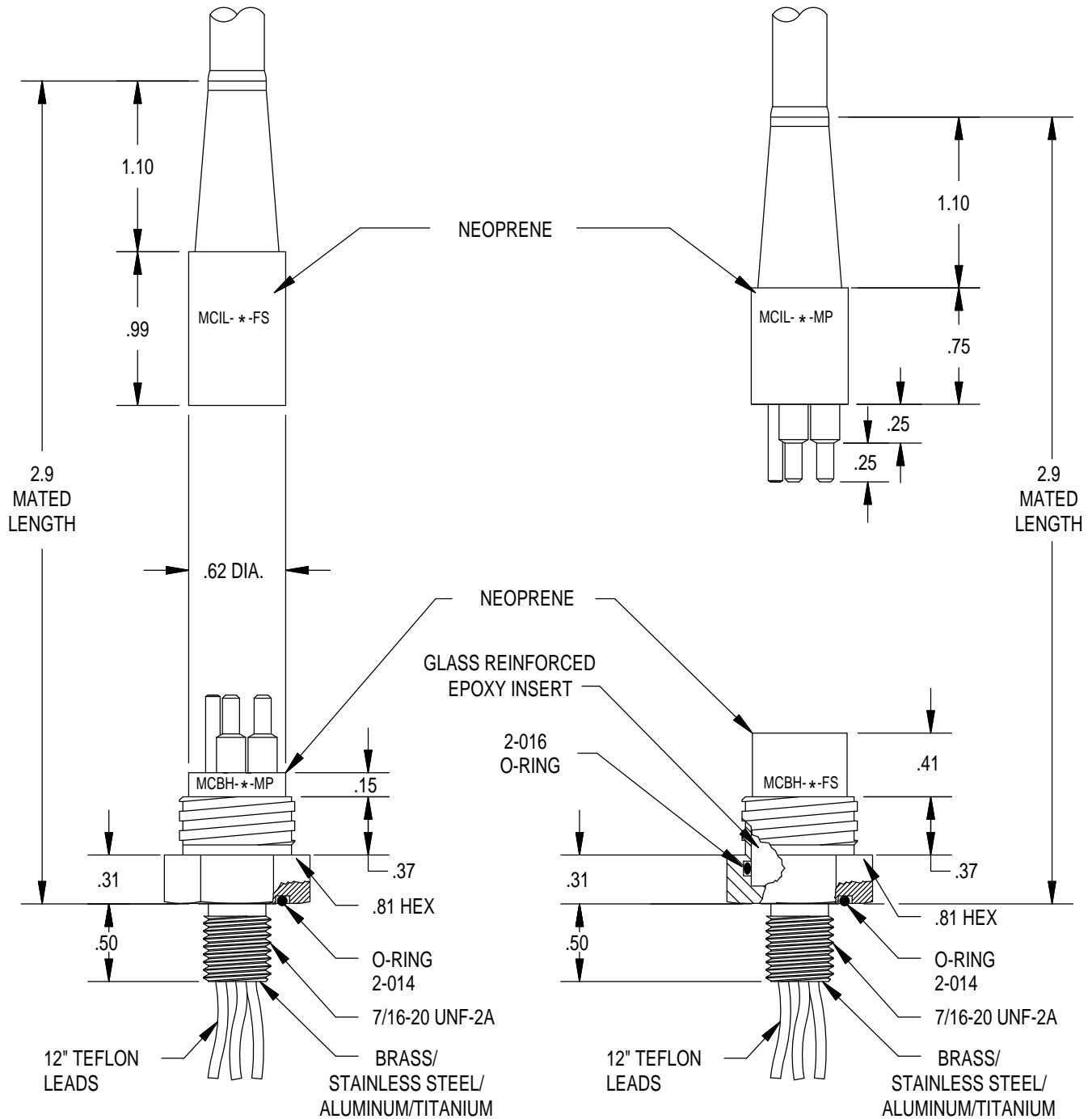

MCIL/BH (WB)-2/3/4-R/A

MICRO MINI WET
PLUGGABLE (WATERBLOCKED) SERIES

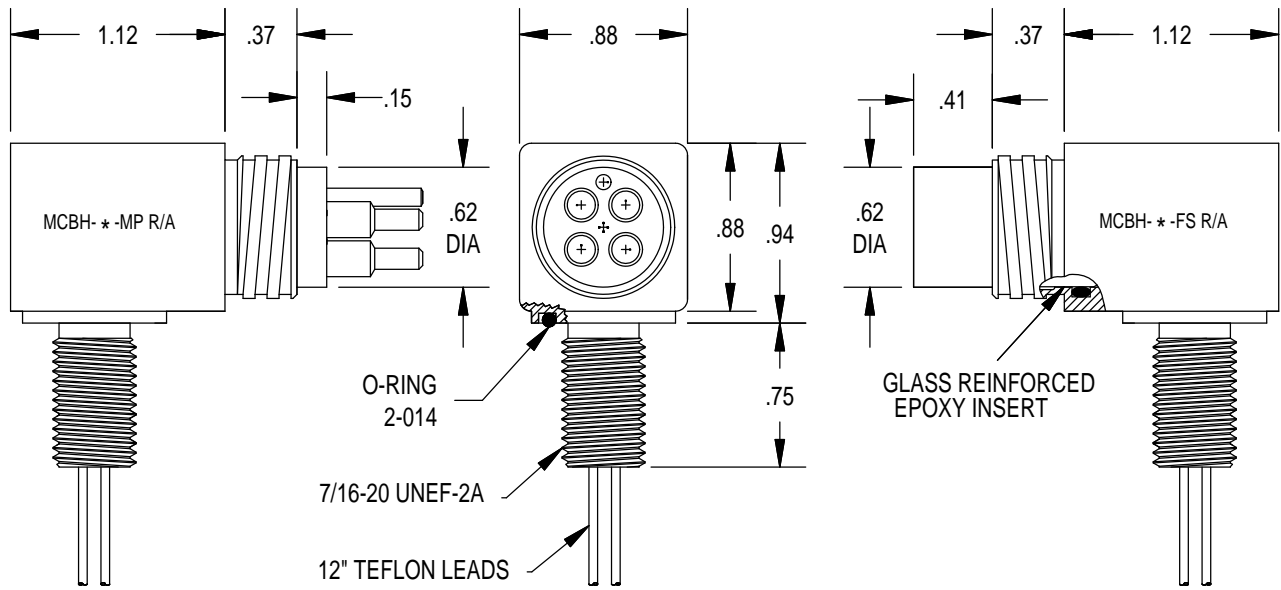

DELTRIN LOCKING SLEEVES

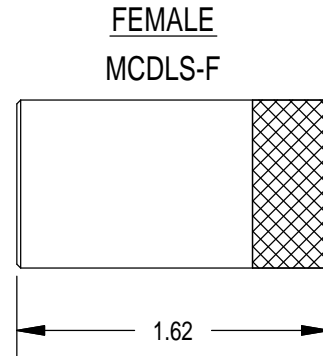
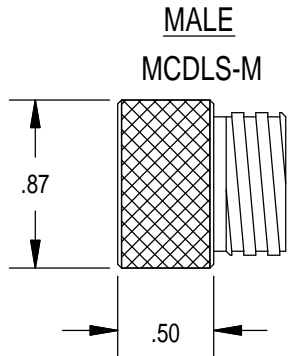

MOUNTING TORQUE FOR MCIL/BH (WB)-FS/MP	not to exceed 100 in/lbs
MATED PRESSURE RATING (psi)	10,000
DUMMY PLUG FOR MCIL/BH (WB)-FS	MCDC- * -MP
DUMMY PLUG FOR MCIL/BH (WB)-MP	MCDC- * -FS
* Specify number of contacts.	
* Dummy plugs found on page 65 125	

CONTACT CONFIGURATION (MP FACE VIEW)

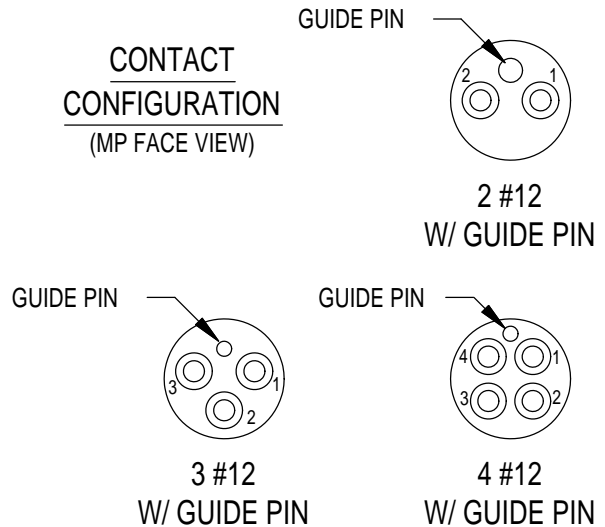

MCIL/BH (WB)-5/6/8

MICRO MINI WET
PLUGGABLE (WATERBLOCKED) SERIES

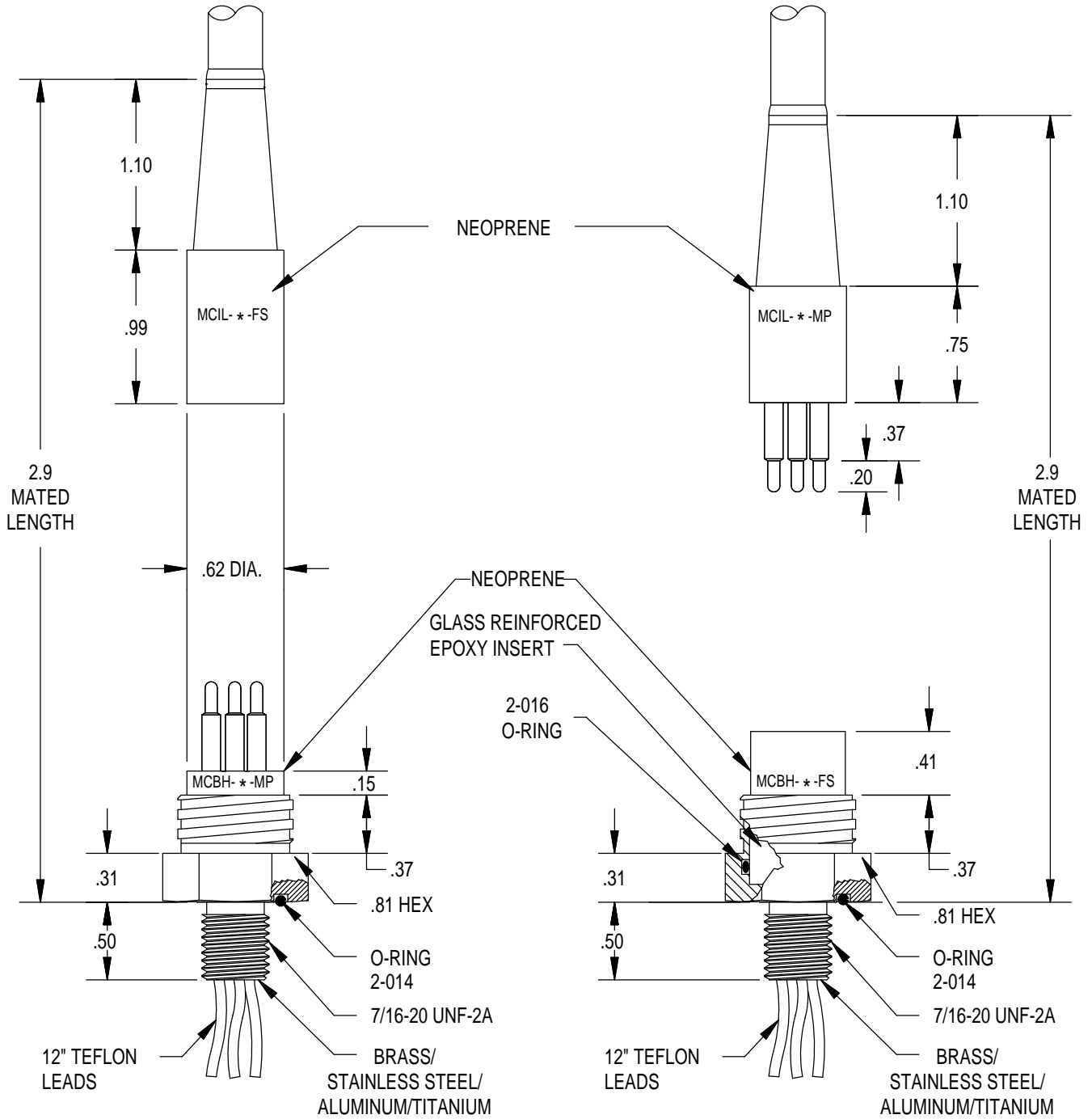

MCIL/BH (WB)-5/6/8

MICRO MINI WET PLUGGABLE (WATERBLOCKED) SERIES

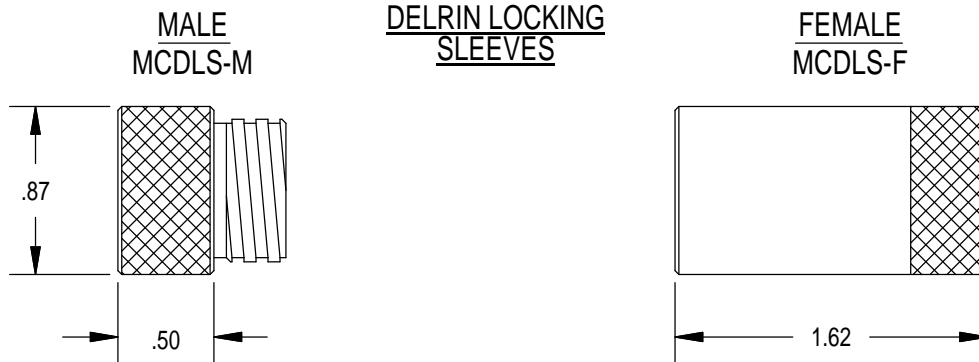
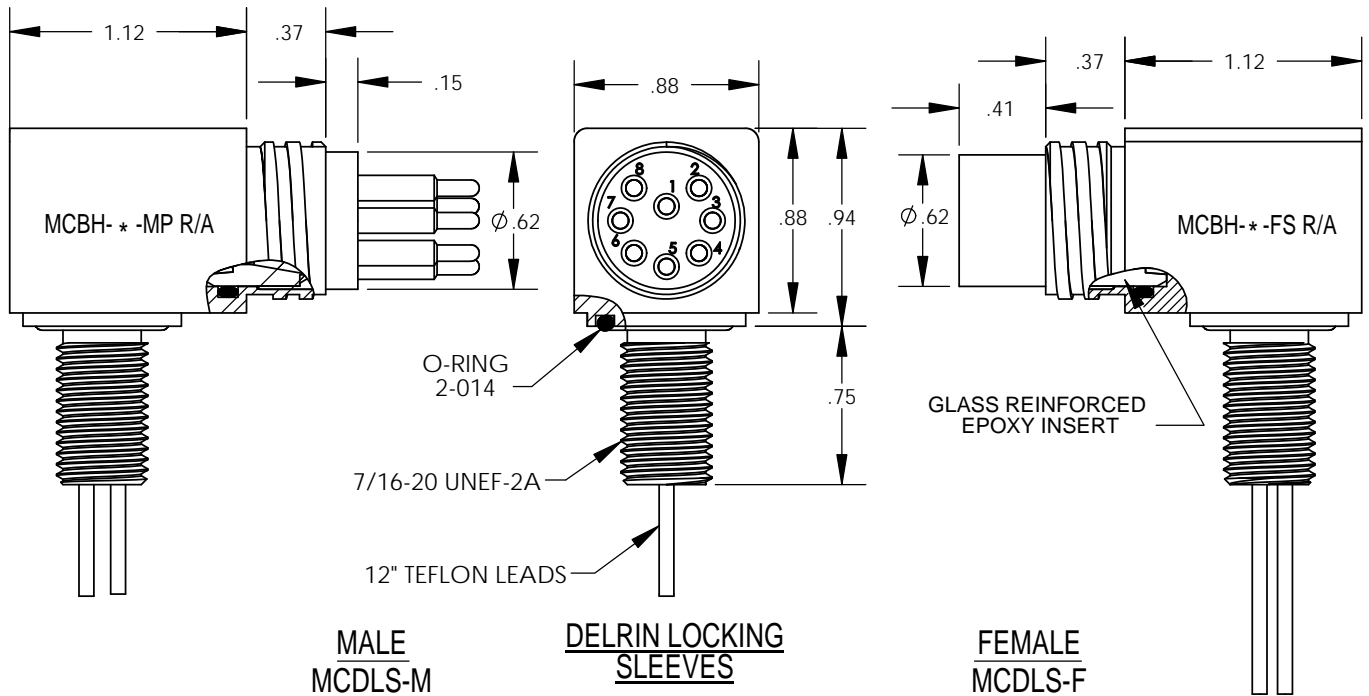

CONTACT CONFIGURATION (MP FACE VIEW)

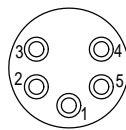

5 #15

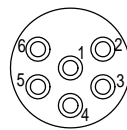

6 #15

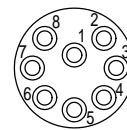

8 #15

MOUNTING TORQUE FOR MCIL/BH (WB)-FS/MP	not to exceed 100 in lbs
MATED PRESSURE RATING (psi)	10,000
DUMMY PLUG FOR MCIL/BH (WB)-FS	MCDC- * -MP
DUMMY PLUG FOR MCIL/BH (WB)-MP	MCDC- * -FS
* Specify number of contacts. * Dummy plugs found on page 65 125	

THIS PAGE INTENTIONALLY LEFT BLANK

DESCRIPTION AND MATERIAL	<ul style="list-style-type: none">• Body and engaging nut are 316 Stainless Steel, passivated per QQ-P-35 Type VI.• To 10,000 PSI in mated condition.• Bulkhead connector design open face pressure rated to 5000 PSI.• Contacts gold plated per MIL-G-45204.• Engaging nuts have Acme threads for rugged applications and for quick connection (shell size 15 has standard V thread).• Working voltage - 600 VDC (contact factory for high voltage applications).
CABLE	<ul style="list-style-type: none">• CCP, CCP-R/A and CCR are molded on standard 24" length of 16 AWG SO cable. IE55-1508 is molded on a standard 24" length of 18 AWG SO cable.• Other cable options available at customer's request.• BCR/FCR have 48" teflon leads, Type E per MIL 16878/4 16 AWG.• Un-Terminated versions of CCP available.
USES	<ul style="list-style-type: none">• Heavy Duty applications.• Hazardous environment.• Power Transmission.• Signal Telemetry.• ROV applications.
GUIDELINES	<ul style="list-style-type: none">• All mounting and sealing surfaces require a 32 finish.• Lubricate mating surfaces with 3M Silicone Lubricant or equivalent, DO NOT GREASE! Connectors must be lubricated on a regular basis.• Lubricate o-rings with Dow Corning #111 Valve Lubricant or equivalent.• Use Dust Caps and keep connectors clean to prevent damage in storage and service.• Keep o-ring grooves clean and avoid cuts, nicks and tears on rubber surfaces.• Elastomers can be seriously degraded if exposed to direct sunlight or high ozone levels for extended periods of time.• Clean plugs and receptacles with soap and fresh water. Rinse out with alcohol, allowing connector to air dry.• Replace o-rings when re-using connectors.
NOTE	<ul style="list-style-type: none">• Also available as inverted series, see following section.
Specifications for: SUBMINIATURE CONNECTOR (Bulletin 70 03/06)	<ul style="list-style-type: none">• Body and engaging nut are 6AL-4V Titanium. Engaging nut is Tiodized per AMS 2488 TYPE II.• Working voltage - 300 VDC.• IE55-1204/06-CCP, CCP-R/A and CCR are molded on standard 24" 22 AWG polyurethane jacketed cable. IE55W-1002/03-CCP, CCP-R/A and CCR are molded on standard 24" 20 AWG Belden cable.• IE55-1204/06-BCR/FCR are molded on standard 6" Teflon lead, Type E per MIL16878/4, 24 AWG. IE55W-1002/03-BCR/FCR are molded on standard 6" Teflon lead, Type E per MIL 16878/4, 22 AWG.• Mainly used on small sensor packages.• Light duty applications only.

IE55W-10

IE55(W) WET PLUGGABLE RUBBER MOLDED METAL SHELL SERIES

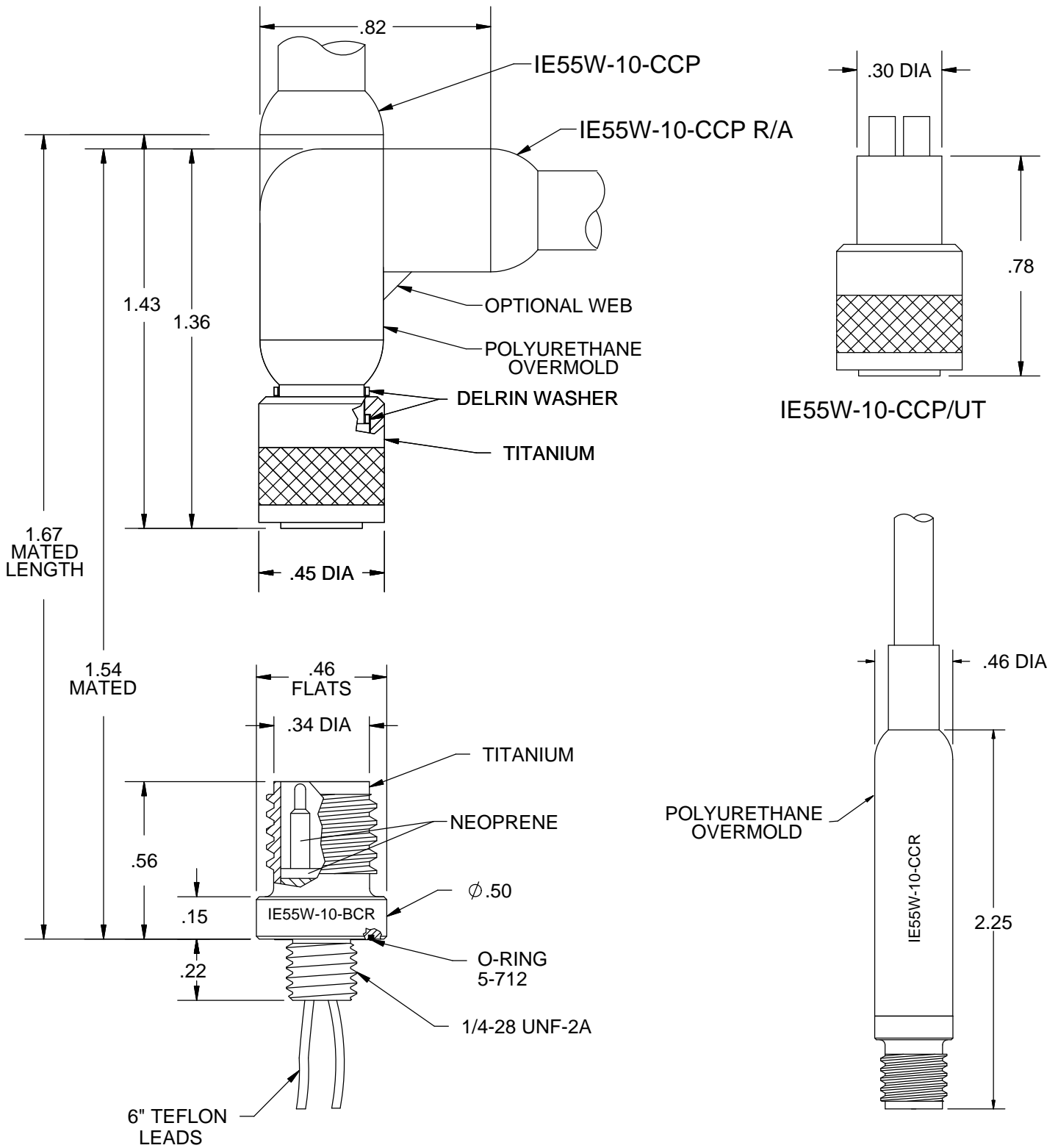

IE55W-10

IE55(W) WET PLUGGABLE RUBBER MOLDED METAL SHELL SERIES

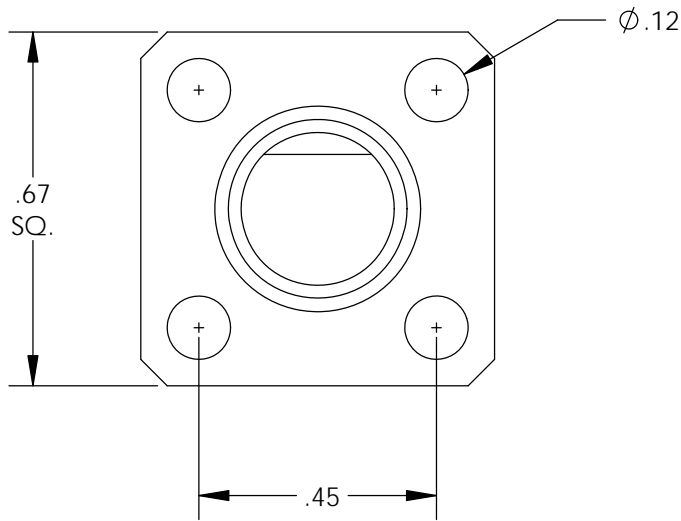

CONTACT CONFIGURATION (BCR FACE VIEW)

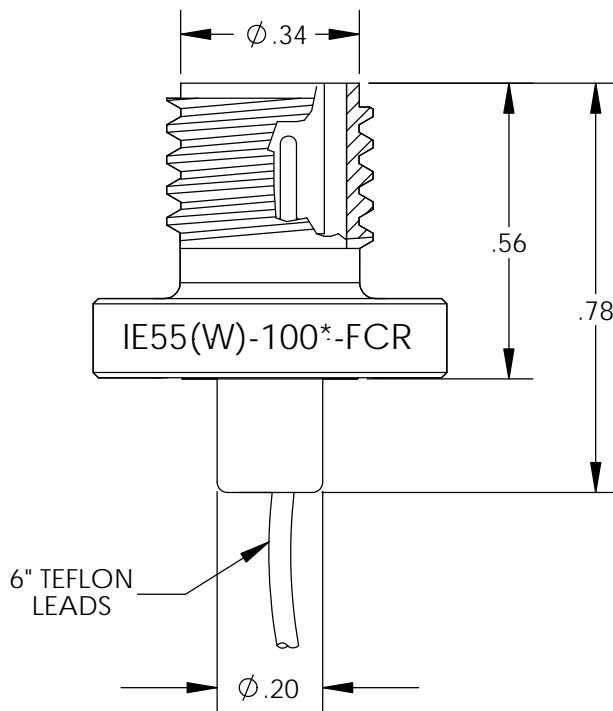
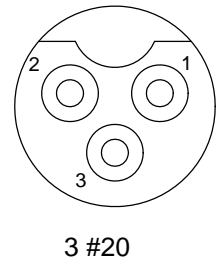
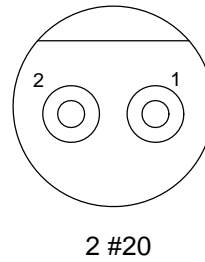

MATED PRESSURE RATING (psi)	10,000
MOUNTING TORQUE FOR BCR	not to exceed 15 in lbs
DUMMY PLUG FOR BCR	IE55W-10 *-SCP
DUMMY PLUG FOR CCP	IE55W-10* -SCR
* Specify number of contacts.	

IE55-12

IE55 RUBBER MOLDED
METAL SHELL SERIES

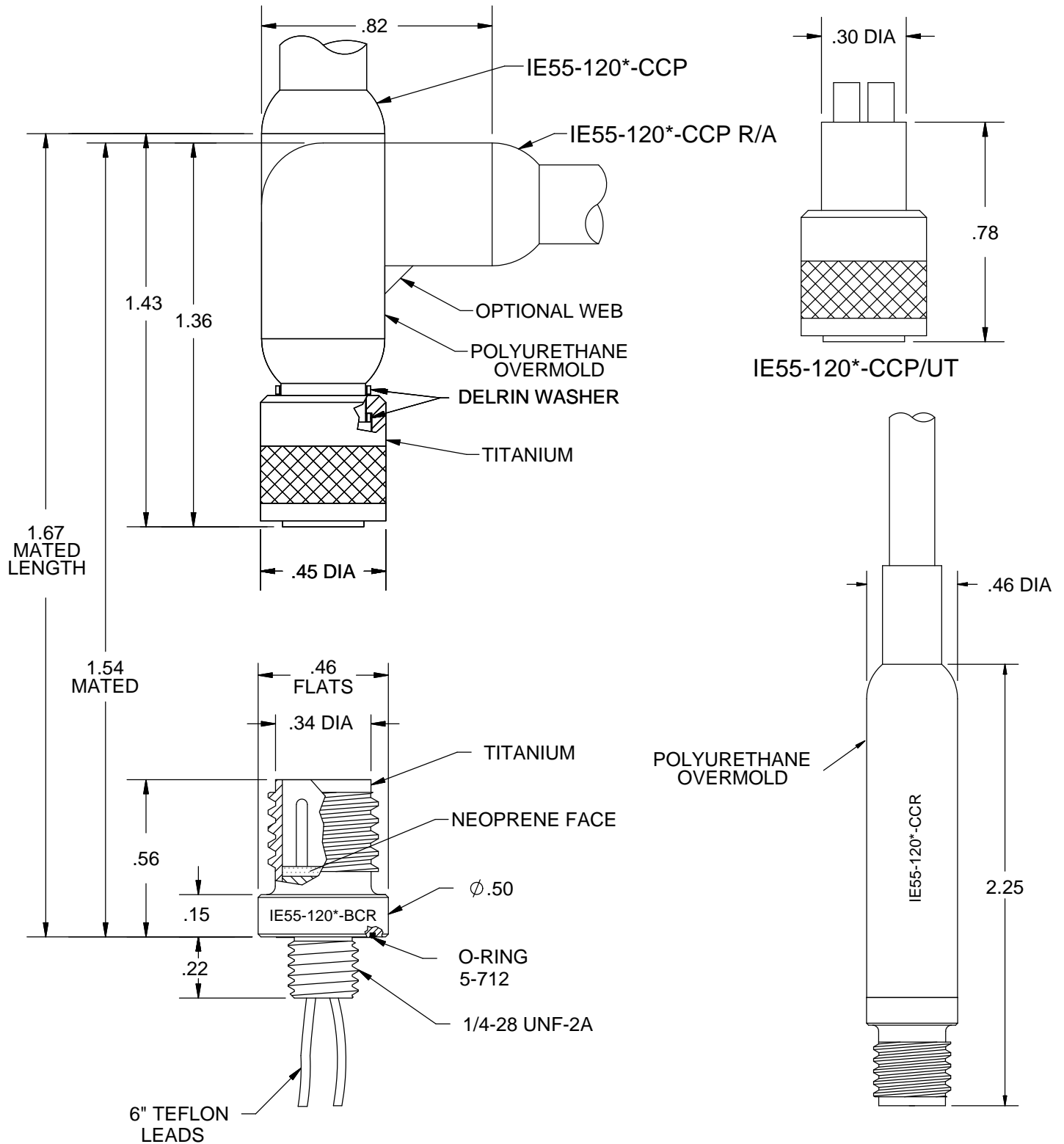

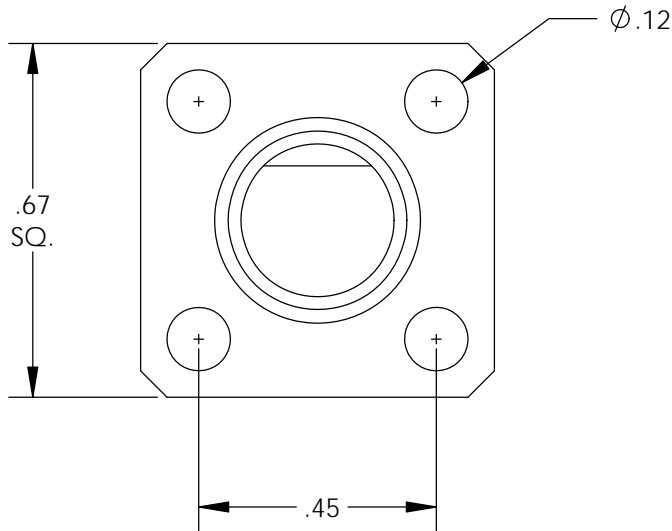

CONTACT CONFIGURATION
(BCR FACE VIEW)

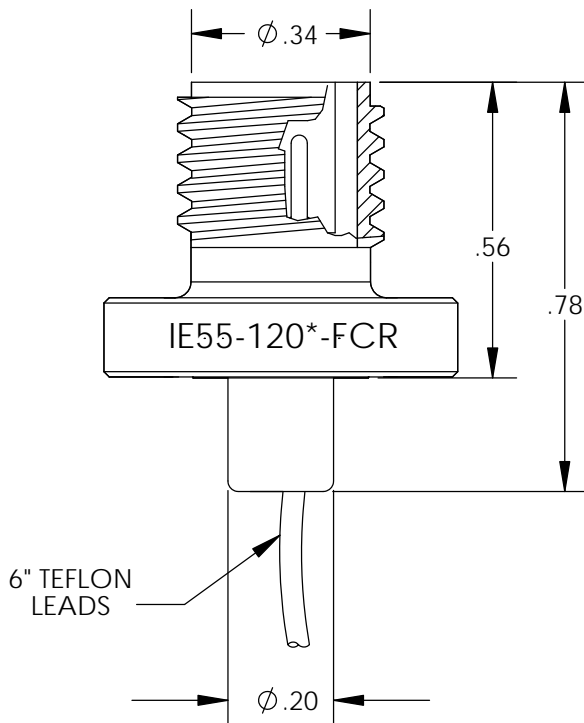
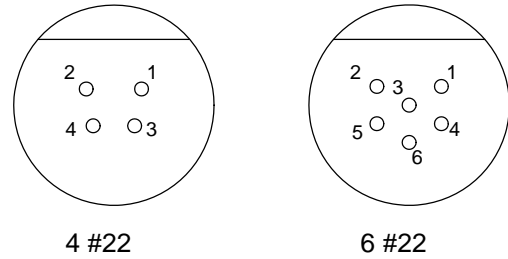

MATED PRESSURE RATING (psi)	10,000
MOUNTING TORQUE FOR BCR	not to exceed 15 in lbs
DUMMY PLUG FOR BCR	IE55-12*-SCP
DUMMY PLUG FOR CCP	IE55-12*-SCR
* Specify number of contacts	

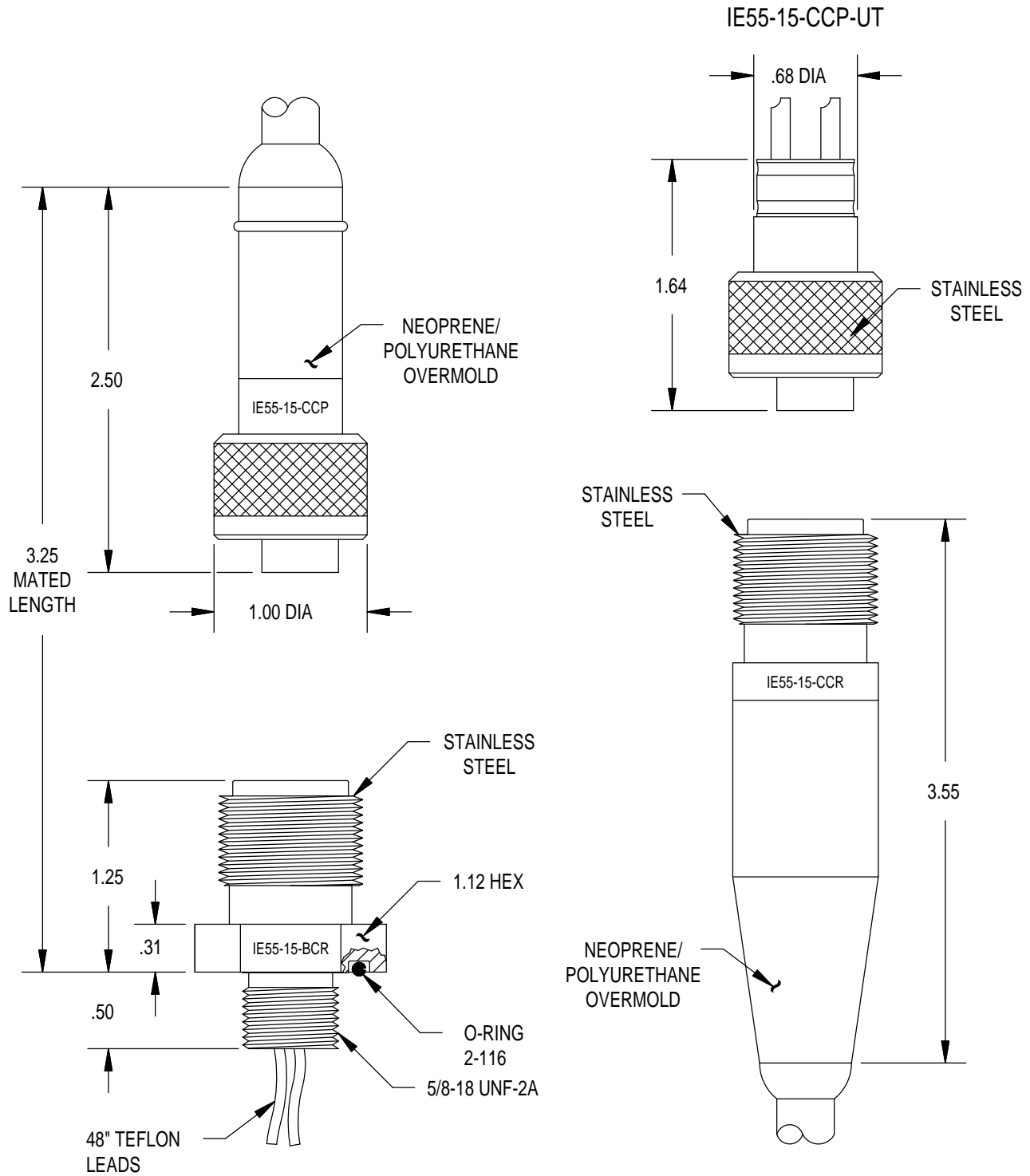

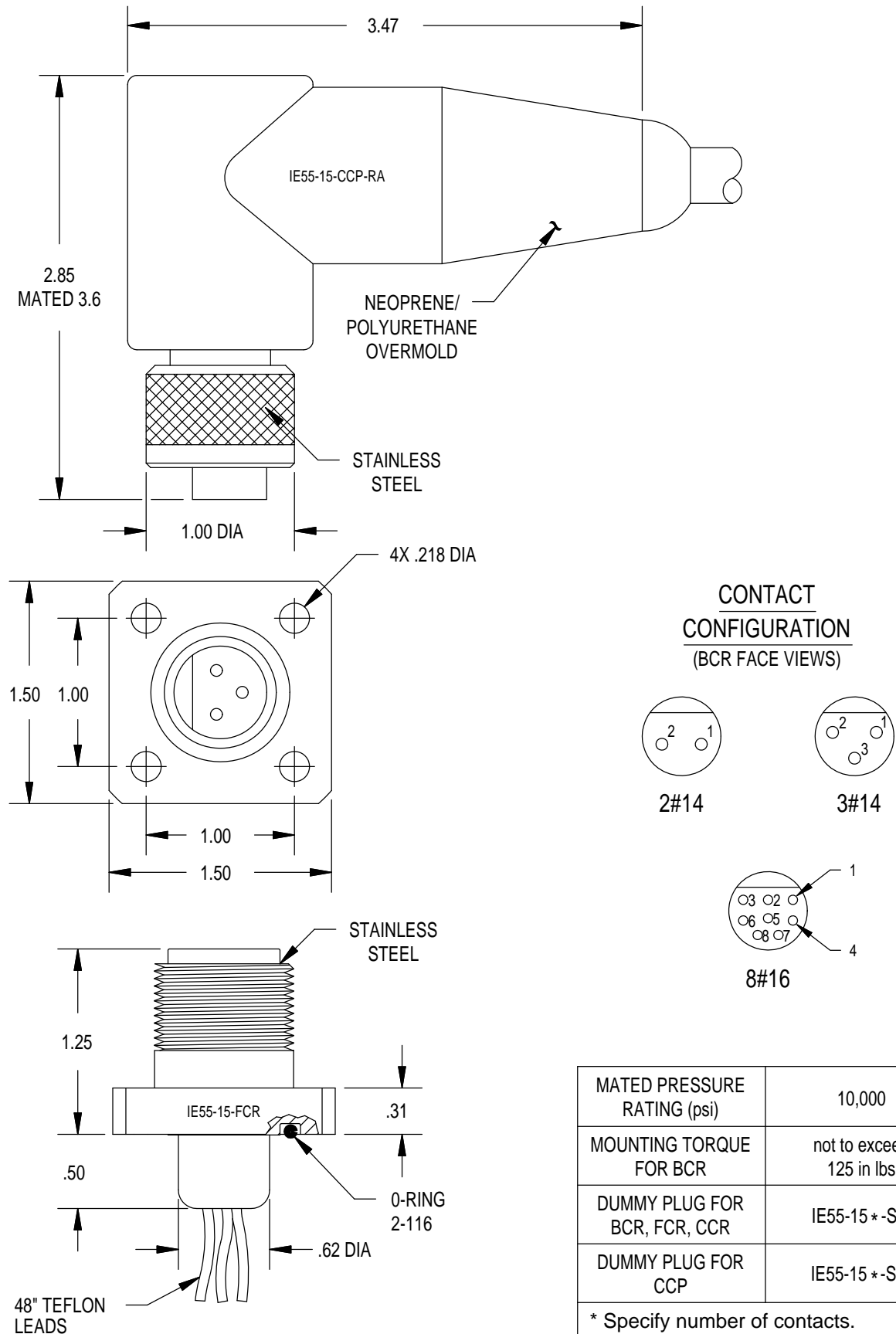

MATED PRESSURE RATING (psi)	10,000
MOUNTING TORQUE FOR BCR	not to exceed 125 in lbs
DUMMY PLUG FOR BCR, FCR, CCR	IE55-15 *-SCP
DUMMY PLUG FOR CCP	IE55-15 *-SCR
* Specify number of contacts.	

INVERTED AVAILABLE

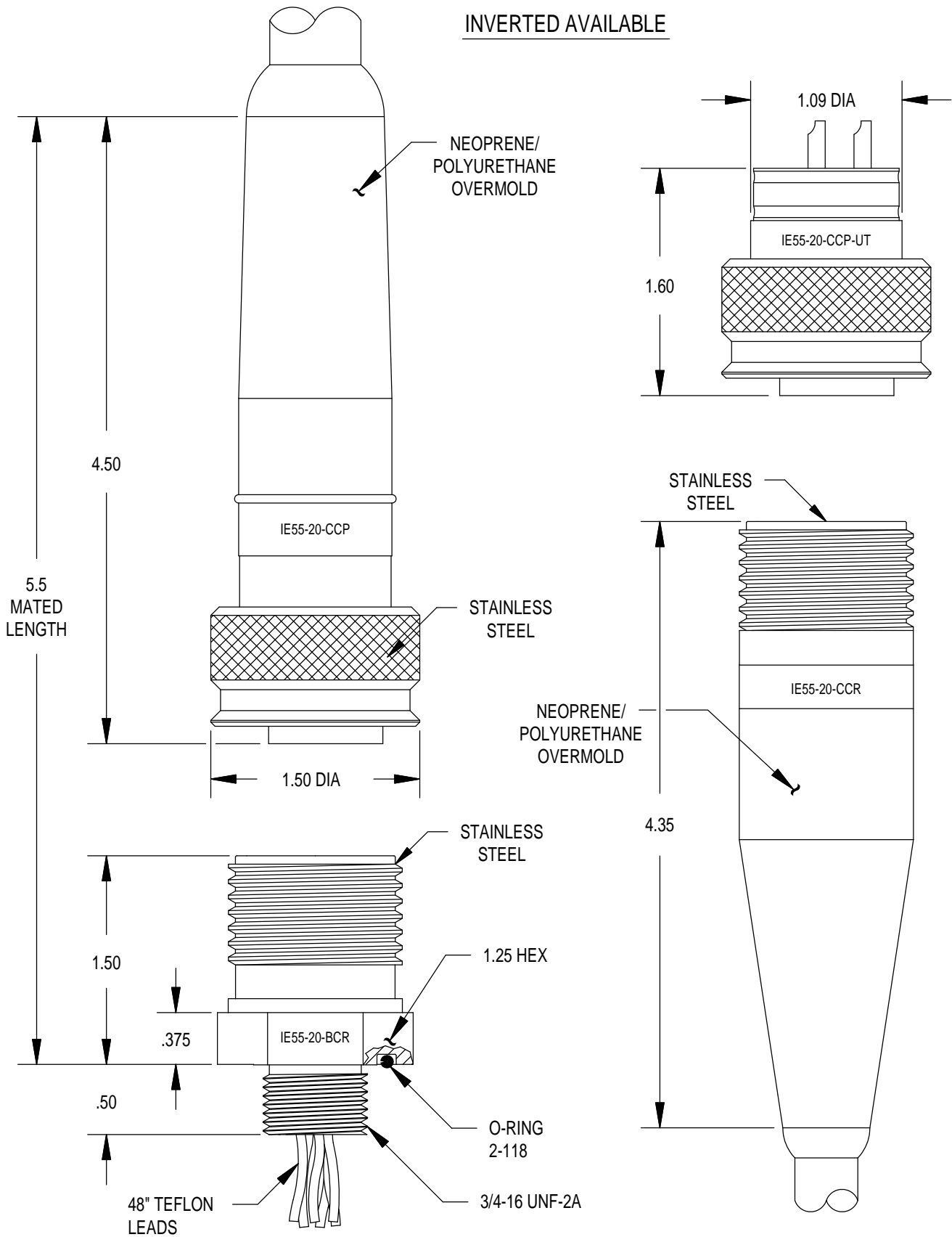

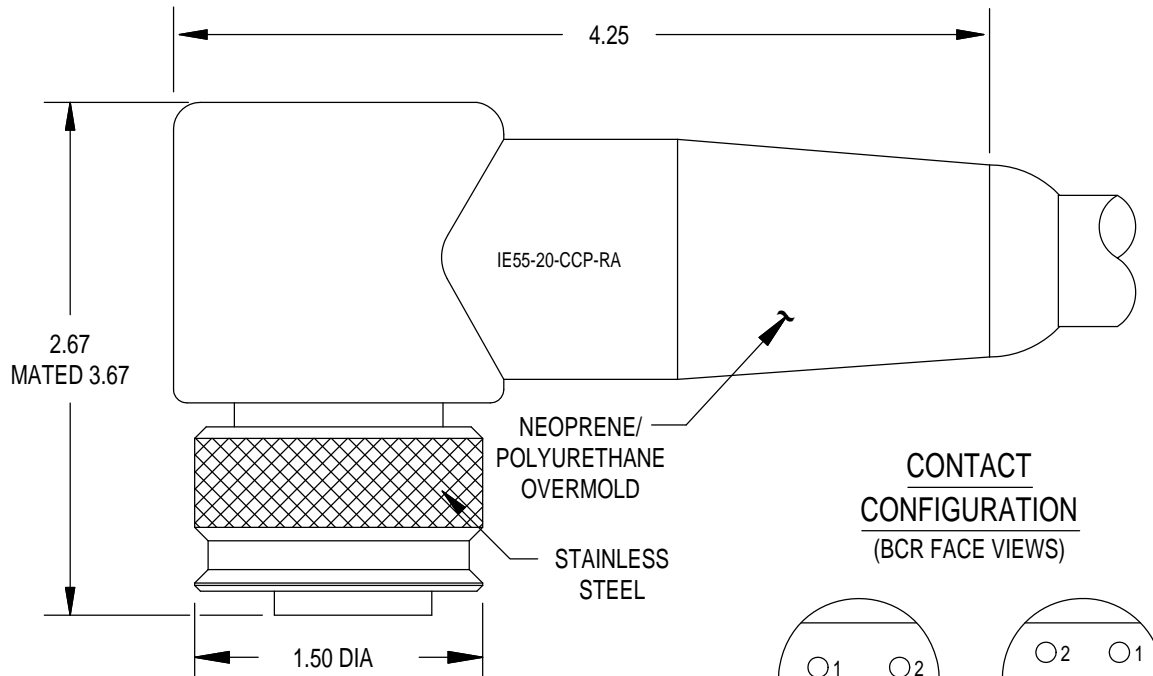

**CONTACT
CONFIGURATION**
(BCR FACE VIEWS)

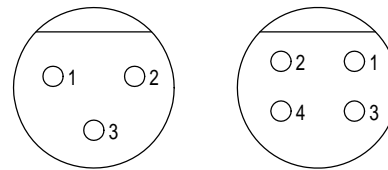

**1#8 / 3#10
(High Voltage)**

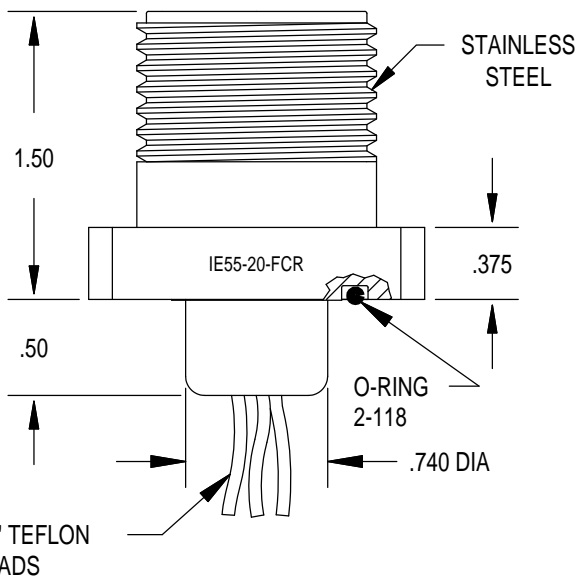
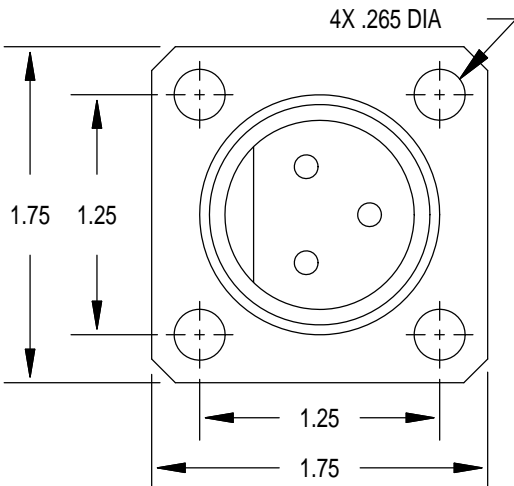
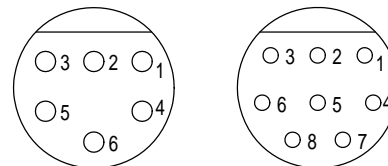

MATED PRESSURE RATING (psi)	10,000
MOUNTING TORQUE FOR BCR	not to exceed 165 in lbs
DUMMY PLUG FOR BCR, FCR, CCR	IE55-20 *-SCP
DUMMY PLUG FOR CCP	IE55-20 *-SCR
* Specify number of contacts. ** Available in high voltage	

IE55-24

IE55 RUBBER MOLDED
METAL SHELL SERIES

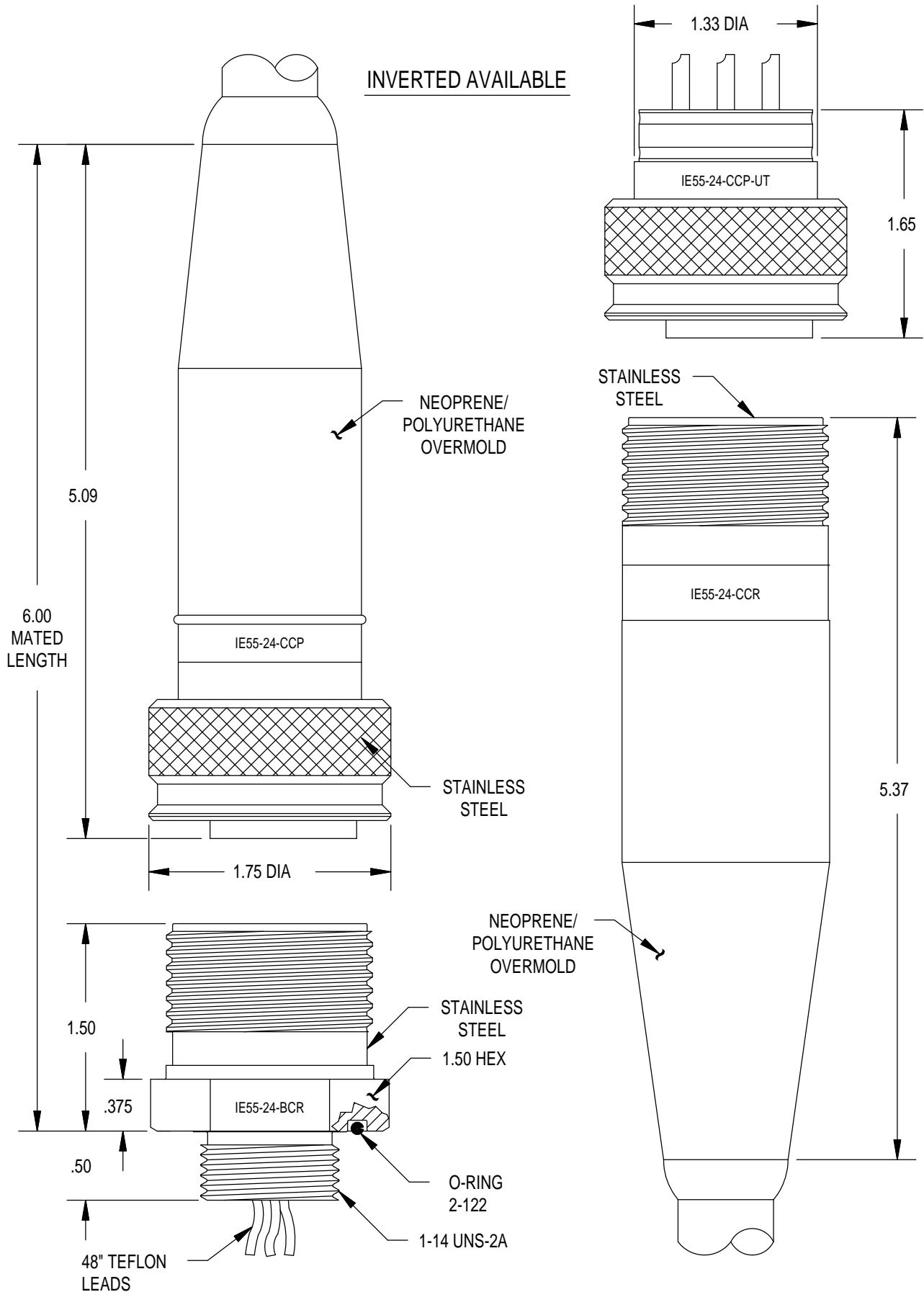

IE55-24

IE55 RUBBER MOLDED METAL SHELL SERIES

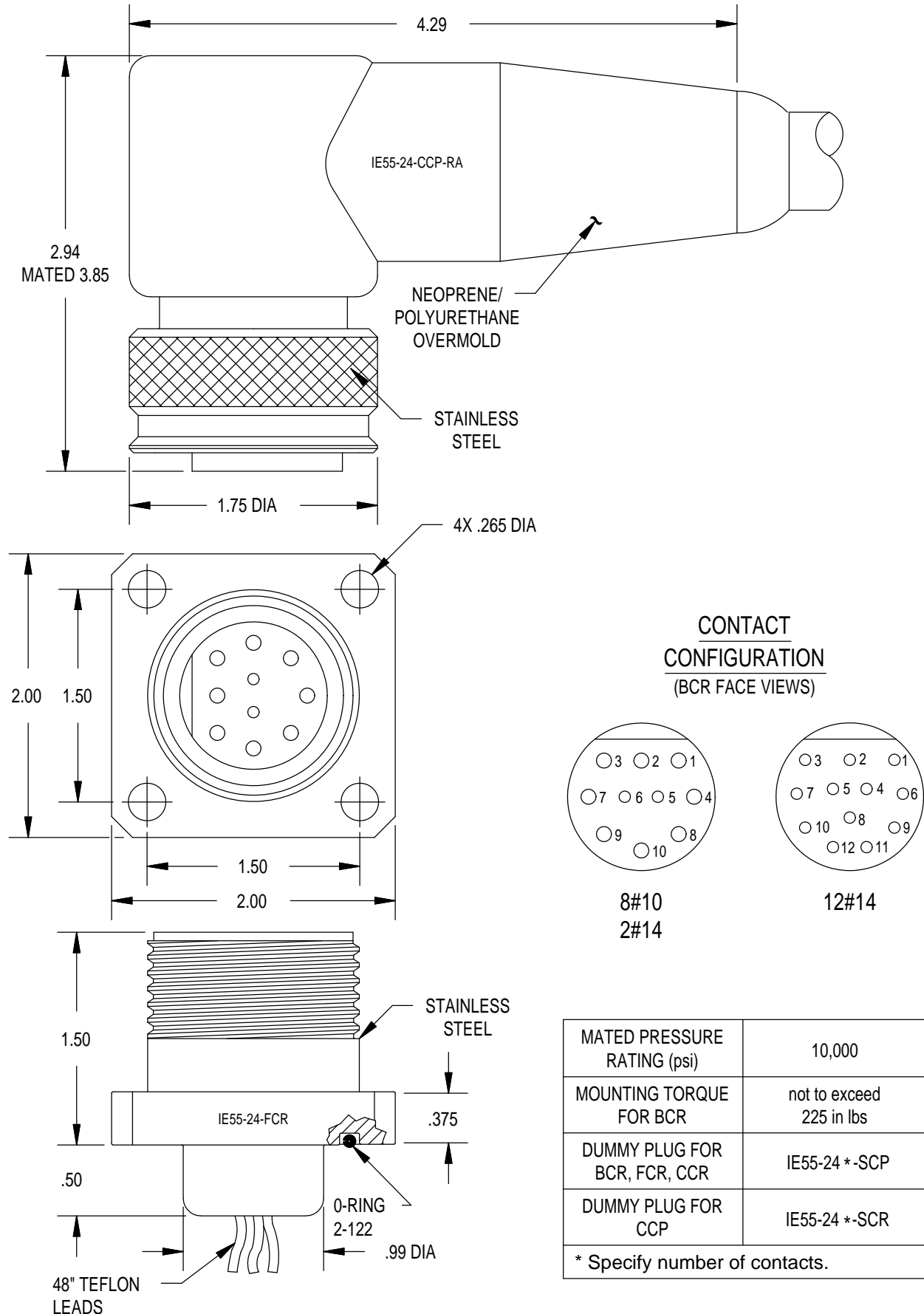

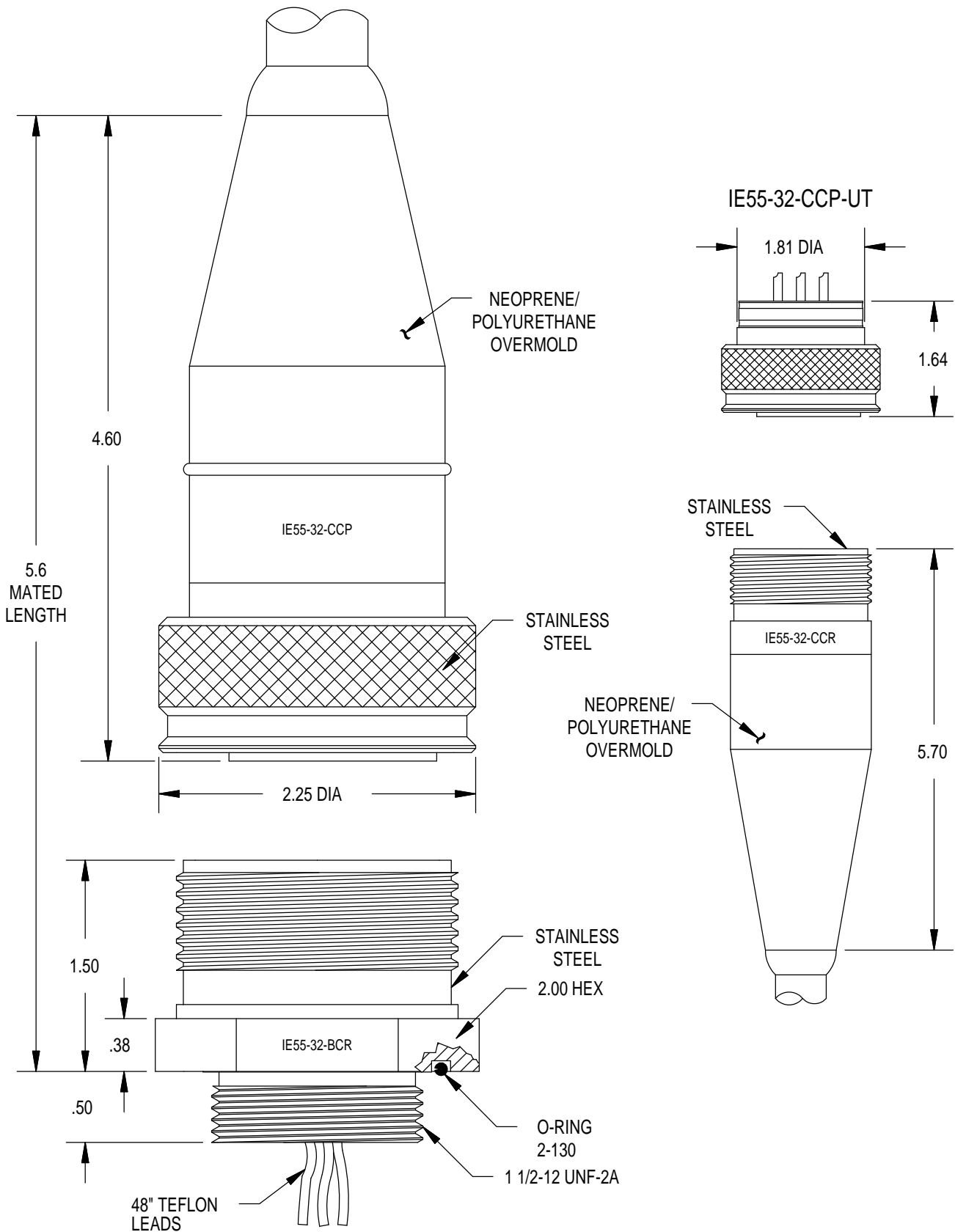

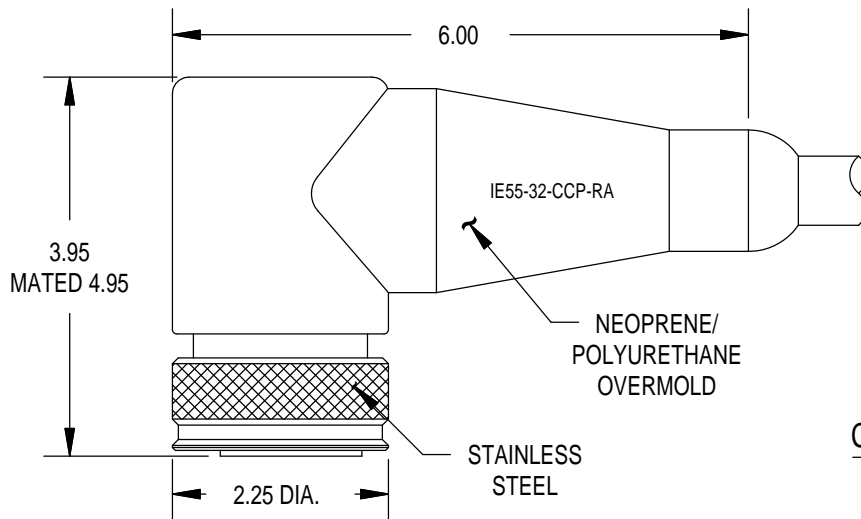

**CONTACT
CONFIGURATION**
(BCR FACE VIEWS)

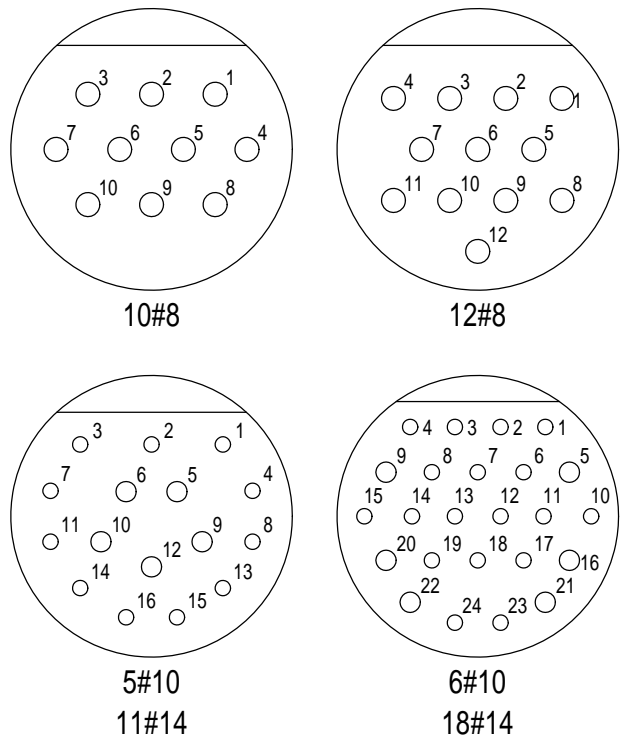
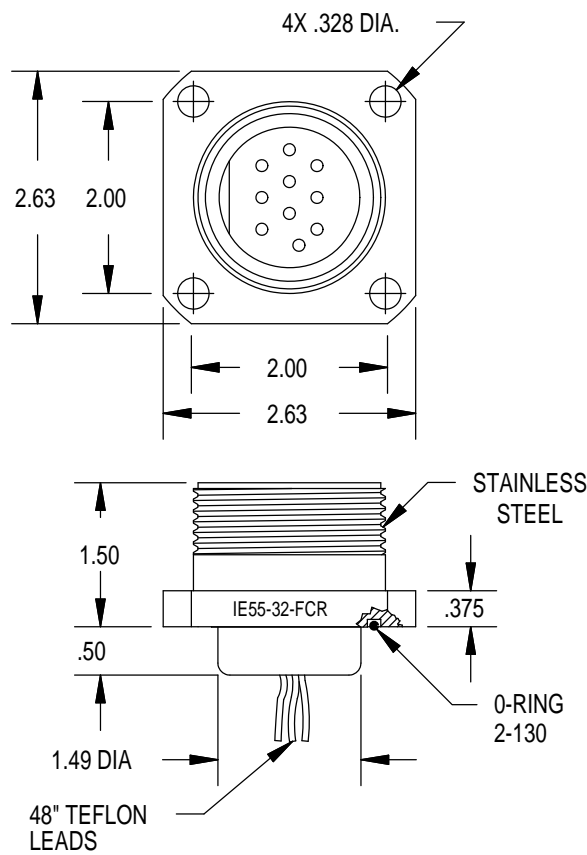

MATED PRESSURE RATING (psi)	10,000
MOUNTING TORQUE FOR BCR	not to exceed 335 in lbs
DUMMY PLUG FOR BCR, FCR, CCR	IE55-32 *-SCP
DUMMY PLUG FOR CCP	IE55-32 *-SCR
* Specify number of contacts.	

THIS PAGE INTENTIONALLY LEFT BLANK

-
- DESCRIPTION AND MATERIAL**
- Body and engaging nut are 316 Stainless Steel, passivated per QQ-P-35 Type VI.
 - To 10,000 PSI in mated condition.
 - Bulkhead connector design open face pressure rated to 5,000 PSI.
 - Contacts gold plated per MIL-G-45204.
 - Engaging nuts have Acme threads for rugged applications and a quick connection.
 - Working voltage - 600 VDC (Contact factory for high voltage applications.)
 - Bulkhead has sockets, cable connector plug has pins.
- CABLE**
- CCP, CCP-R/A and CCR are molded on standard 24" 16 AWG SO cable.
 - Other cable options available at customer's request.
 - BCR/FCR on standard 48" teflon leads, Type E per MIL 16878/4 16 AWG.
 - Un-Terminated versions of CCP available.
- USES**
- Heavy Duty applications.
 - Hazardous environment.
 - Power Transmission.
 - Signal Telemetry.
 - ROV applications.
- GUIDELINES**
- All mounting and sealing surfaces require a 32 finish.
 - Lubricate mating surfaces with 3M Silicone Lubricant or equivalent, DO NOT grease! Connectors must be lubricated on a regular basis.
 - Lubricate o-rings with Dow Corning #111 Valve Lubricant or equivalent.
 - Use Dust Caps and keep connectors clean to prevent damage in storage and service.
 - Keep o-ring grooves clean and avoid cuts, nicks and tears on rubber surfaces.
 - Elastomers can be seriously degraded if exposed to direct sunlight or high ozone levels for extended periods of time.
 - Clean plugs and receptacles with soap and fresh water. Rinse out with alcohol, allowing connector to air dry.
 - Replace o-rings when re-using connectors.

IE55V-20

IE55V INVERTED RUBBER MOLDED METAL SHELL SERIES

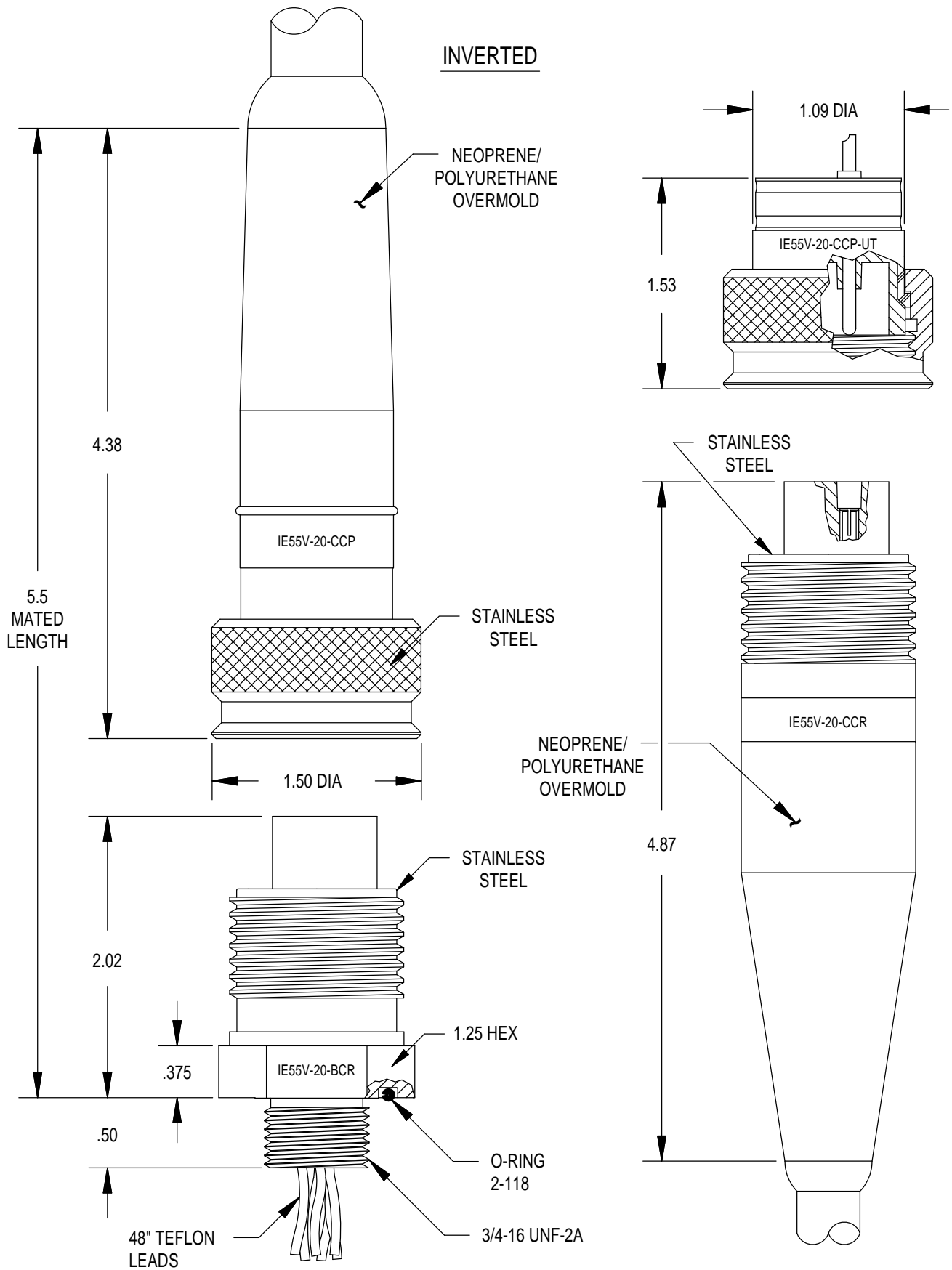

IE55V-20

IE55V INVERTED RUBBER MOLDED METAL SHELL SERIES

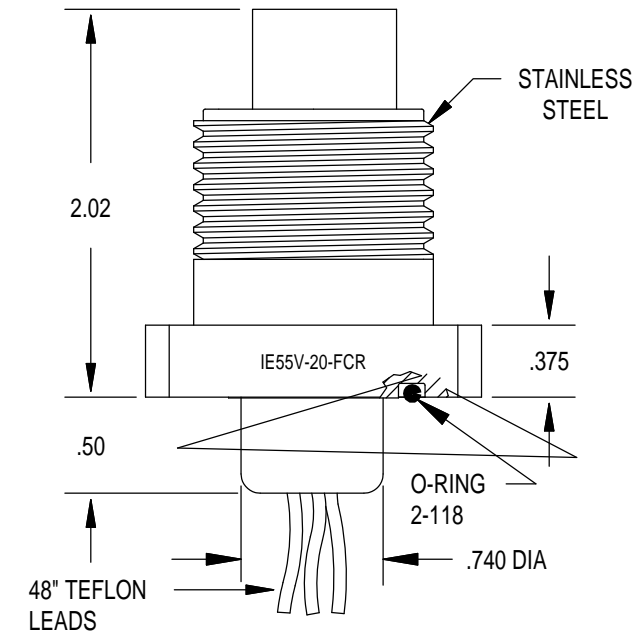
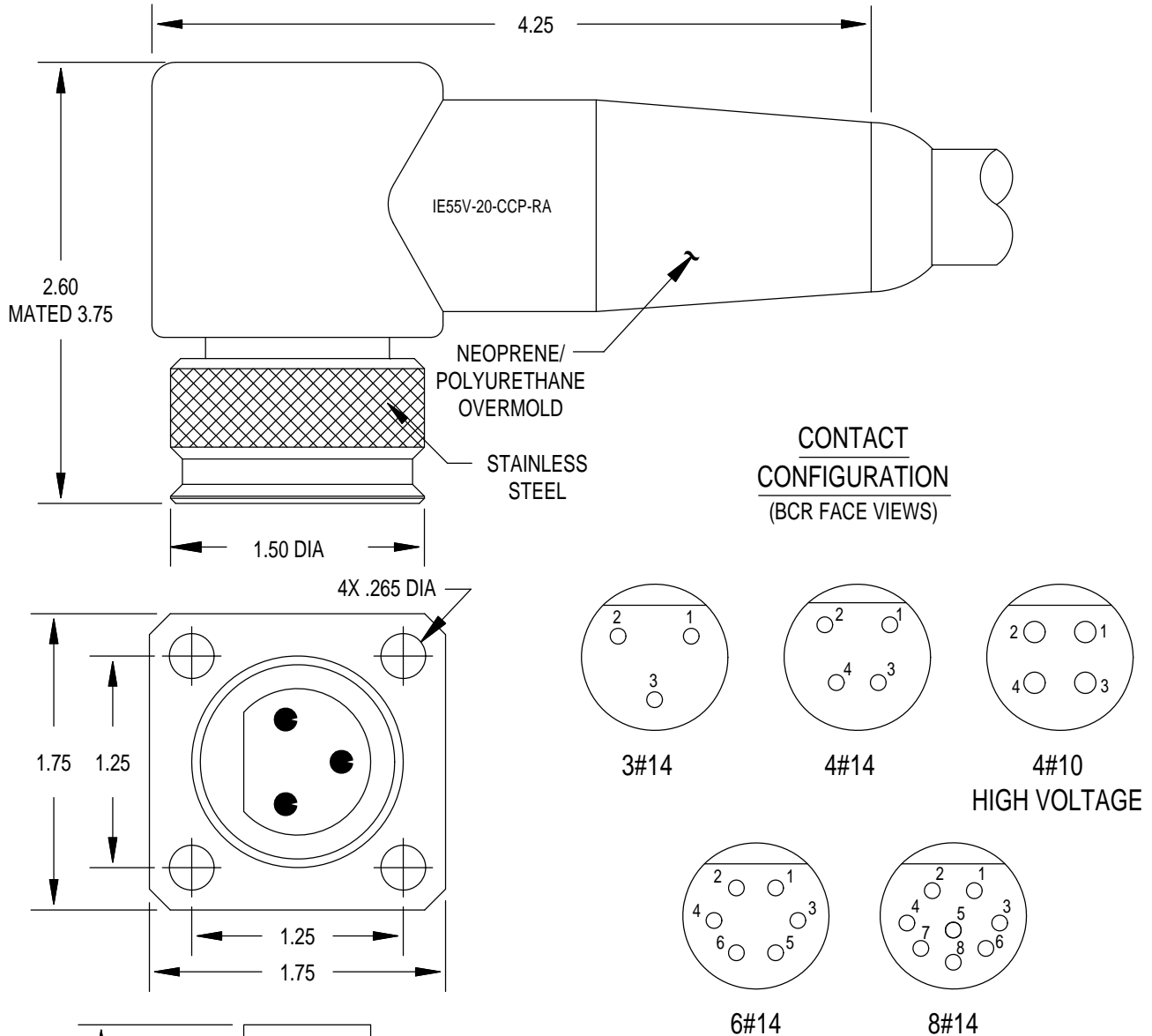

MATED PRESSURE RATING (psi)	10,000
MOUNTING TORQUE FOR BCR	not to exceed 165 in lbs
DUMMY PLUG FOR BCR, FCR, CCR	IE55V-20 *-SCP
DUMMY PLUG FOR CCP	IE55V-20 *-SCR
* Specify number of contacts.	

IE55V-24

IE55V INVERTED RUBBER MOLDED METAL SHELL SERIES

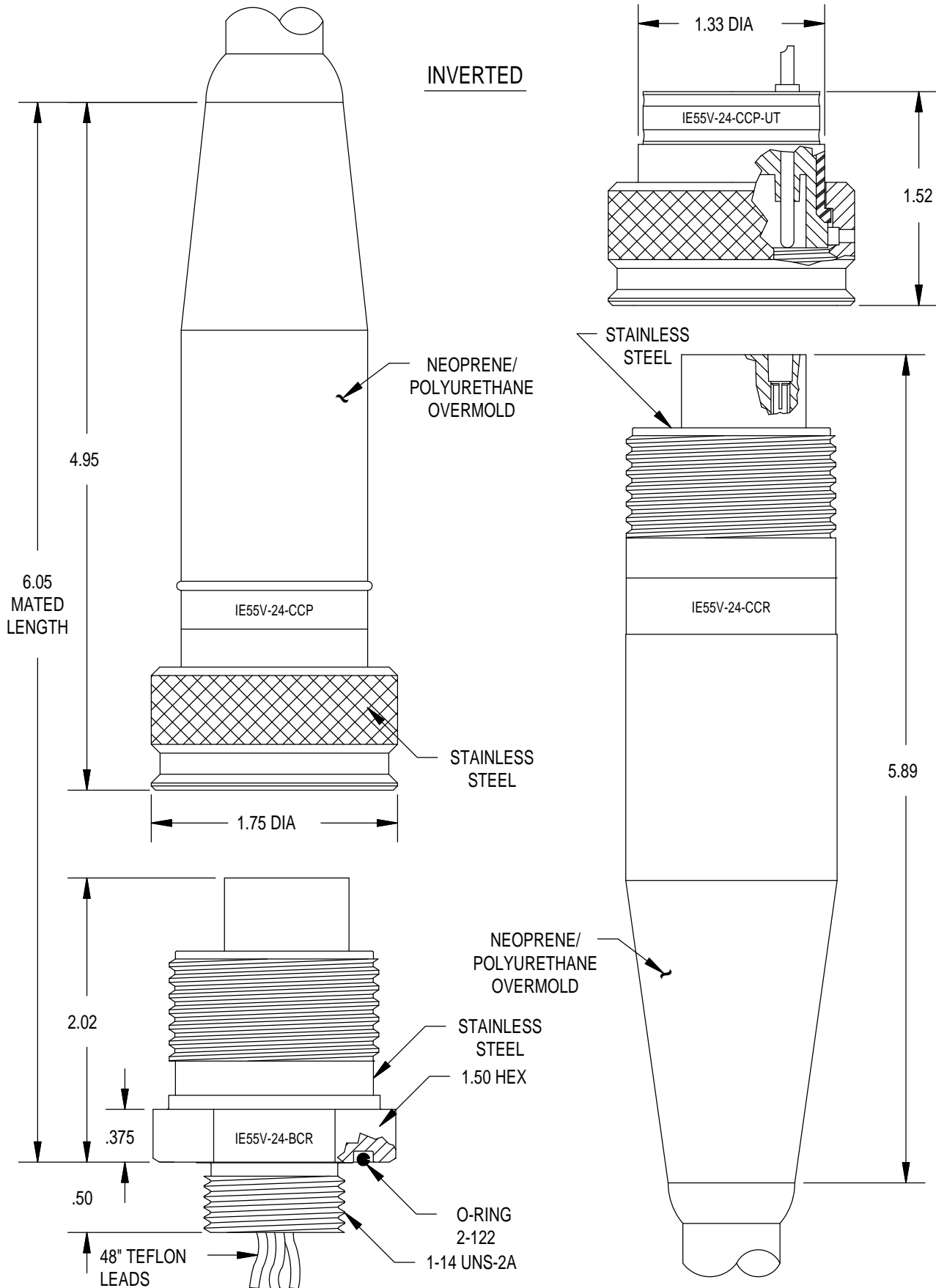

IE55V-24

IE55V INVERTED RUBBER MOLDED METAL SHELL SERIES

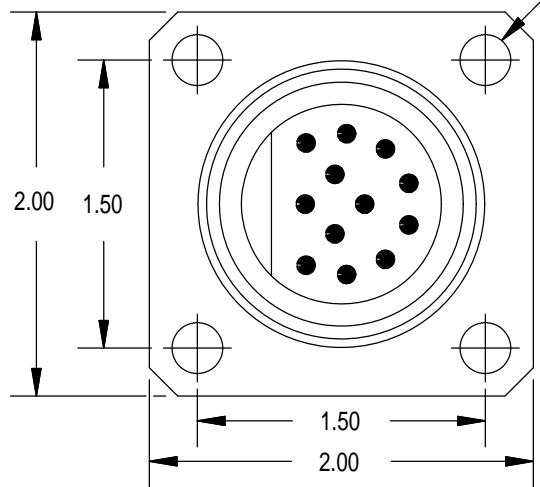
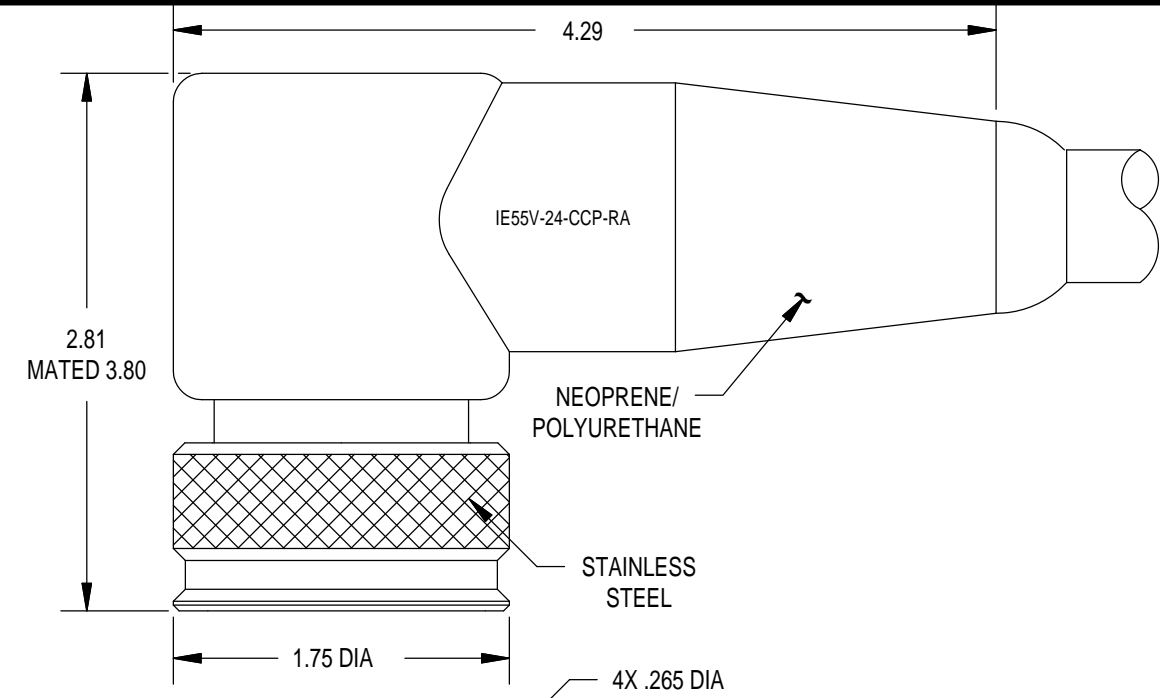

CONTACT
CONFIGURATION
(BCR FACE VIEW)

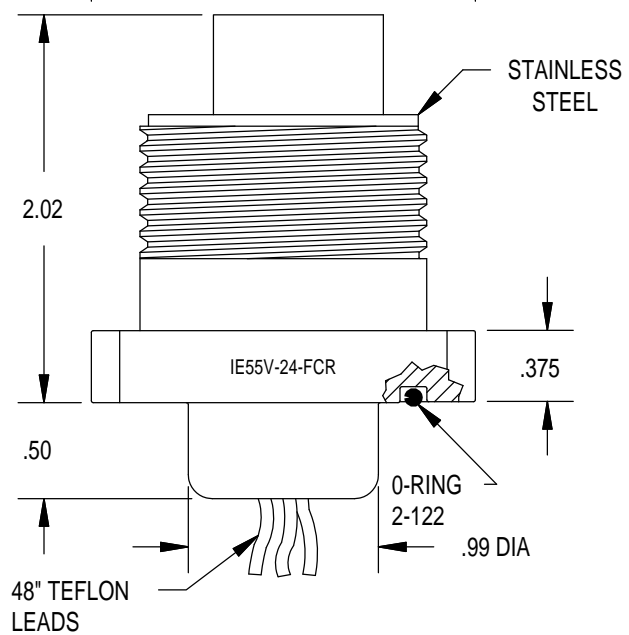
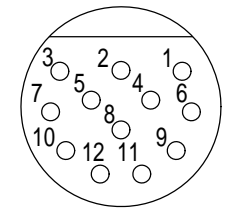

MATED PRESSURE RATING (psi)	10,000
MOUNTING TORQUE FOR BCR	not to exceed 225 in lbs
DUMMY PLUG FOR BCR, FCR, CCR	IE55V-2412-SCP
DUMMY PLUG FOR CCP	IE55V-2412-SCR

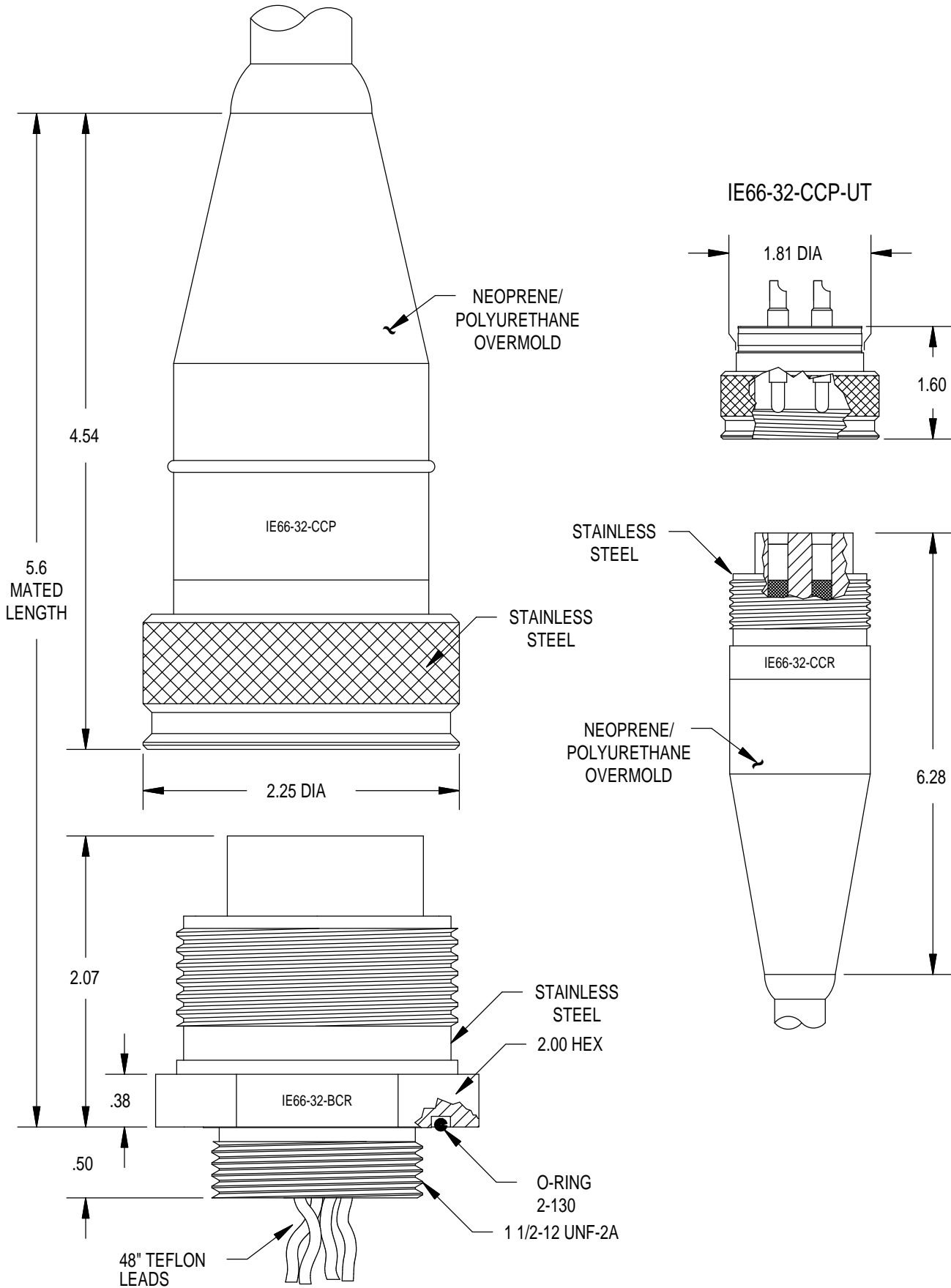

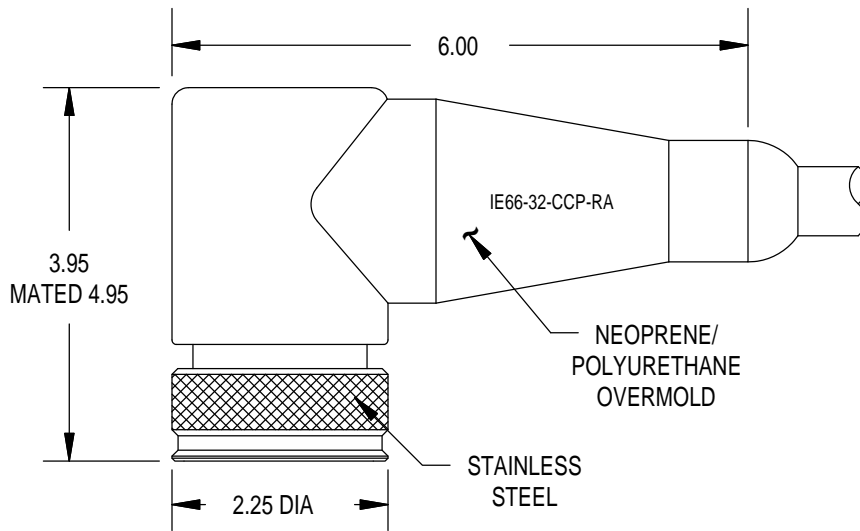

**CONTACT
CONFIGURATION**
(BCR FACE VIEWS)

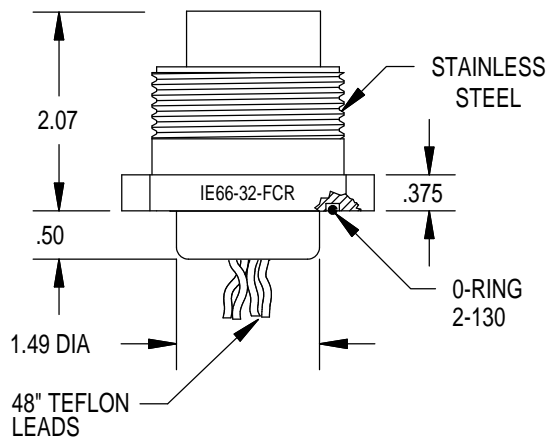
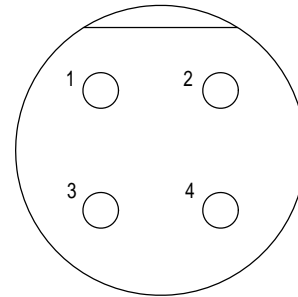
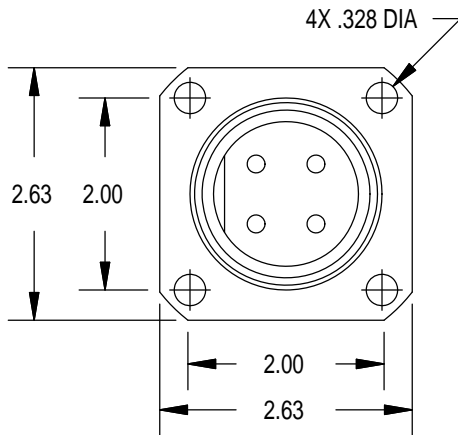

MATED PRESSURE RATING (psi)	10,000
MOUNTING TORQUE FOR BCR	not to exceed 335 in lbs
DUMMY PLUG FOR BCR, FCR, CCR	IE66-3204-SCP
DUMMY PLUG FOR CCP	IE66-3204-SCR

THIS PAGE INTENTIONALLY LEFT BLANK

DESCRIPTION AND MATERIAL	<ul style="list-style-type: none">• Molded neoprene with improved sealing ability.• Two to eight contacts.• Up to 300 VDC, 7 AMPS.• Rated to 10,000 psi, contact factory for higher rating.• Bulkhead connector design open face pressure rated to 5000 PSI.• O-rings molded in female connector.
CABLE	<ul style="list-style-type: none">• Connectors in this series are molded on a 24" length of 18 AWG SO cable (2 contact on SJO) unless otherwise specified.• Bulkhead connectors have 12" teflon leads, Type E per MIL 16878/4 18 AWG, or 12" Belden 34918 leads (Neoprene jacket).
USES	<ul style="list-style-type: none">• Mates with other manufacturers connectors of same design.• Permits underwater plugging and unplugging with power off.• Light to heavy duty applications.• Hazardous environments.
GUIDELINES	<ul style="list-style-type: none">• All mounting surfaces require a 32 finish.• Lubricate male pins liberally with Dow Corning #111 Valve Lubricant or equivalent and apply a small amount in each hole of female socket. Connectors must be lubricated on a regular basis.• Lubricate o-rings with Dow Corning #111 Valve Lubricant or equivalent.• Replace o-rings when re-using connectors.• Align index pin prior to mating.• Avoid nicks and cuts around contacts as these are the sealing surfaces.• Elastomers can be seriously degraded if exposed to direct sunlight or high ozone levels for extended periods of time.• Do not over tighten bulkhead nuts.• Do not pull on cable to disconnect.• Avoid sharp bends at cable entry to connector.

IE2-BC

IE UNDERWATER PLUGGABLE SERIES

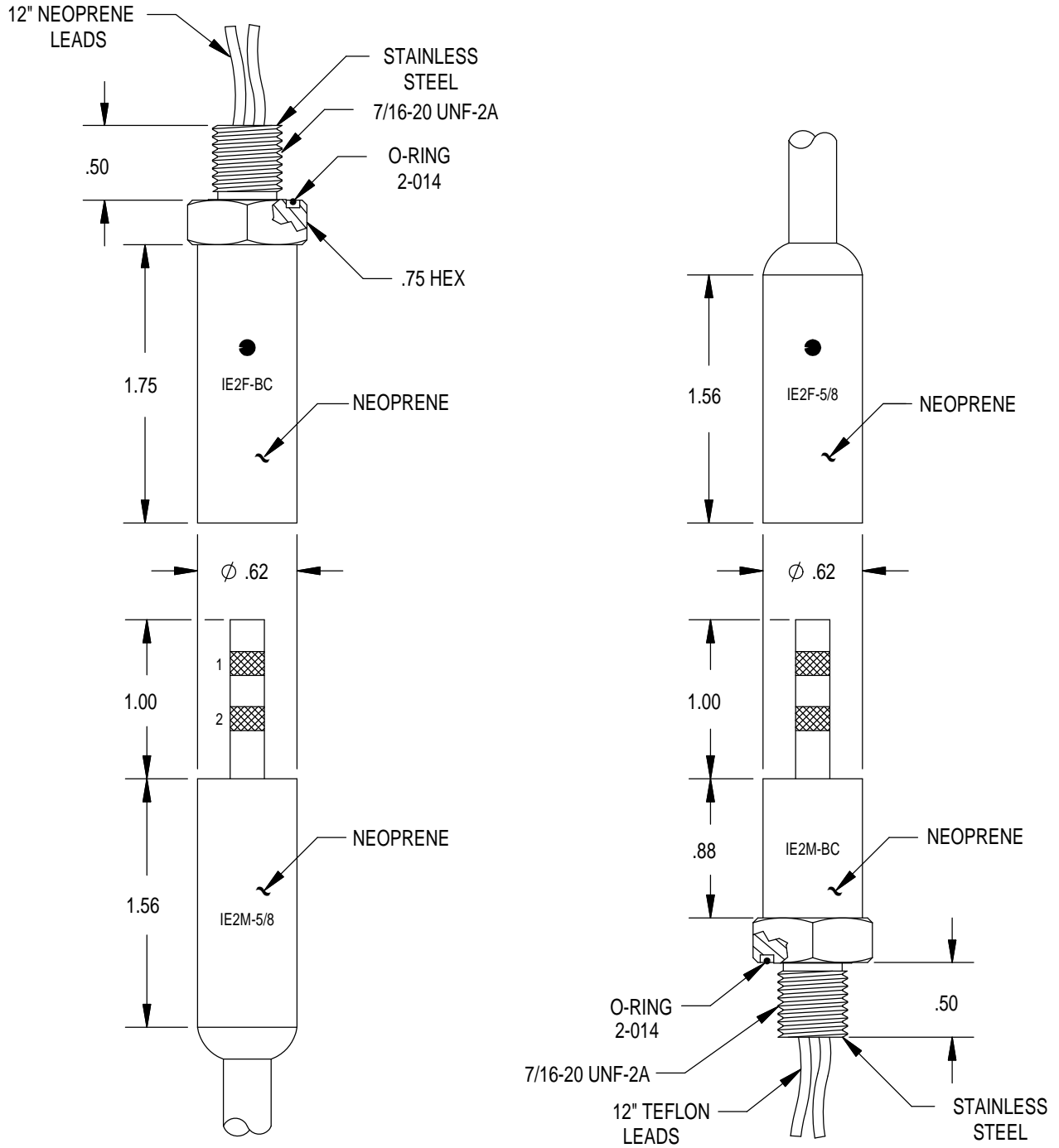

MOUNTING TORQUE FOR BC	not to exceed 100 in lbs
MATED PRESSURE RATING (psi)	10,000
DUMMY PLUG FOR IE2M-5/8, IE2M-BC	IE2F-5/8-DO *
DUMMY PLUG FOR IE2F-BC, IE2F-5/8	IE2M-5/8-DO *
* Dummy plugs found on Page 75 62. * Shorted dummies (DS) available upon request.	

IERD2-BC

IE UNDERWATER
PLUGGABLE SERIES

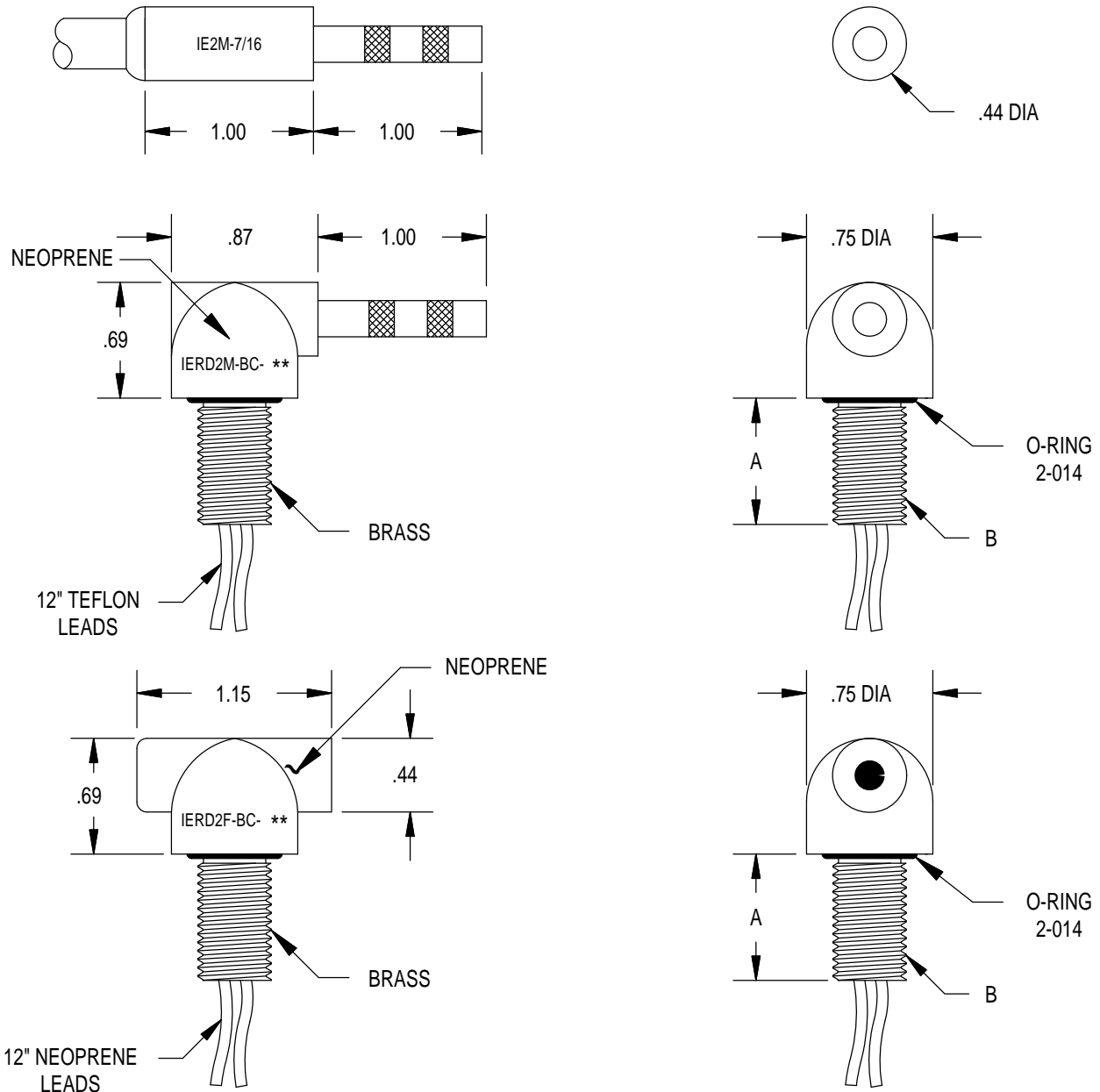

MOUNTING TORQUE FOR BC	not to exceed 100 in lbs
MATED PRESSURE RATING (psi)	10,000
DUMMY PLUG FOR IERD2F-BC	IE2M-7/16-DO *
DUMMY PLUG FOR IERD2M-BC	IE2F-5/8 DO *
<p>* Dummy plugs found on Page 75 62. ** Shorted dummies (DS) available upon request. *** See chart for thread specifications. **** Specify M/F</p>	

PART NUMBER	B	A
IERD2****-BC-1	3/8-24 UNF-2A	.50
IERD2****-BC-2	3/8-24 UNF-2A	.75
IERD2****-BC-3	3/8-24 UNF-2A	1.00
IERD2****-BC-4	7/16-20 UNF-2A	.50
IERD2****-BC-5	7/16-20 UNF-2A	.75
IERD2****-BC-6	7/16-20 UNF-2A	1.00

IESQ4-BC

IE UNDERWATER
PLUGGABLE SERIES

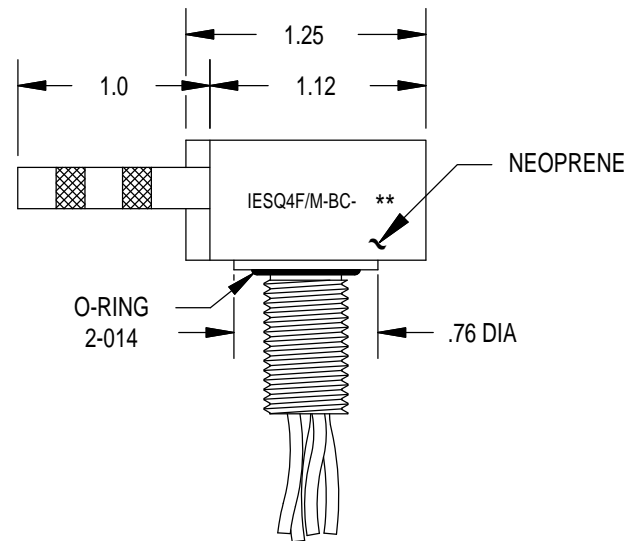
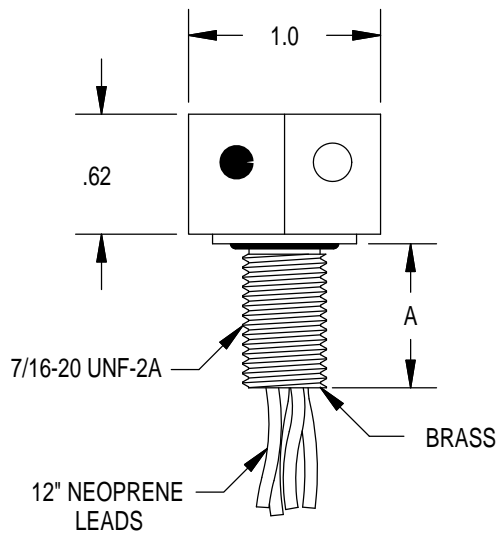
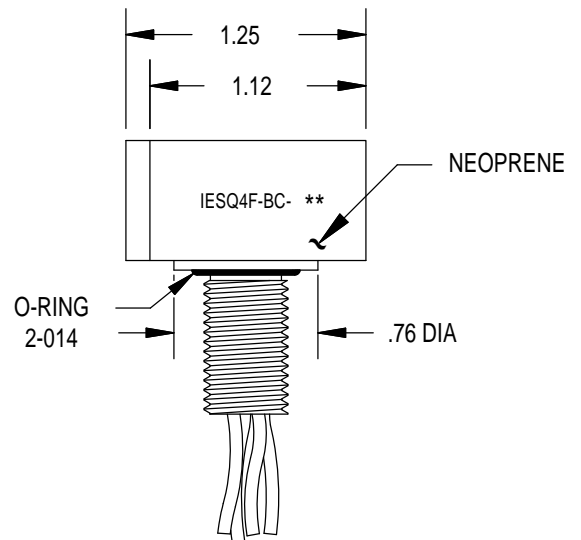
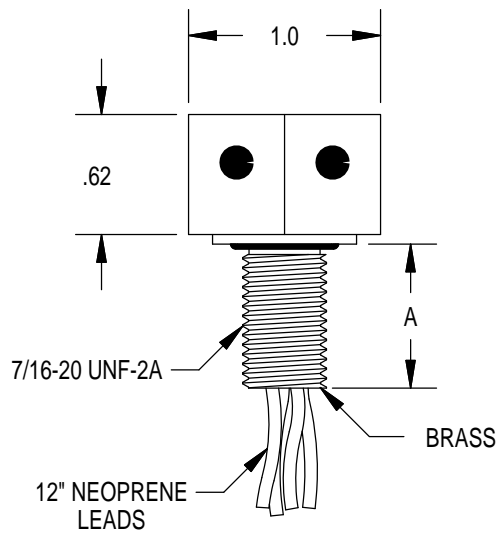
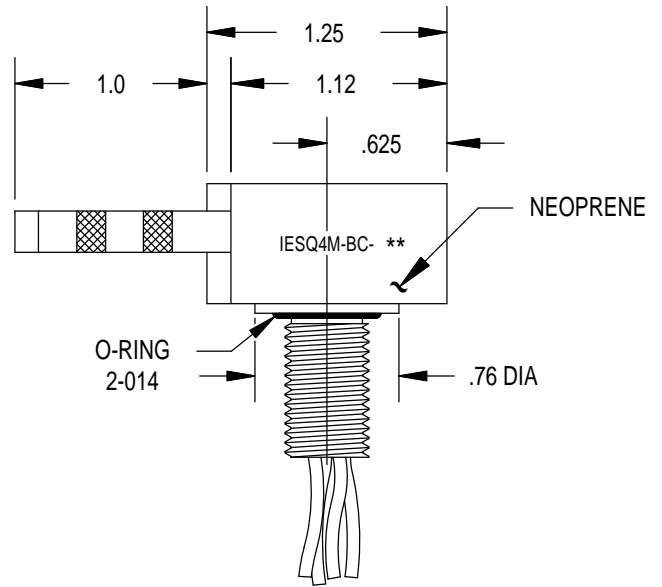
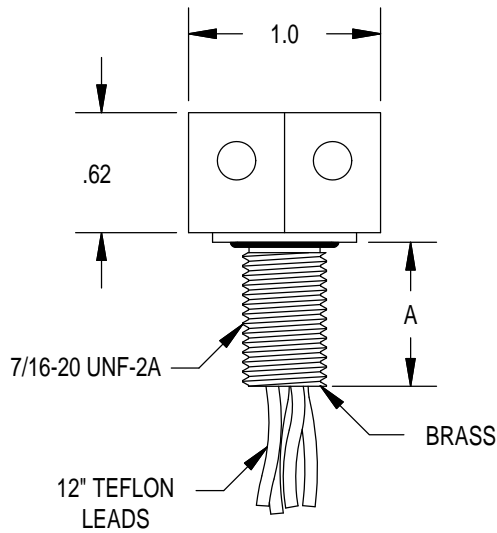

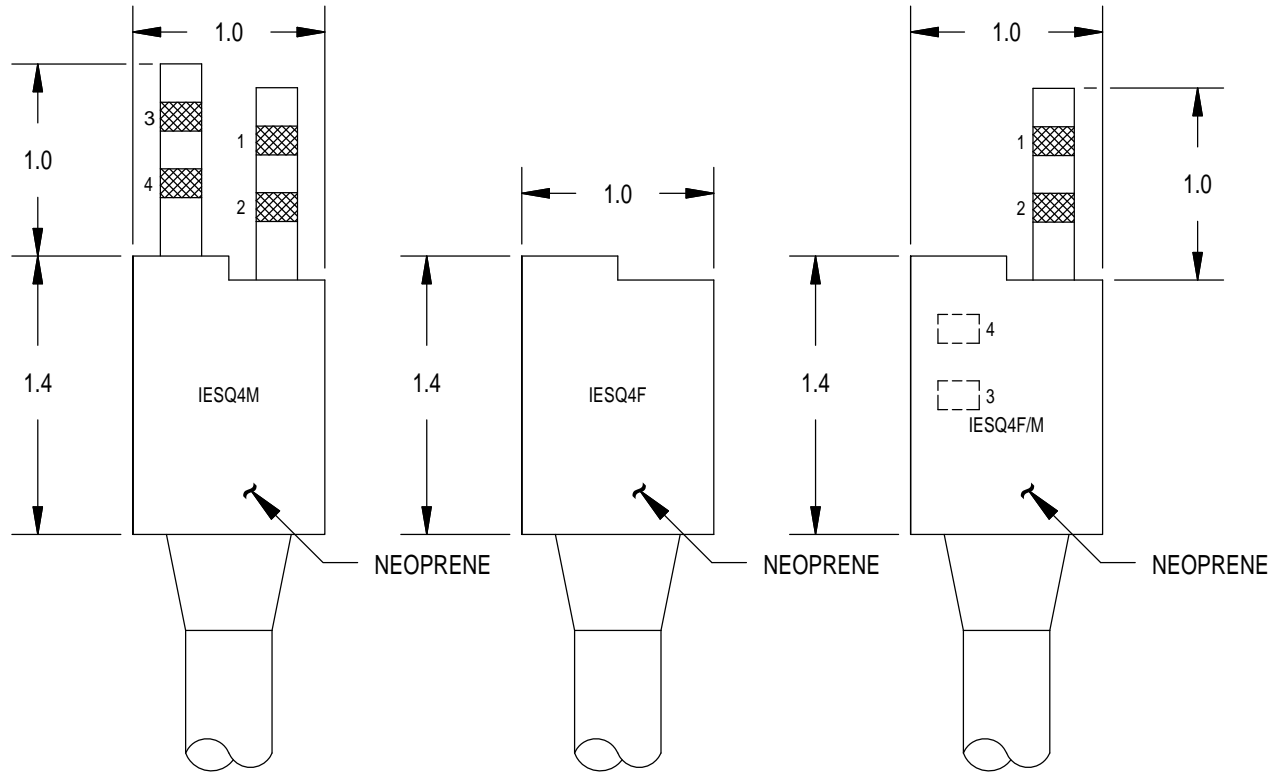

MOUNTING TORQUE FOR BC	not to exceed 100 in lbs
MATED PRESSURE RATING (psi)	5,000
DUMMY PLUG FOR IESQ4M-BC, IESQ4M	IESQ4F-DO *
DUMMY PLUG FOR IESQ4F-BC, IE2F	IESQ4M-DO *
DUMMY PLUG FOR IESQ4MF-BC, IESQ4F/M	IESQ4F/M-DO *
<p>* Dummy plugs found on Page 75 62. ** Shorted dummies available upon request. *** See chart for thread specifications. **** Specify M, F, F/M</p>	

BULKHEAD	
PART NUMBER	A
IESQ4****-BC-1	.50
IESQ4****-BC-2	.75
IESQ4****-BC-3	1.00

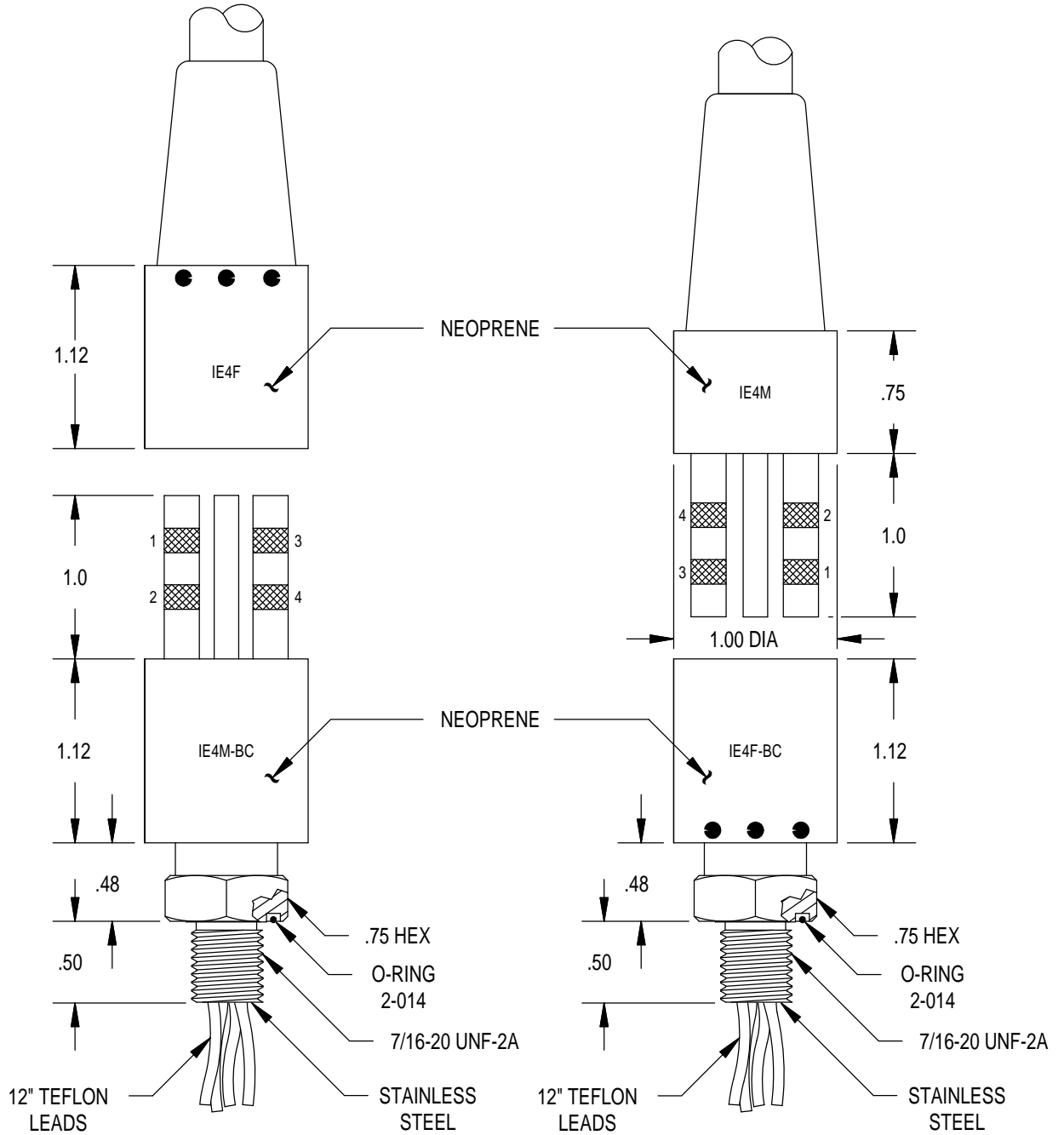

MOUNTING TORQUE FOR BC	not to exceed 100 in lbs
MATED PRESSURE RATING (psi)	10,000
DUMMY PLUG FOR IE4M-BC, IE4M	IE4F-DO *
DUMMY PLUG FOR IE4F-BC, IE4F	IE4M-DO *
* Dummied found on Page 75 63. ** Shorted dummies (DS) available upon request.	

CONTACT CONFIGURATION
(IE4M FACE VIEW)

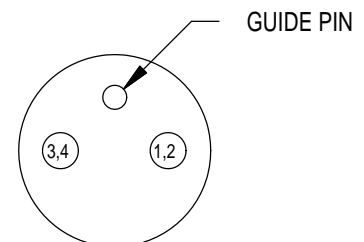

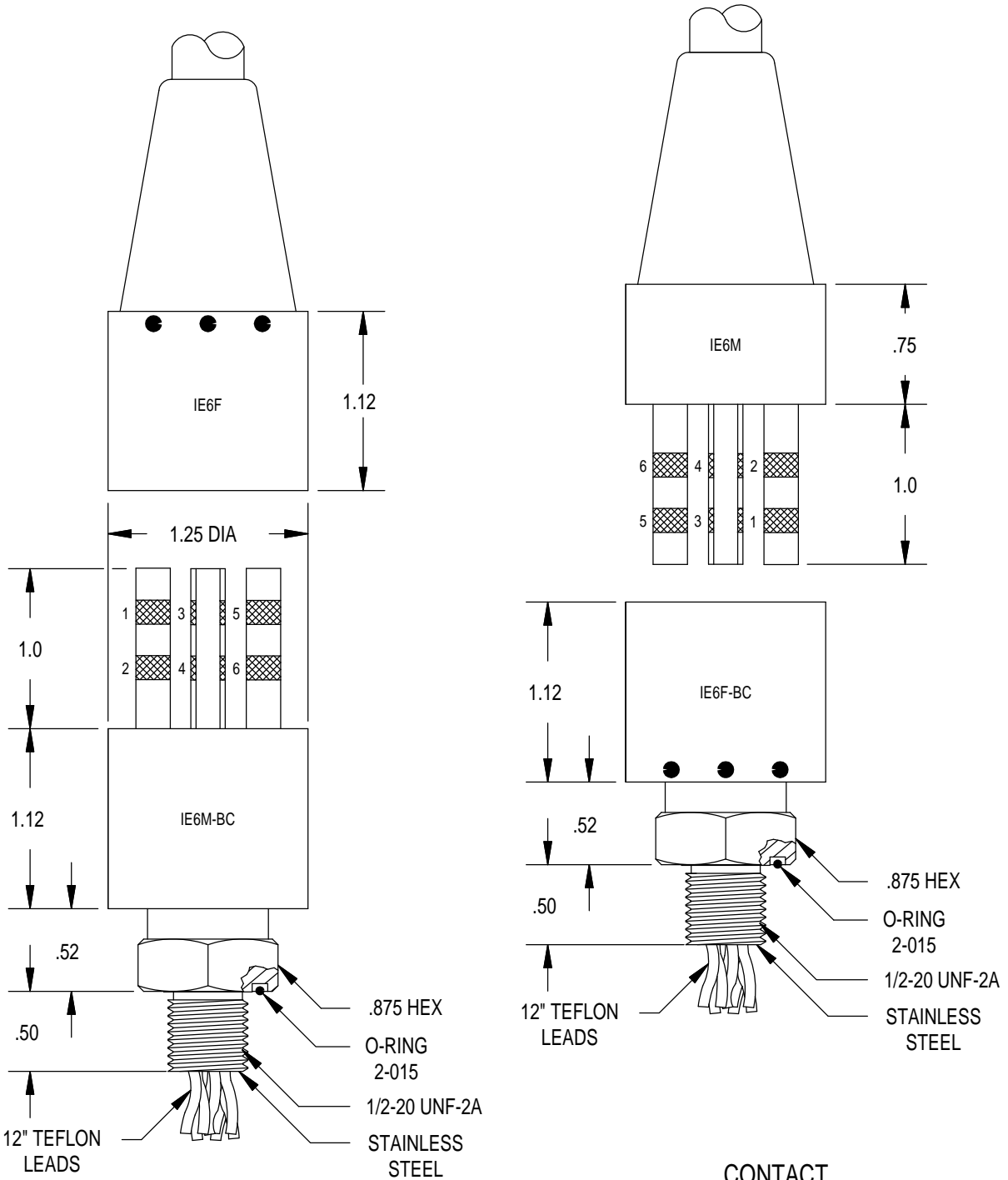

MOUNTING TORQUE FOR BC	not to exceed 100 in lbs
MATED PRESSURE RATING (psi)	10,000
DUMMY PLUG FOR IE6/8M-BC, IE6/8M	IE6/8F-DO *
DUMMY PLUG FOR IE6/8F-BC, IE6/8F	IE6/8M-DO *
* Dummy plugs found on Page 75 63. ** Shorted dummies (DS) available upon request.	

CONTACT CONFIGURATIONS
(IE6/8M FACE VIEWS)

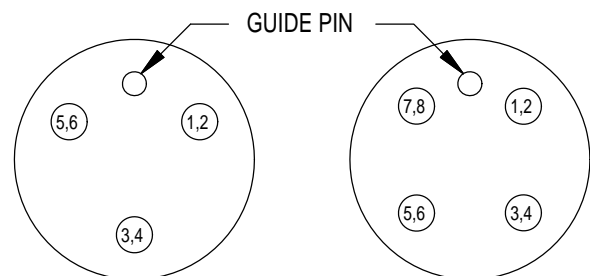

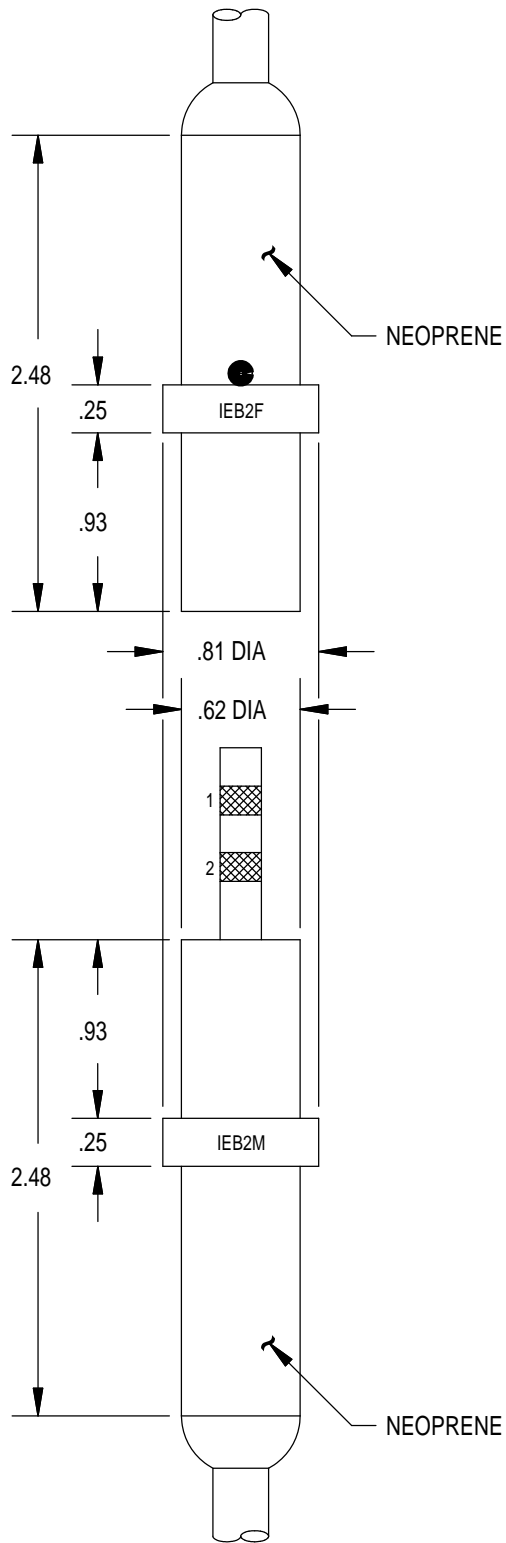

IEB2M FACE VIEW

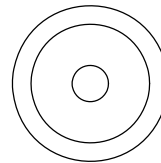

MATED PRESSURE RATING (psi)	10,000
DUMMY PLUG FOR IEB2M	IEB2F-DO *
DUMMY PLUG FOR IEB2F	IEB2M-DO *
* Dummy plugs found on Page 75 62. ** Shorted dummies (DS) available upon request.	

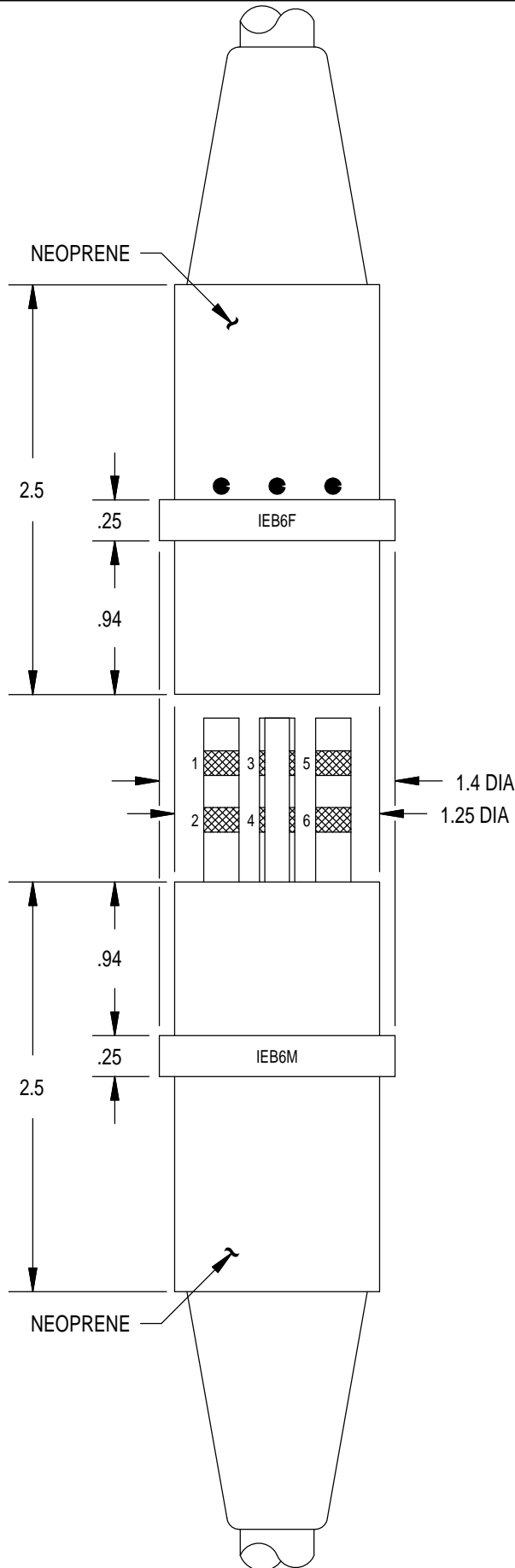

CONTACT CONFIGURATIONS
(IEB6/8M FACE VIEWS)

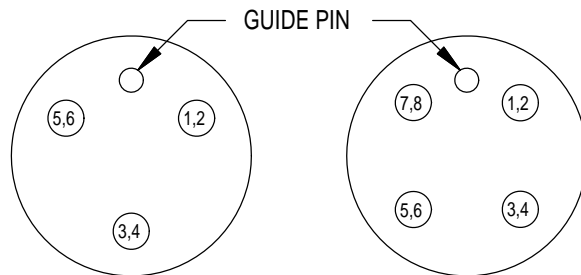

MATED PRESSURE RATING (psi)	10,000
DUMMY PLUG FOR IEB6/8M	IEB6/8F-DO *
DUMMY PLUG FOR IEB6/8F	IEB6/8M-DO *
<p>* Dummy plugs found on Page 75 63. ** Shorted dummies (DS) available upon request. *** Locking Sleeves found on Page 75 61.</p>	

DELTRIN LOCKING SLEEVES

MALE

6/8 CONTACT

FEMALE

IEB-6/8-MLS

IEB-6/8-FLS

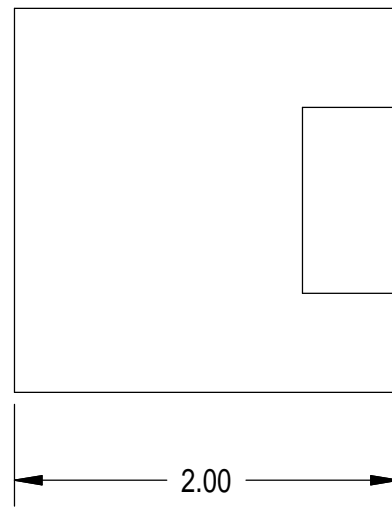
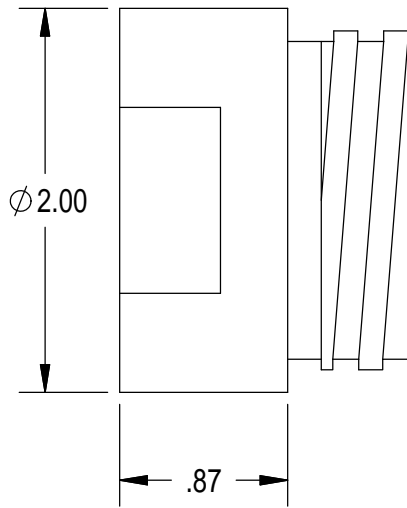

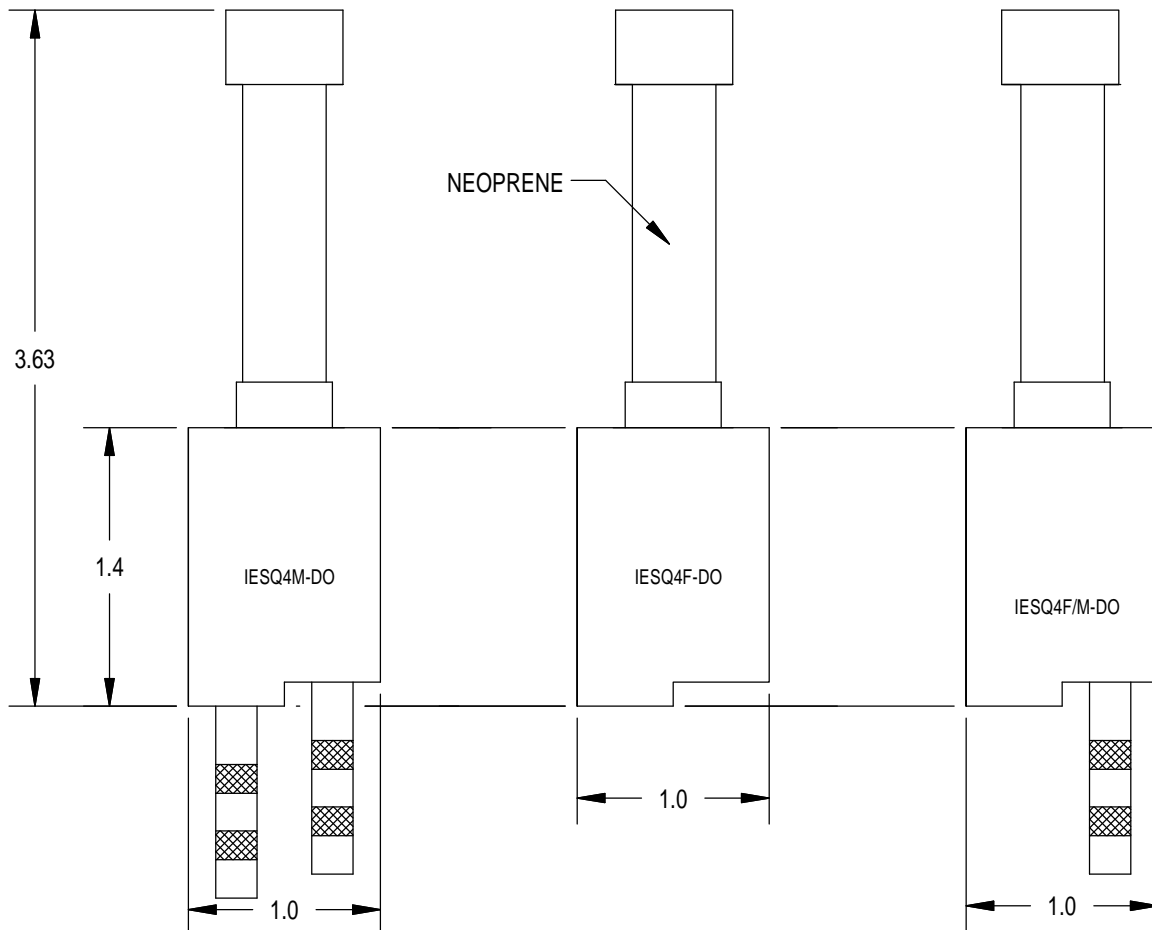
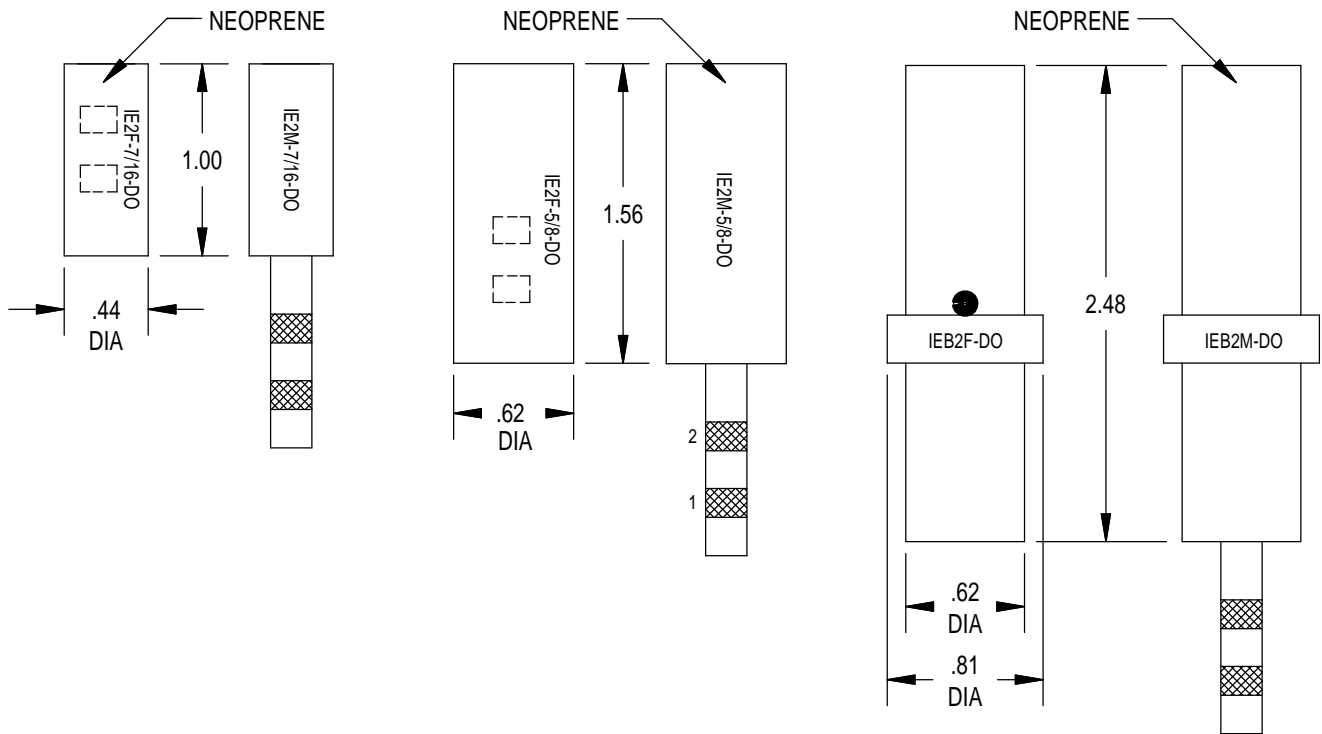

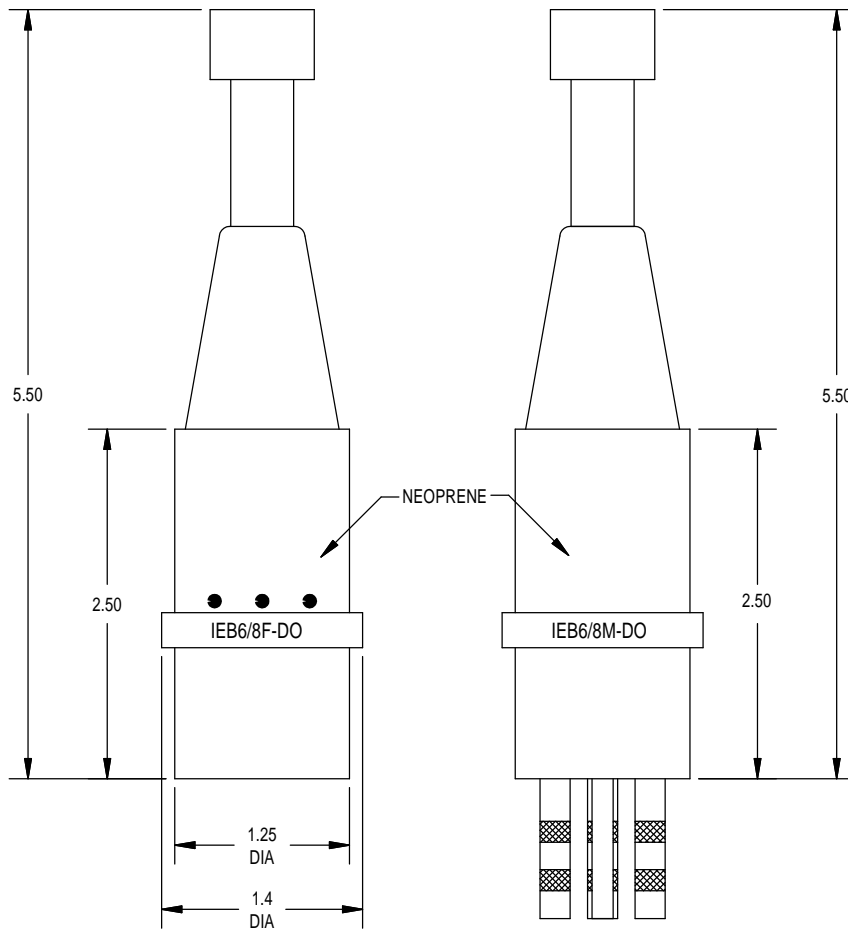
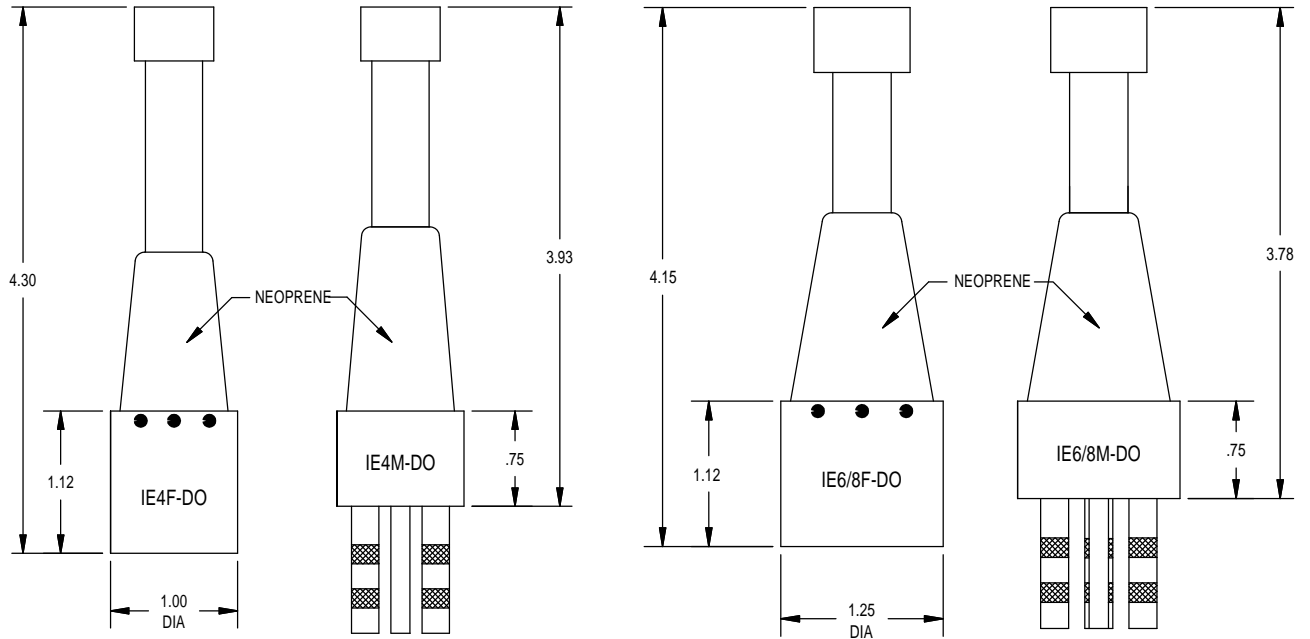

DESCRIPTION AND MATERIAL	<ul style="list-style-type: none">• Molded neoprene with improved sealing ability.• One to four contacts.• Up to 600 VDC, 10 AMPS.• Rated to 10,000 psi, contact factory for higher rating.• Bulkhead connector design open face pressure rated to 5000 PSI.• O-rings molded in female connector.
CABLE	<ul style="list-style-type: none">• Connectors in this series are molded on a 24" length of 16 AWG SO cable unless otherwise specified.• Bulkhead connectors have 12" teflon leads, Type E per MIL 16878/4 16 AWG, or 12" Belden 34416 leads (Neoprene jacket).
USES	<ul style="list-style-type: none">• Mates with other manufacturers connectors of same design.• Permits underwater plugging and unplugging with power off.• Light to heavy duty applications.• Hazardous environments.
GUIDELINES	<ul style="list-style-type: none">• All mounting surfaces require a 32 finish.• Lubricate male pins liberally with Dow Corning #111 Valve Lubricant or equivalent and apply a small amount in each hole of female socket. Connectors must be lubricated on a regular basis.• Lubricate o-rings with Dow Corning #111 Valve Lubricant or equivalent.• Replace o-rings when re-using connectors.• Align index pin prior to mating.• Avoid nicks and cuts around contacts as these are the sealing surfaces.• Elastomers can be seriously degraded if exposed to direct sunlight or high ozone levels for extended periods of time.• Do not over tighten bulkhead nuts.• Do not pull on cable to disconnect.• Avoid sharp bends at cable entry to connector.

IE31-BC

IE UNDERWATER PLUGGABLE SERIES 3

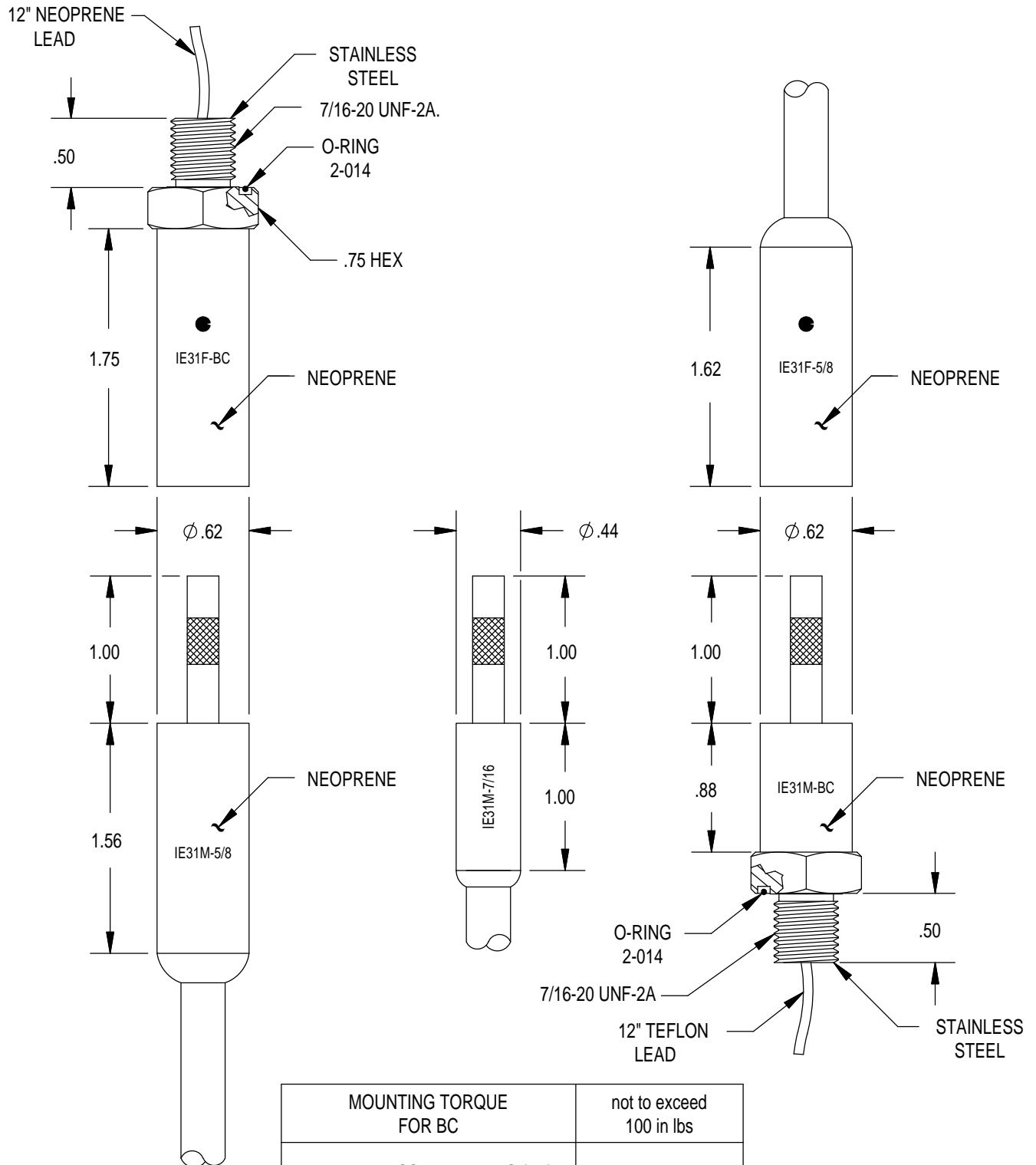

MOUNTING TORQUE FOR BC	not to exceed 100 in lbs
MATED PRESSURE RATING (psi)	10,000
DUMMY PLUG FOR IE31M-5/8, IE31M-BC	IE31F-5/8-DO *
DUMMY PLUG FOR IE31F-BC, IE31F-5/8	IE31M-5/8-DO *
* Dummy plugs found on Page 75 110	
** Shorted dummies (DS) available upon request	

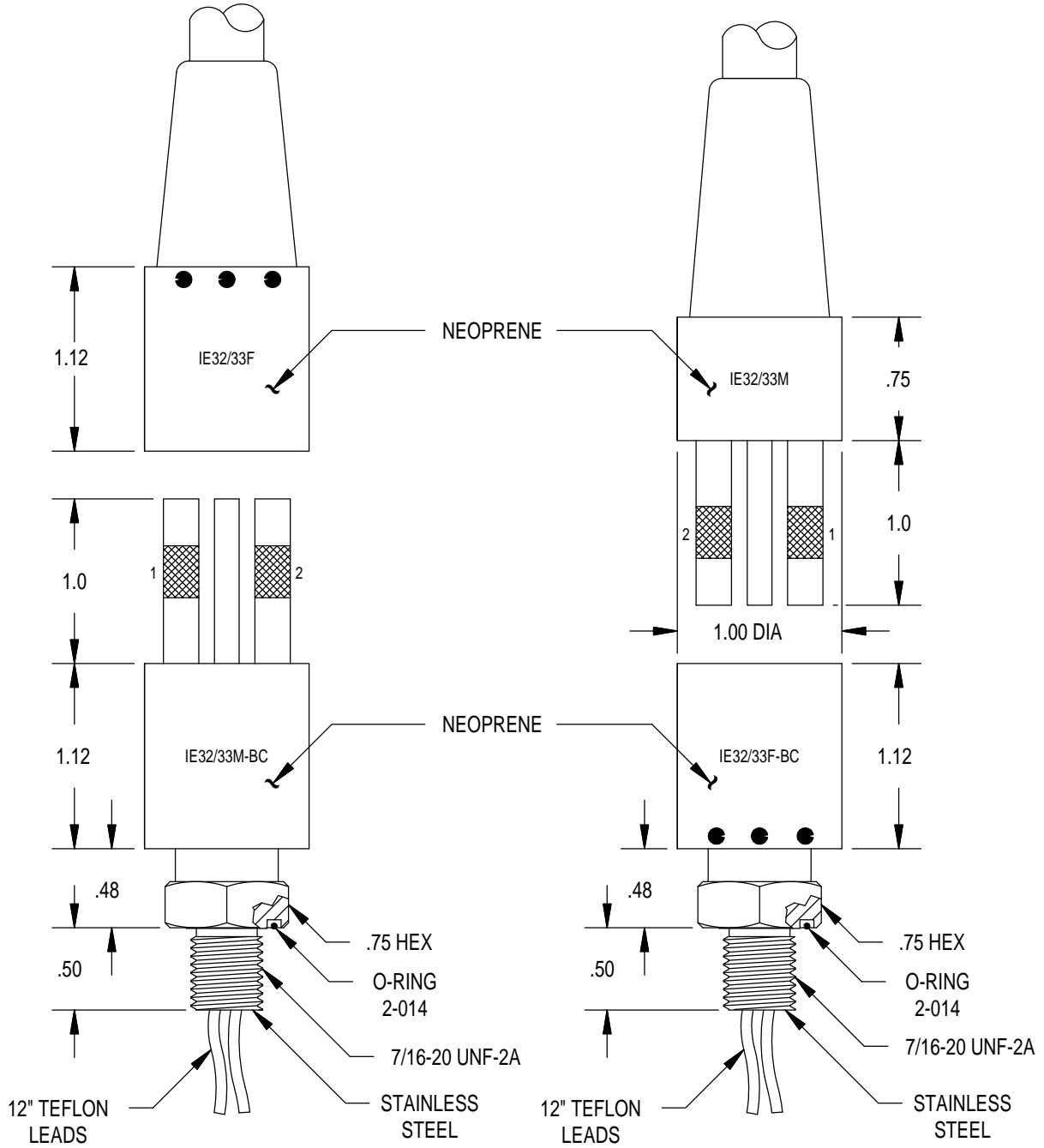

**CONTACT
CONFIGURATION**
(BC FACE VIEWS)

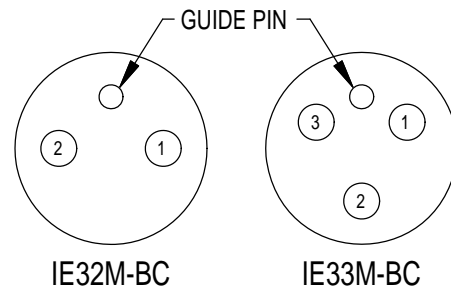

MOUNTING TORQUE FOR BC	not to exceed 100 in lbs
MATED PRESSURE RATING (psi)	10,000
DUMMY PLUG FOR IE32/33M-BC, IE32/33M	IE32/33F-DO *
DUMMY PLUG FOR IE32/33F-BC, IE32/33F	IE32/33M-DO *
* Dummy plugs found on Page 75 110. ** Shorted dummies (DS) available upon request	

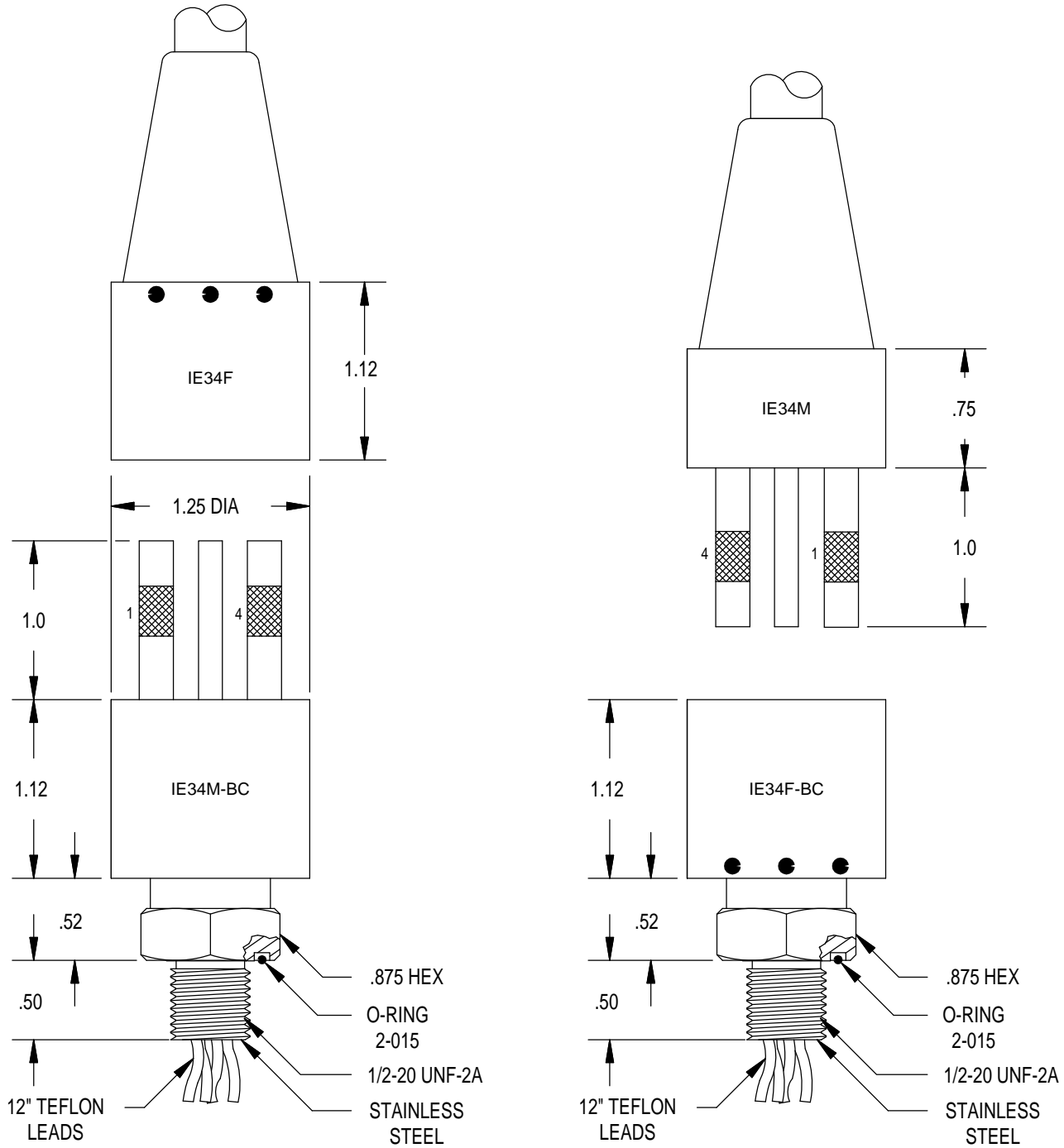

MOUNTING TORQUE FOR BC	not to exceed 100 in lbs
MATED PRESSURE RATING (psi)	10,000
DUMMY PLUG FOR IE34M-BC, IE34M	IE34F-DO *
DUMMY PLUG FOR IE34F-BC, IE34F	IE34M-DO *
* Dummy plugs found on Page 75 111. ** Shorted dummies (DS) available upon request.	

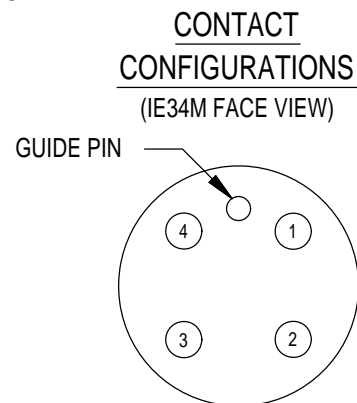

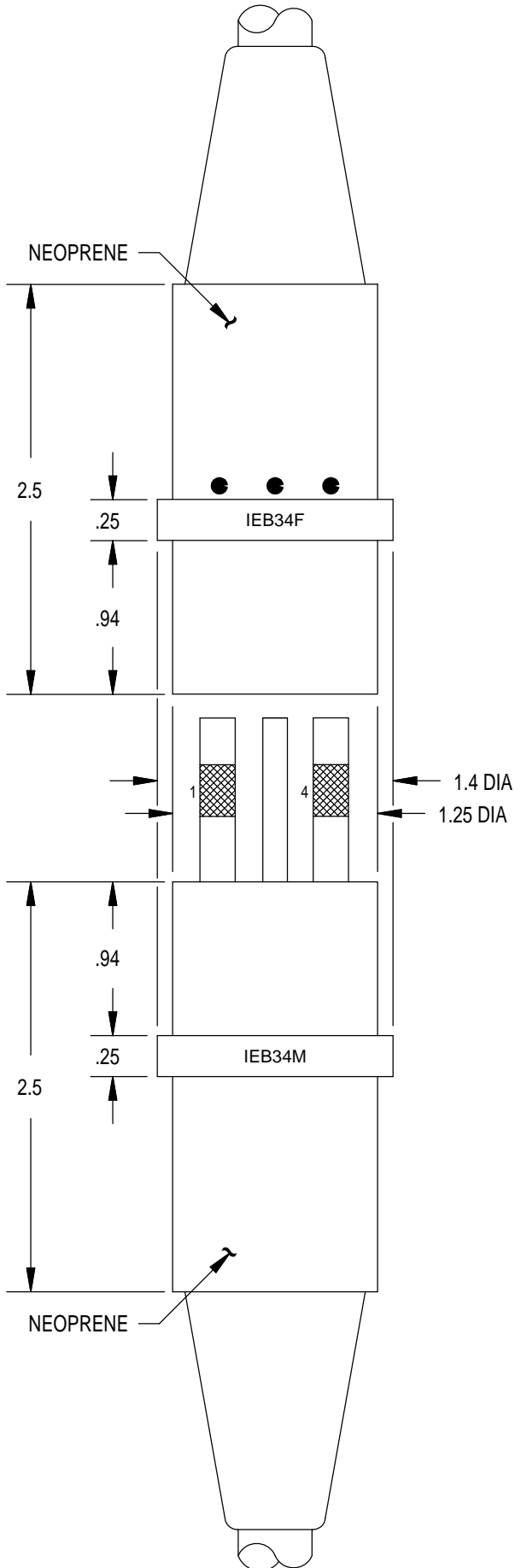

CONTACT
CONFIGURATIONS
(IEB34M FACE VIEW)

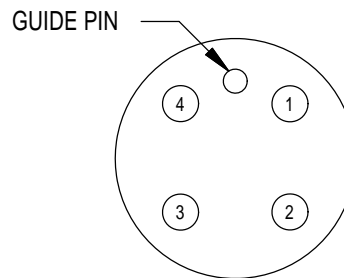

MATED PRESSURE RATING (psi)	20,000
DUMMY PLUG FOR IEB34M	IEB34F-DO *
DUMMY PLUG FOR IEB34F	IEB34M-DO *
* Dummy plugs found on Page 75 111. ** Shorted dummies (DS) available upon request.	

IESQ32-BC

IE UNDERWATER
PLUGGABLE SERIES 3

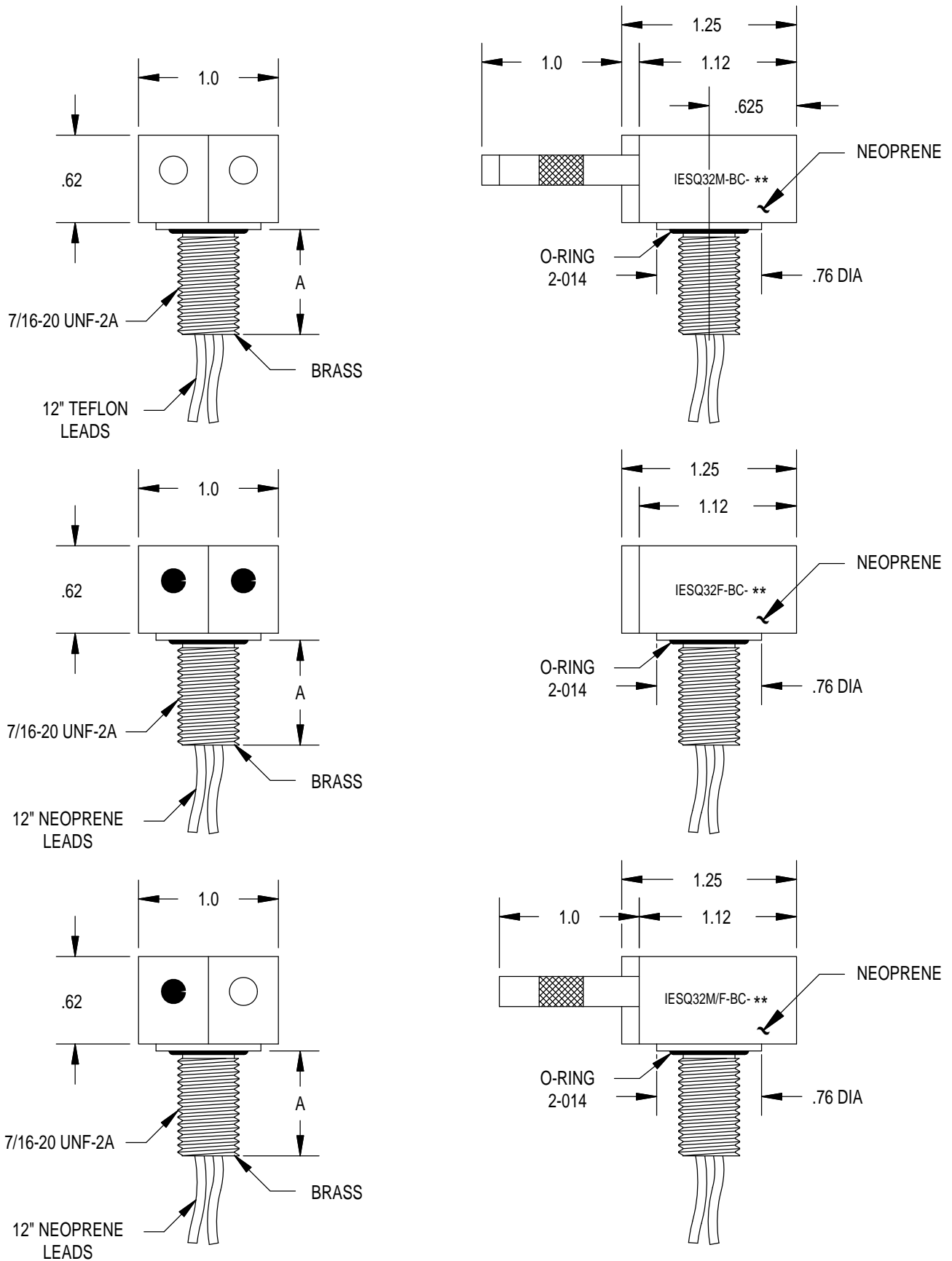

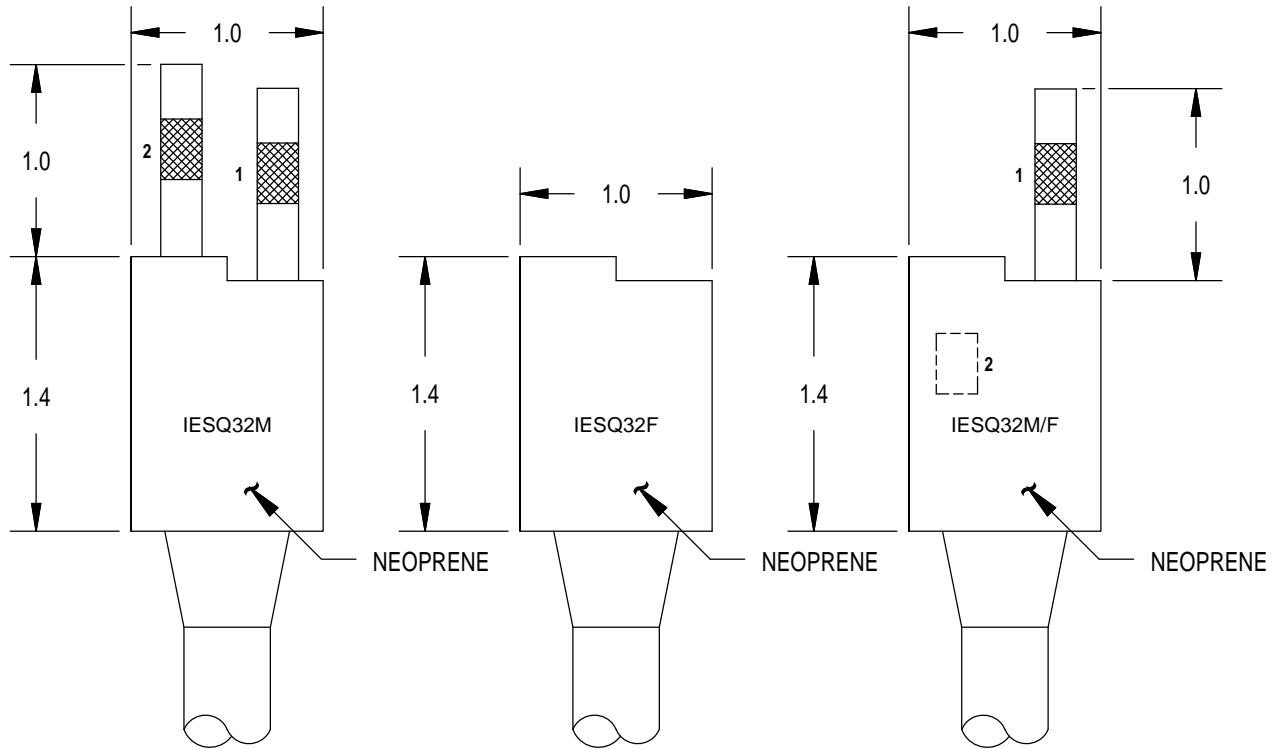

MOUNTING TORQUE FOR BC	not to exceed 100 in lbs
MATED PRESSURE RATING (psi)	5,000
DUMMY PLUG FOR IESQ32M-BC, IESQ32M	IESQ32F-DO *
DUMMY PLUG FOR IESQ32F-BC, IESQ32F	IESQ32M-DO *
DUMMY PLUG FOR IESQ32M/F-BC, IESQ32M/F	IESQ32M/F-DO *
<p>* Dummy plugs found on Page 75 112. ** Shorted dummies available upon request. *** See chart for thread specifications. **** Specify M/F/MF</p>	

BULKHEAD	
PART NUMBER	A
IESQ32 **** -BC-1	.50
IESQ32 **** -BC-2	.75
IESQ32 **** -BC-3	1.00

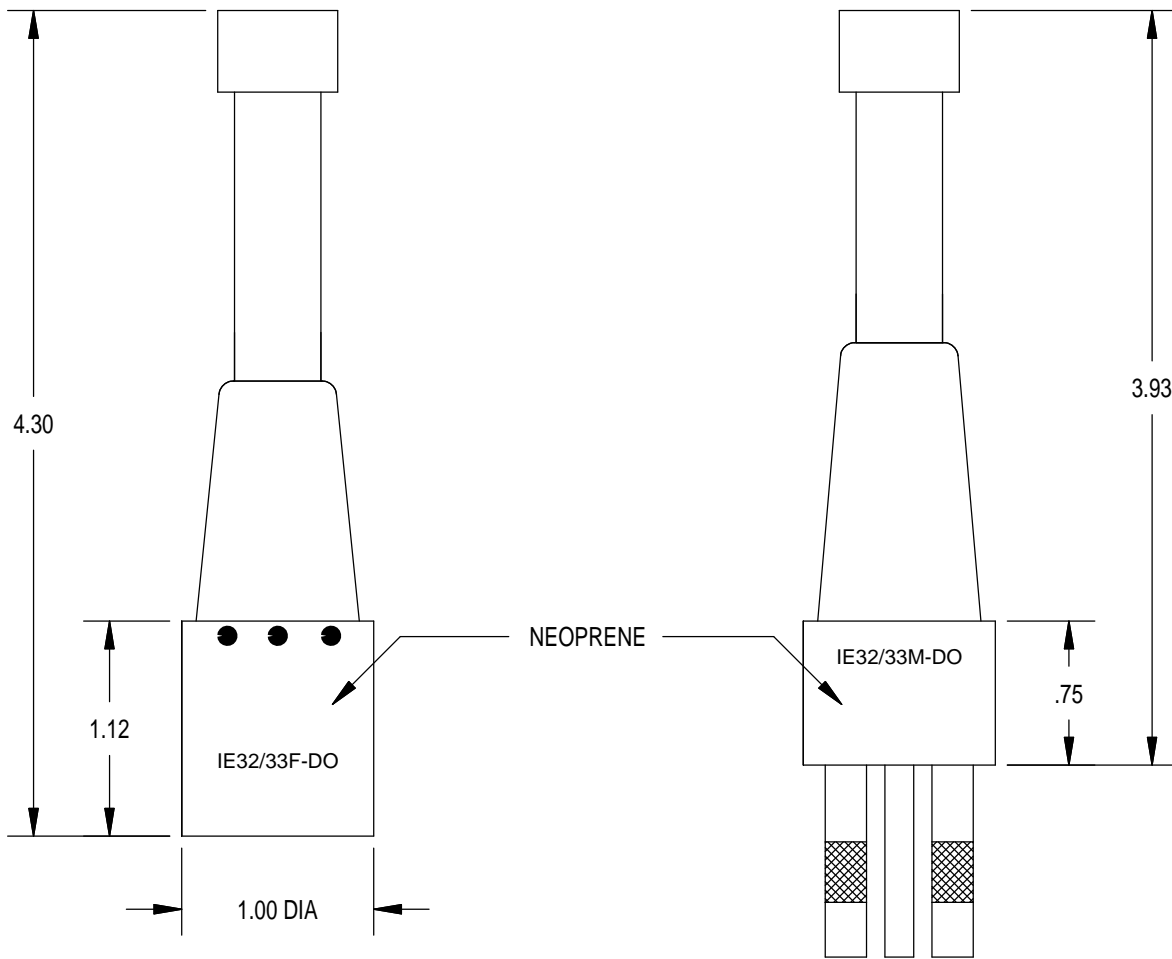
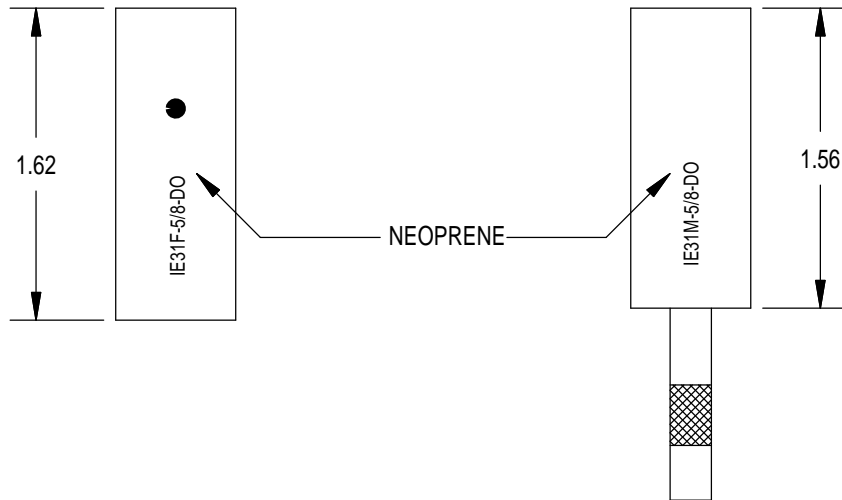

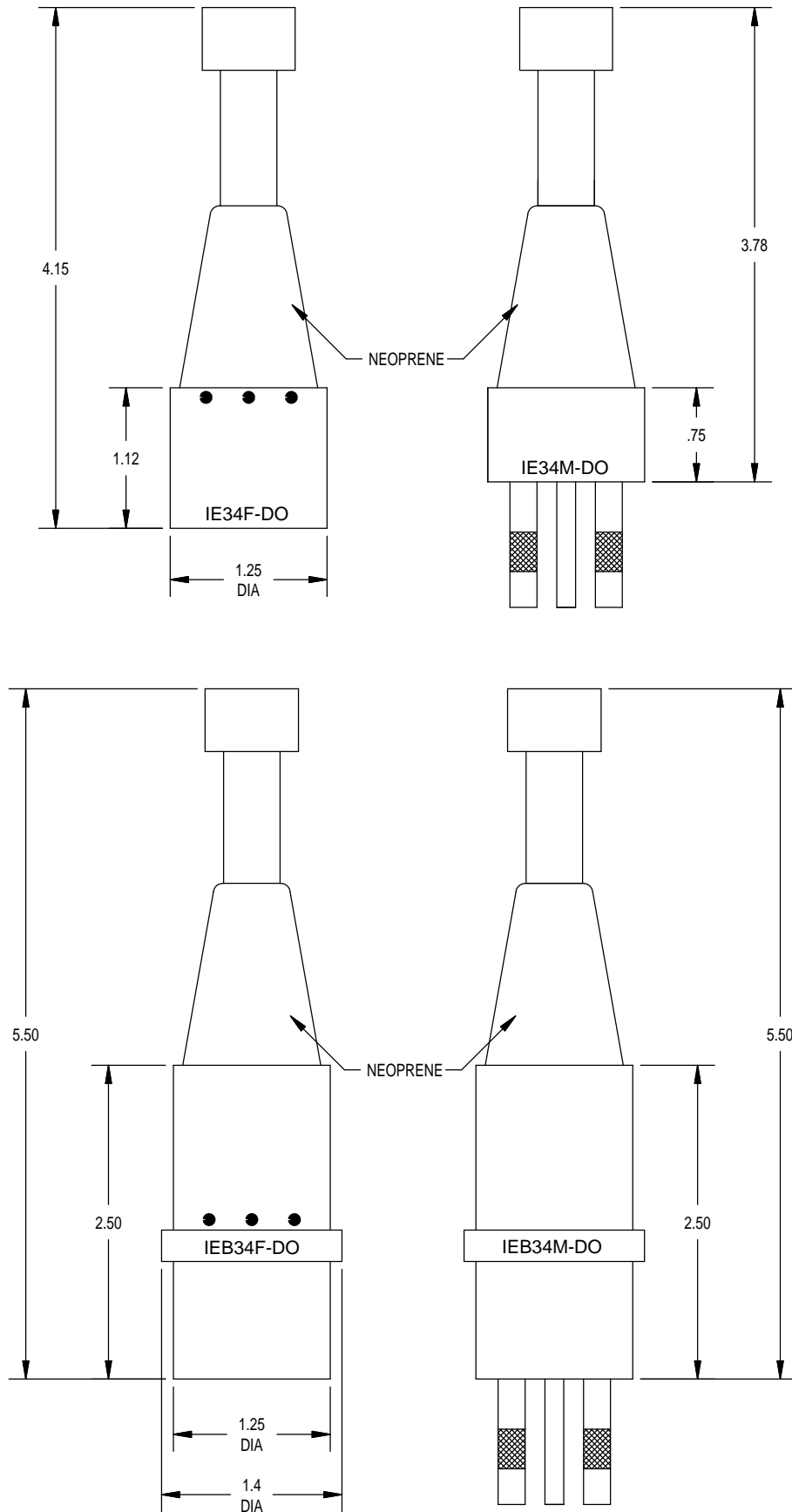

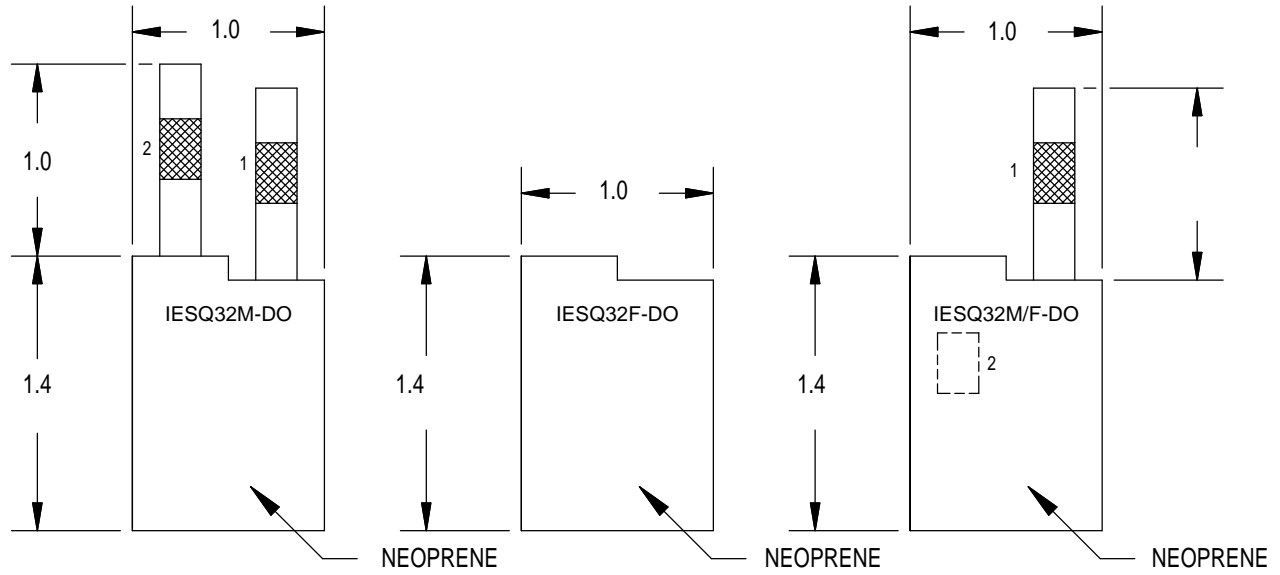

DESCRIPTION AND MATERIAL	<ul style="list-style-type: none">• Molded neoprene.• Up to 200 VDC.• Up to 5,000 PSI.• Bulkhead switch design open face pressure rated to 5000 PSI.• Switches are normally open.
CABLE	<ul style="list-style-type: none">• Connectors in this series are molded on a standard 24" length of SO cable.
USES	<ul style="list-style-type: none">• Current meters.• Safety devices.• Device monitoring.• Light to heavy duty applications.• Hazardous environments.
GUIDELINES	<ul style="list-style-type: none">• All mounting surfaces require a 32 finish.• Lubricate mating surfaces of RSBH/RSIL with 3M Silicone Spray or equivalent, DO NOT grease! Connectors must be lubricated on a regular bases.• Lubricate male pin of IE2M-7/16 liberally with Dow Corning #111 Valve Lubricant or equivalent and apply a small amount in the female socket. Connectors must be lubricated on a regular basis.• Lubricate o-rings with Dow Corning #111 Valve Lubricant or equivalent.• Avoid nicks and cuts around contacts as these are the sealing surfaces.• Elastomers can be seriously degraded if exposed to direct sunlight or high ozone levels for extended periods of time.• Do not over tighten bulkhead nuts.• Do not pull on cable to disconnect.• Avoid sharp bends at cable entry to connector.
ORDERING INFORMATION	<ul style="list-style-type: none">• Bulkhead connectors do not come with nuts and washers. If required, please specify when ordering.

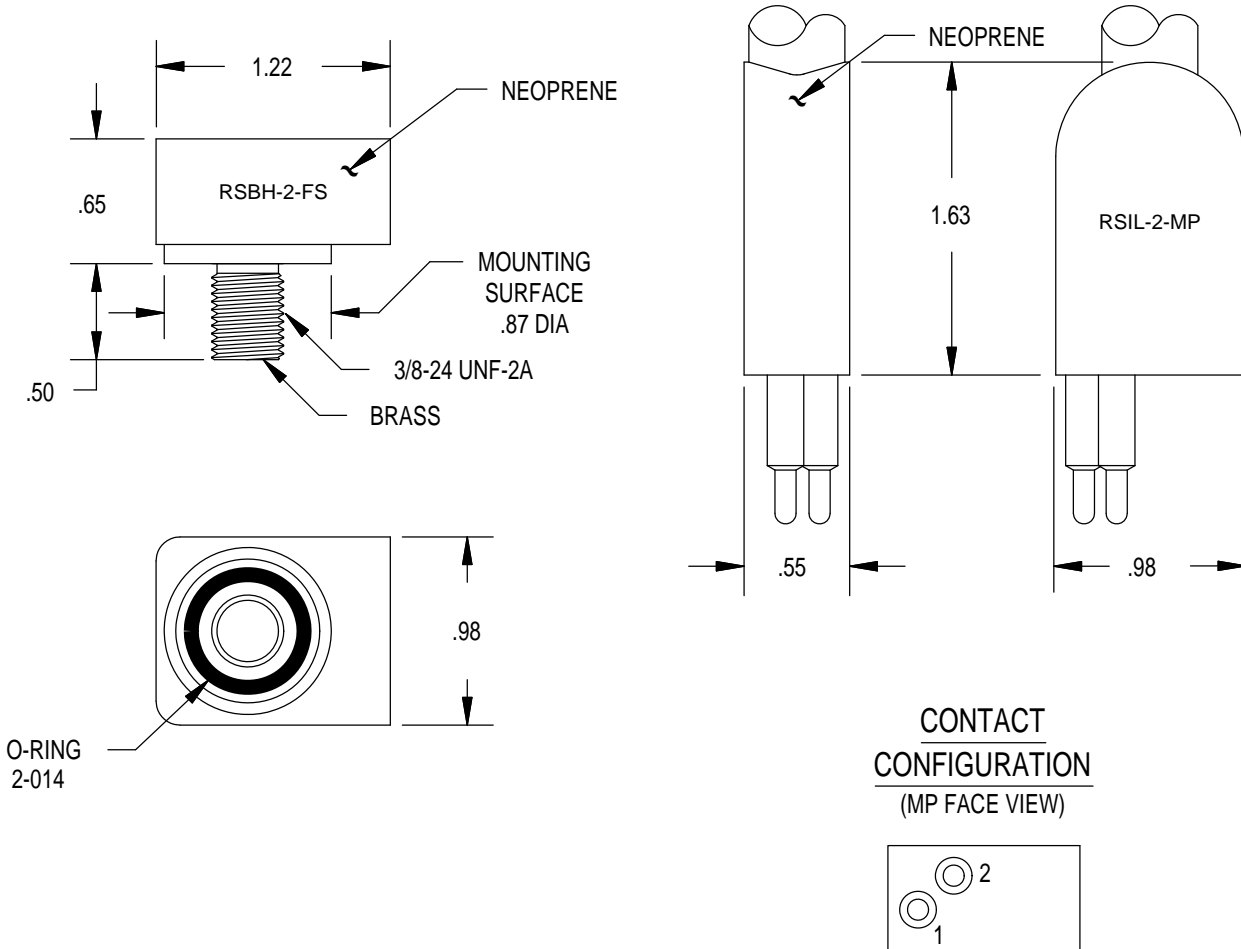

SWITCH RATINGS		CONNECTOR RATINGS	
CURRENT	0.5 A	MOUNTING TORQUE	not to exceed 100 in lbs
VOLTAGE	200VDC	MATED PRESSURE RATING (psi)	5,000
RESISTANCE	0.100 OHM	DUMMY PLUG FOR RSBH-2-FS	RSDC-2-MP
OPERATING TIME (MAX)	0.6 mS	DUMMY PLUG FOR RSIL-2-MP	RSDC-2-FS
RELEASE TIME (MAX)	0.1 mS		
<p>NOTE: Bulkhead available in stainless steel. Standard 1/2" thread length. Bulkhead available with inboard leads + mating connector or inboard leads without mating connector.</p>			

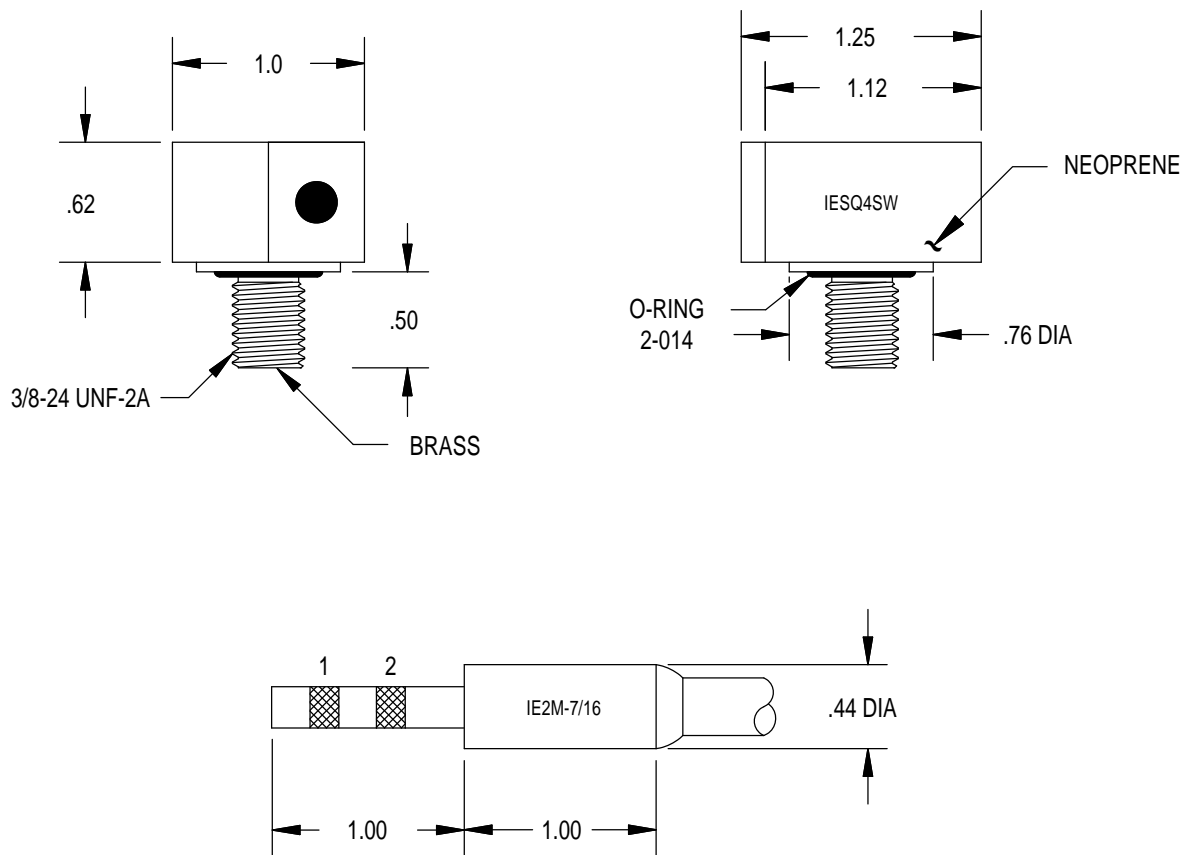

SWITCH RATINGS		CONNECTOR RATINGS	
CURRENT	0.5 A	MOUNTING TORQUE	not to exceed 100 in lbs
VOLTAGE	200VDC	MATED PRESSURE RATING (psi)	5,000
RESISTANCE	0.100 OHM	DUMMY PLUG FOR IESQ4SW	IE2M-7/16-DO *
OPERATING TIME (MAX)	0.6 mS	DUMMY PLUG FOR IE2M-7/16	IE2F-7/16-DO *
RELEASE TIME (MAX)	0.1 mS		

NOTE: Bulkhead available in stainless steel.
Standard 1/2" thread length.
Bulkhead available with inboard leads + mating connector or inboard leads without mating connector.
* Shorted dummies (DS) available upon request.

THIS PAGE INTENTIONALLY LEFT BLANK

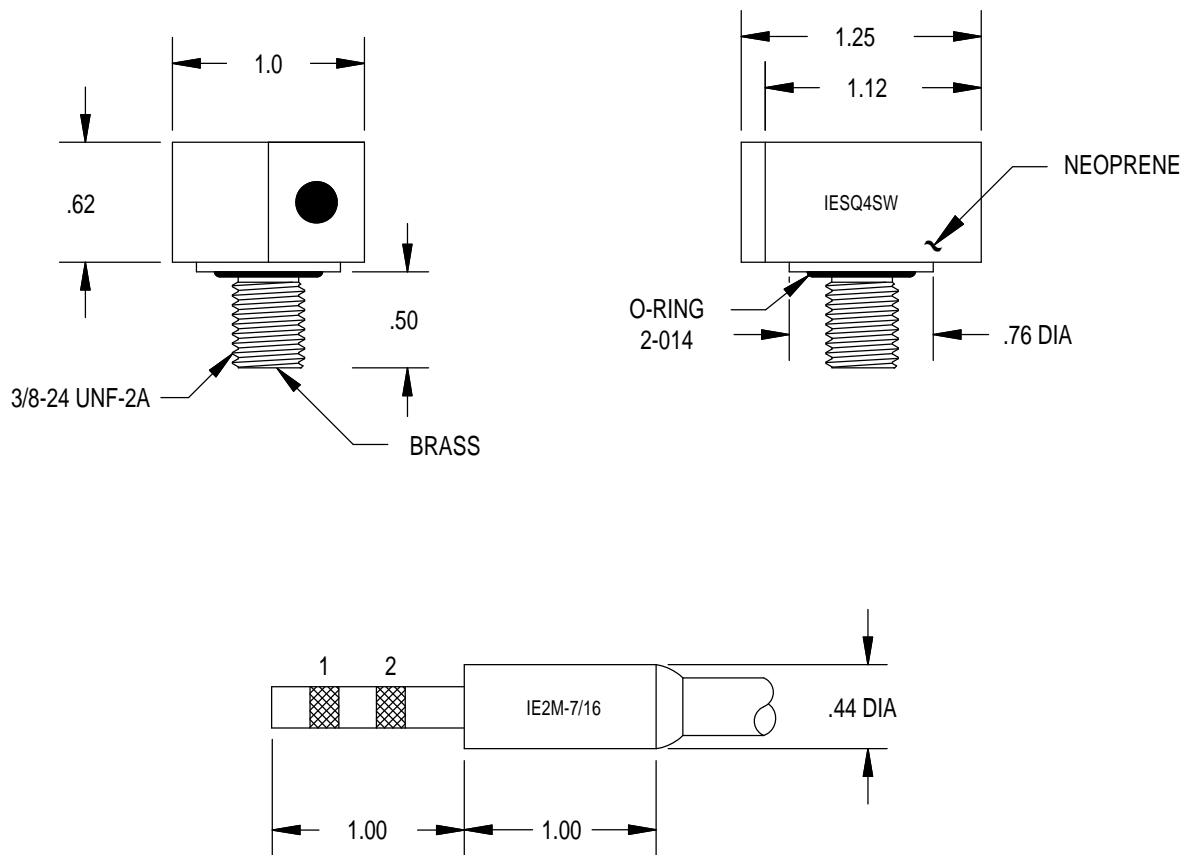

SWITCH RATINGS		CONNECTOR RATINGS	
CURRENT	0.5 A	MOUNTING TORQUE	not to exceed 100 in lbs
VOLTAGE	200VDC	MATED PRESSURE RATING (psi)	5,000
RESISTANCE	0.100 OHM	DUMMY PLUG FOR IESQ4SW	IE2M-7/16-DO *
OPERATING TIME (MAX)	0.6 mS	DUMMY PLUG FOR IE2M-7/16	IE2F-7/16-DO *
RELEASE TIME (MAX)	0.1 mS		

NOTE: Bulkhead available in stainless steel.
Standard 1/2" thread length.
Bulkhead available with inboard leads + mating connector or inboard leads without mating connector.
* Shorted dummies (DS) available upon request.

THIS PAGE INTENTIONALLY LEFT BLANK

MINIATURE HIGH DENSITY SERIES

- DESCRIPTION AND MATERIAL**
- 316 stainless steel passivated per QQ-P-35 Type VI with naval bronze engaging nut.
 - Special alloys are available upon request (contact factory).
 - Contains a removable glass reinforced epoxy insert.
(Except for MHDG series and CCP's)
 - Up to 96 contacts.
 - Up to 600 VDC.
 - 10,000 PSI in mated condition (higher pressure rating available using special alloy metal shell; please contact factory).
 - Bulkhead connector design open face pressure rated to 5,000 psi.
 - MHD-CCR/CCP connectors can be overmolded with polyurethane.
 - Contacts are gold plated per MIL-G-45204.
- CABLE**
- Connector's amperage and voltage may be limited by the amperage and voltage ratings of the cable to which the connector is molded.
 - This series is not molded to cable unless specified at the time of order.
- USES**
- Signal telemetry.
 - Hazardous environment.
 - FCR is mounted by use of four equally spaced bolts around the flange surface.
 - FCR is used in place of the BCR when the use of a bulkhead nut and washer is impractical.
 - For all open face pressures above 5,000 PSI the BCR, FCR must be back potted (please contact the factory).
 - The CCR is used in a variety of environments where cable to cable termination is necessary.
- GUIDELINES**
- Mounting torque should not exceed 150 in lbs. for this series.
 - All mounting surfaces require a 32 finish.
 - Align indexes.
 - Keep o-ring grooves clean.
 - Avoid o-ring cuts and nicks.
 - Lubricate o-rings with Dow Corning #111 Valve Lubricant or equivalent.
 - Replace o-rings when re-using connectors.
 - Avoid contact with noxious solvents.
 - Elastomers can be seriously degraded if exposed to direct sunlight or high ozone levels for extended periods of time.

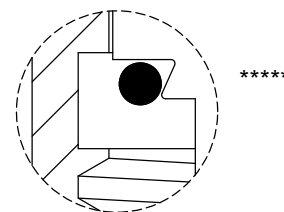
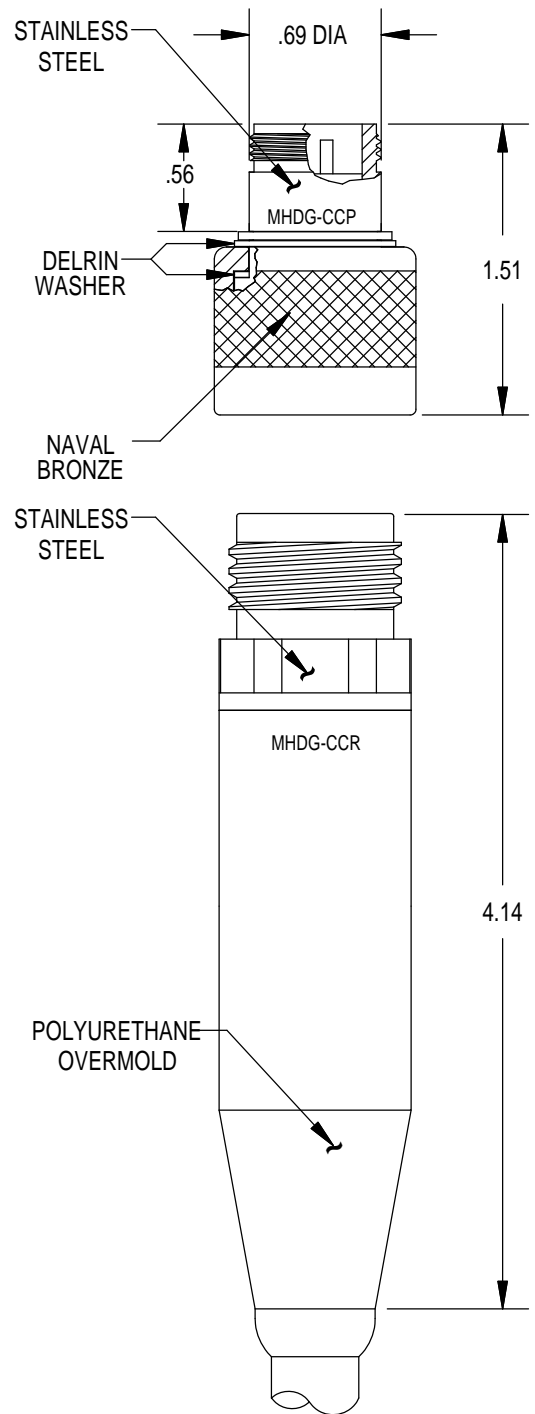
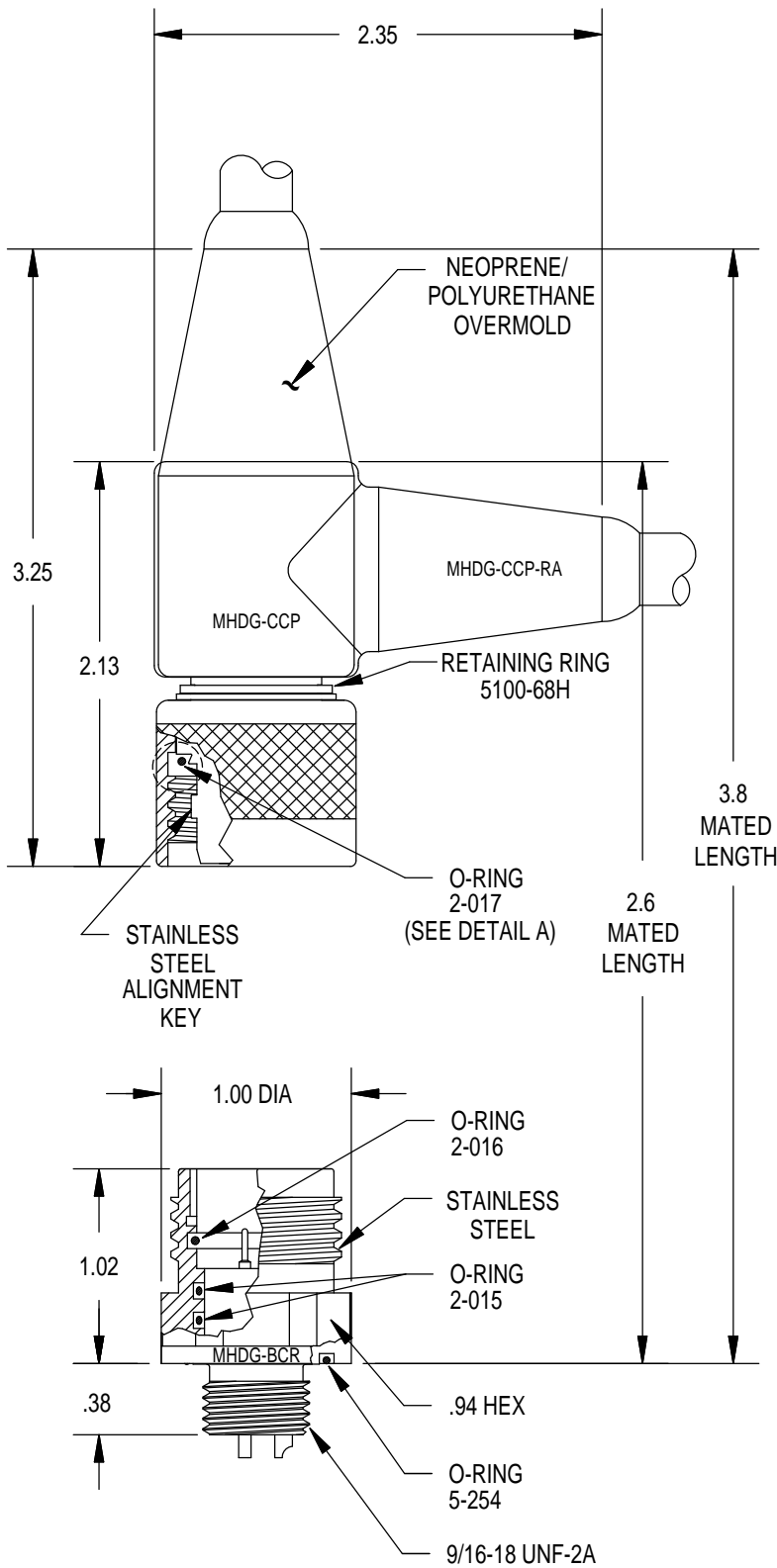

DETAIL A

CONTACT CONFIGURATION
(BCR FACE VIEW)

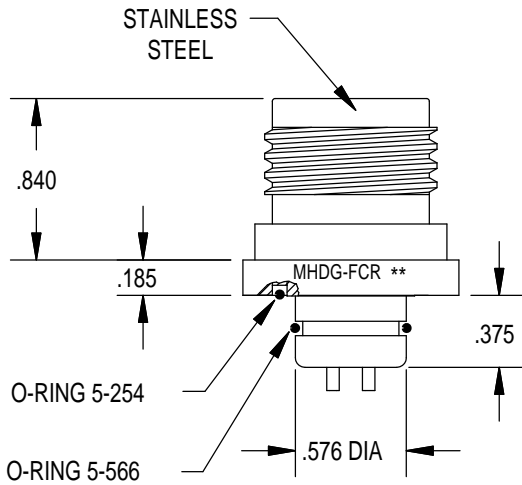
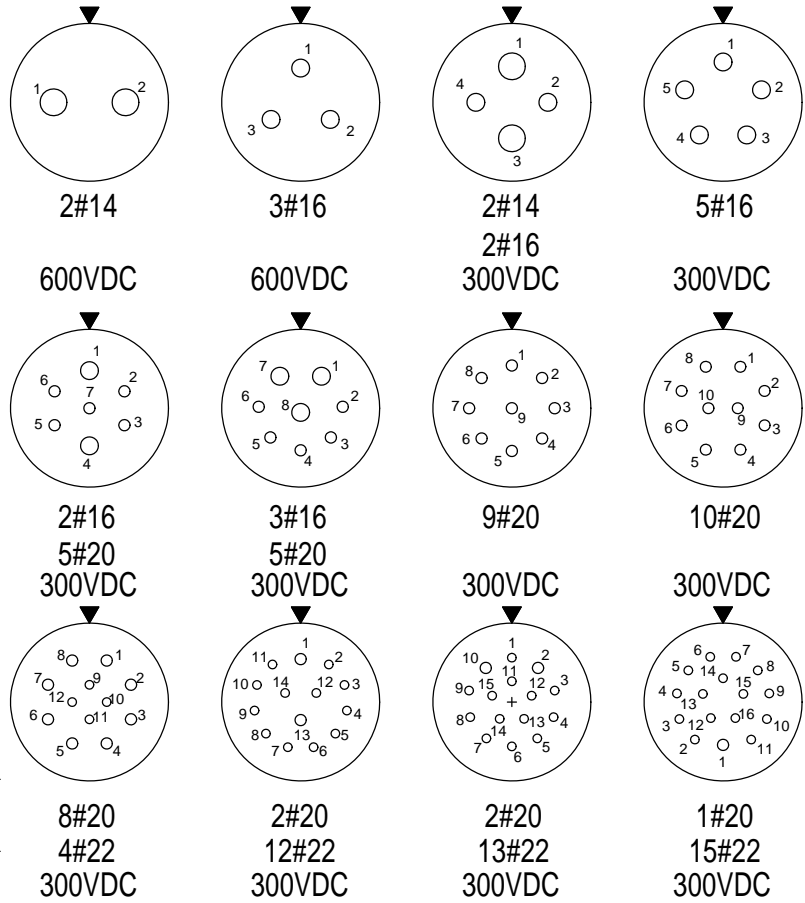
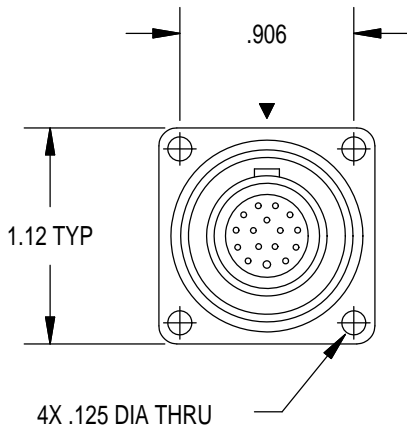

MOUNTING INSTRUCTIONS

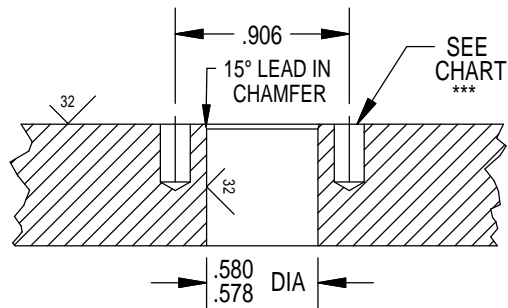

MOUNTING TORQUE FOR MHDG-BCR	not to exceed 150 in lbs	MATED PRESSURE RATING (psi)	10,000
DUMMY PLUG FOR MHDG-BCR/FCR/CCR	MHDG-SCP	DUMMY PLUG FOR MHDG-CCP	MHDG-SCR

NOTE: CCP is not terminated to cable unless specified.

* Please specify number of contacts.

** Internal assembly same as MHDG-BCR (facing page).

*** Blind tapped hole not to penetrate bulkhead, minimum full thread depth 2 times bolt diameter.

**** Oil filled version available. See section 86.

***** O-Ring installation tool available - Contact factory for further details.

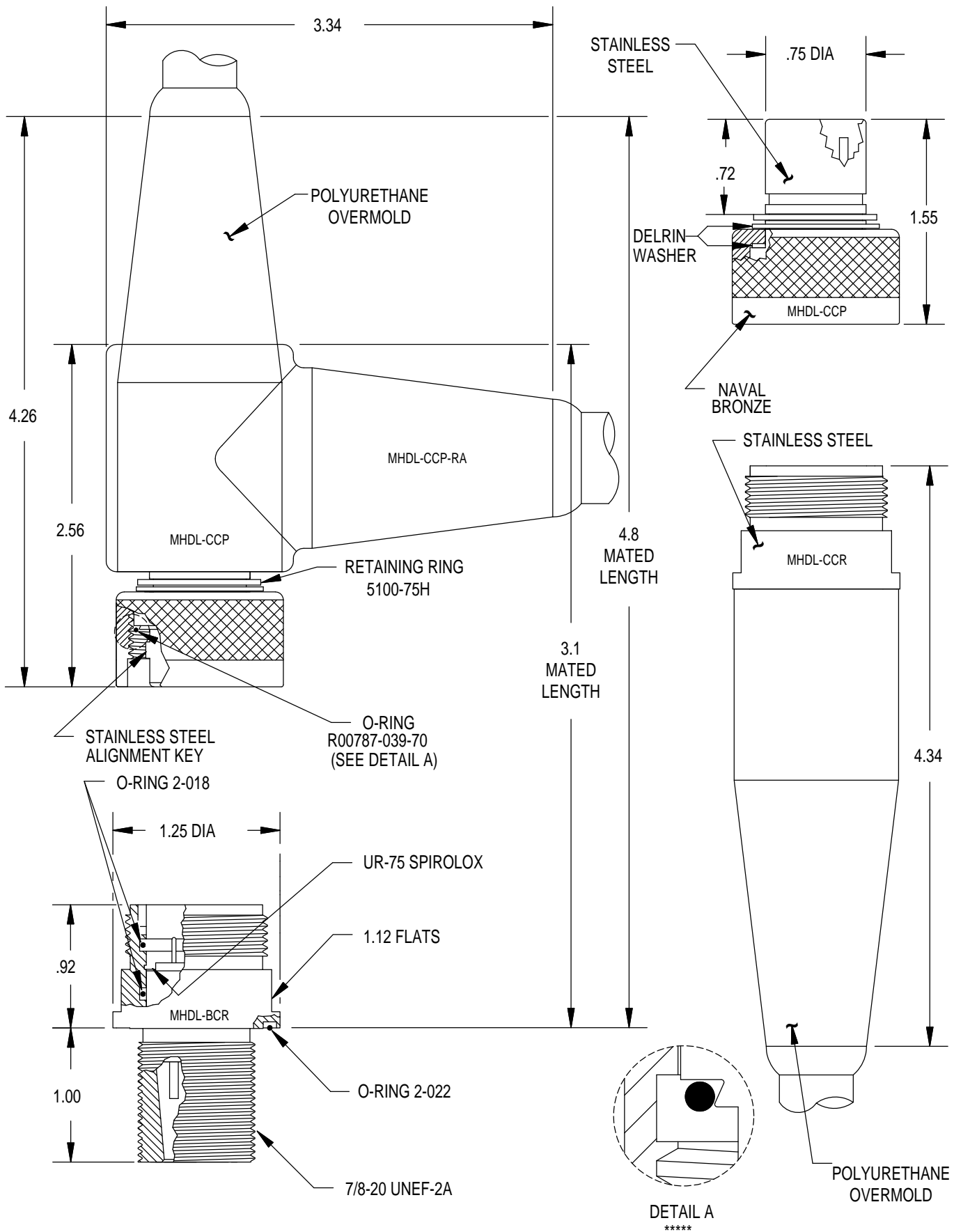

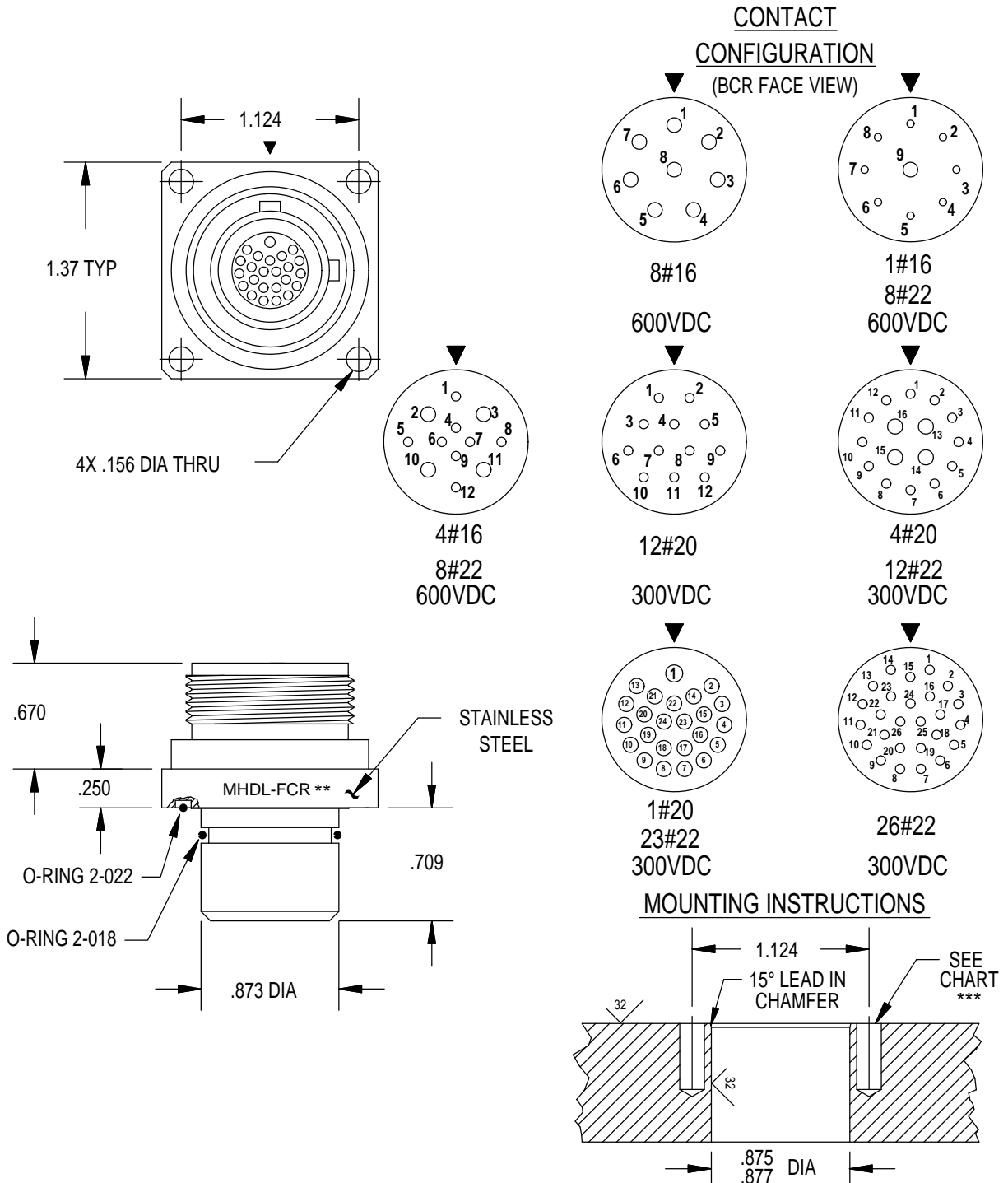

MOUNTING TORQUE FOR MHDLC-BCR	not to exceed 200 in lbs	MATED PRESSURE RATING (psi)	10,000
DUMMY PLUG FOR MHDLC-BCR/FCR/CCR	MHDLC-SCP	DUMMY PLUG FOR MHDLC-CCP	MHDLC-SCR

NOTE: CCP is not terminated to cable unless specified.
 * Please specify number of contacts.
 ** Internal assembly same as MHDLC-BCR (facing page).
 *** Blind tapped hole not to penetrate bulkhead, minimum full thread depth 2 times bolt diameter.
 **** Oil filled version available upon request. See section 86.
 ***** O-Ring installation tool available - Contact factory for further details.

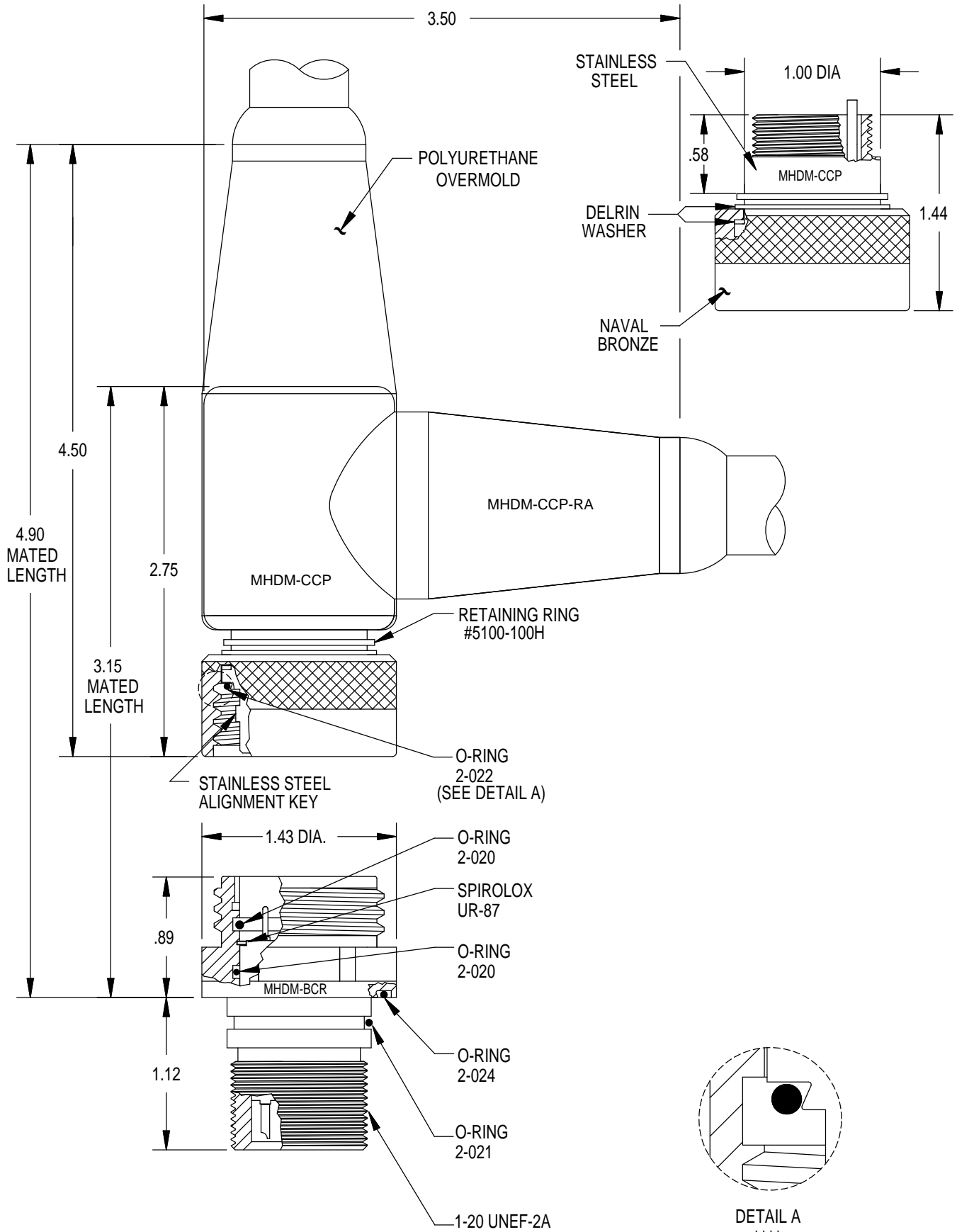

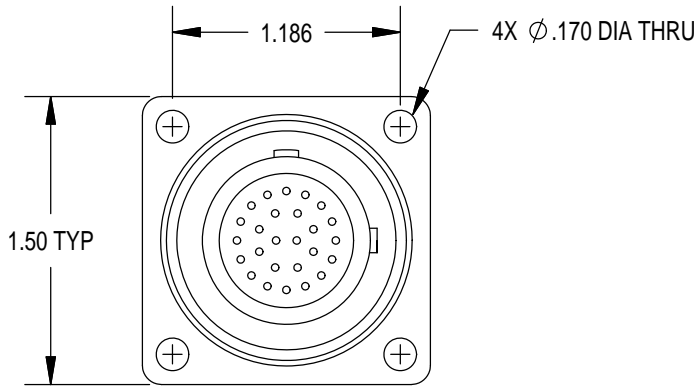

CONTACT CONFIGURATION (BCR FACE VIEW)

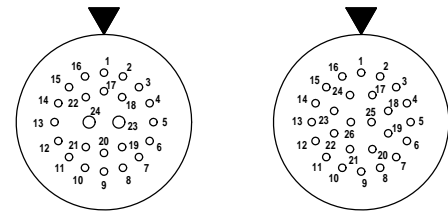

2#20
22#22
300VDC

26#20
300VDC

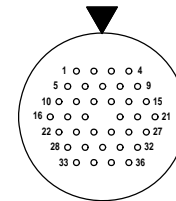

36#22
300VDC

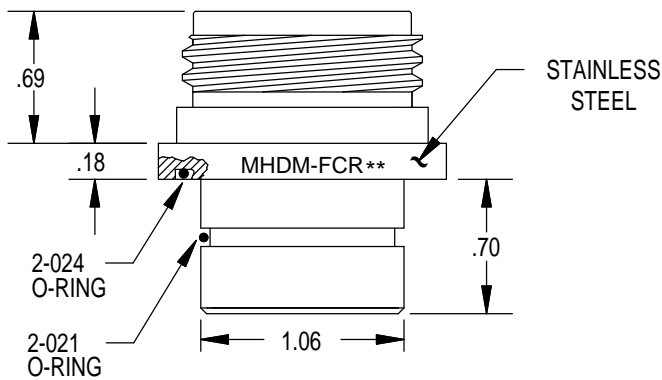

FCR MOUNTING INSTRUCTIONS

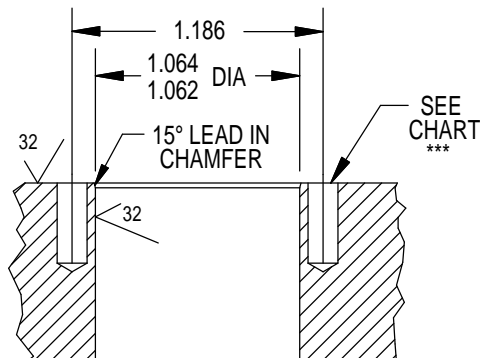

BCR MOUNTING INSTRUCTIONS

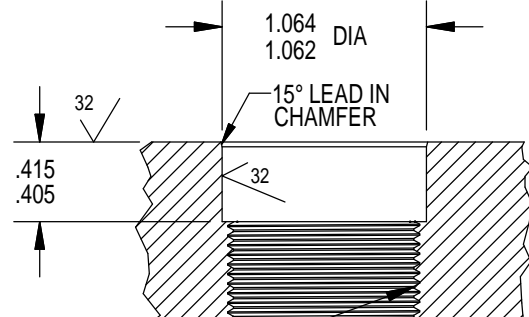

1-20 UNEF-2B

MOUNTING TORQUE FOR BCR	not to exceed 200 in lbs	MATED PRESSURE RATING (psi)	10,000
DUMMY PLUG FOR BCR	MHDM-SCP	DUMMY PLUG FOR CCP	MHDM-SCR

NOTE: CCP is not terminated to cable unless specified.

* Please specify number of contacts.

** Internal assembly is the same as the MHDM-BCR (facing page).

*** Blind tapped hole not to penetrate bulkhead, minimum full thread depth 2 times bolt diameter.

**** O-Ring installation tool available - Contact factory for further details.

MHDO

MINIATURE HIGH DENSITY SERIES

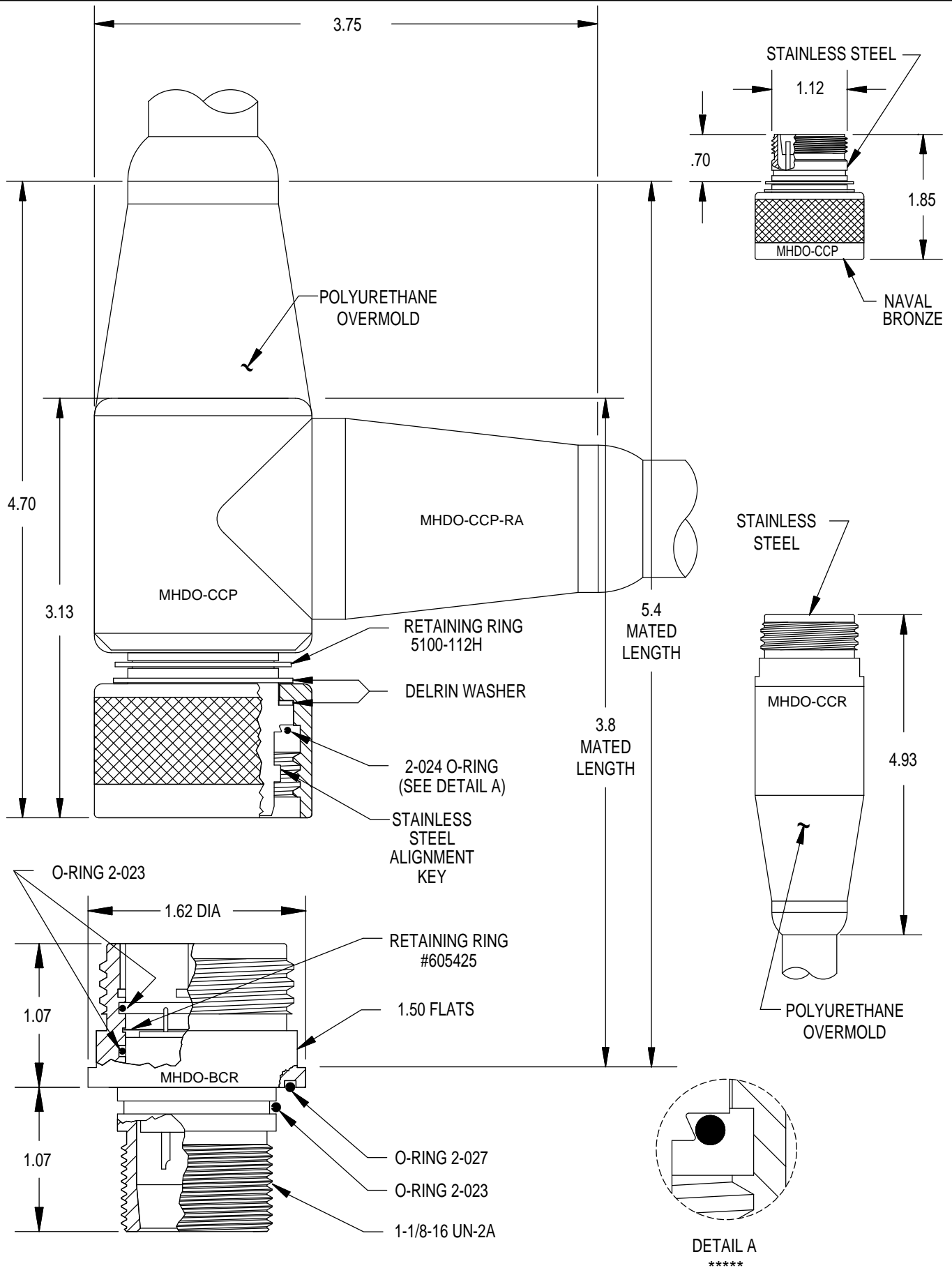

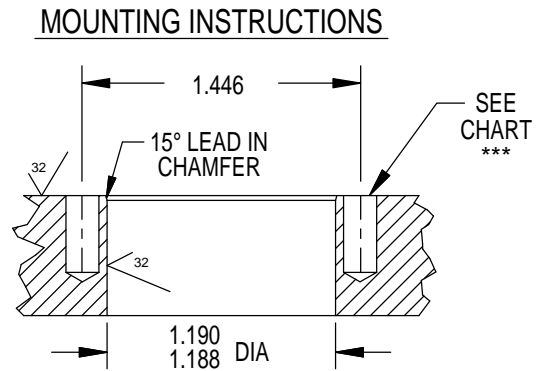
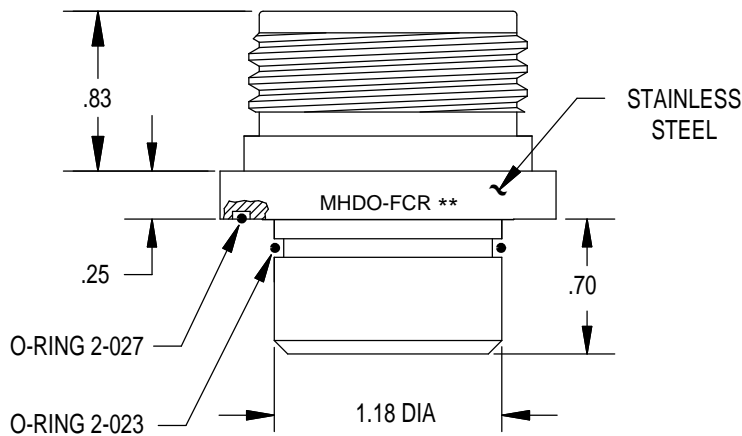
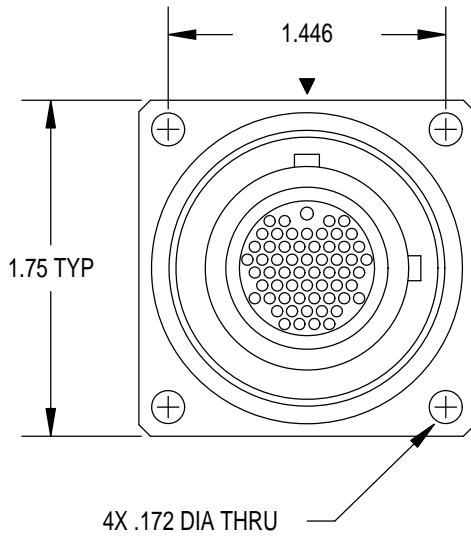

MOUNTING TORQUE FOR MHDO-BCR	not to exceed 200 in lbs	MATED PRESSURE RATING (psi)	10,000
DUMMY PLUG FOR MHDO-BCR/FCR/CCR	MHDO-SCP	DUMMY PLUG FOR MHDO-CCP	MHDO-SCR

NOTE: CCP and CCR are not terminated to cable unless specified.

* Please specify number of contacts.

** Internal assembly same as MHDO-BCR (facing page).

*** Blind tapped hole not to penetrate bulkhead, minimum full thread depth 2 times bolt diameter.

**** Oil filled version available. See section 86.

***** O-Ring installation tool available - Contact factory for further details.

CONTACT
CONFIGURATION
(BCR FACE VIEW)

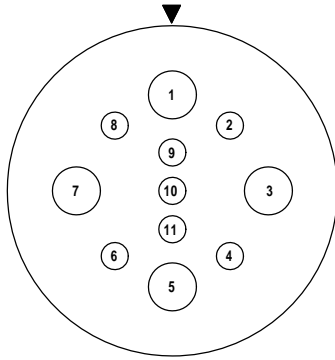

7#22
4#10
600VDC

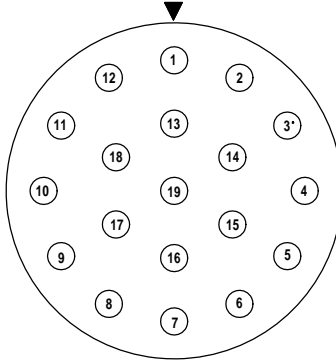

19#16
600VDC

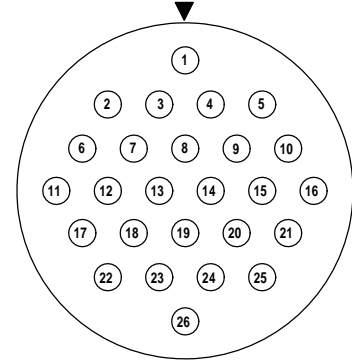

26#20
450VDC

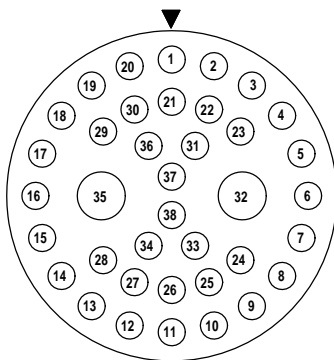

2#10
36#22
300VDC

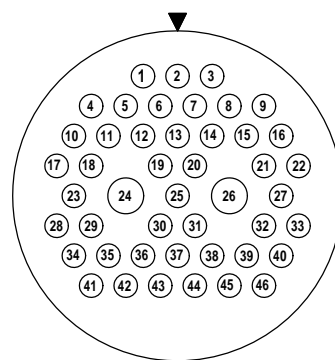

44#22
2#16
300VDC

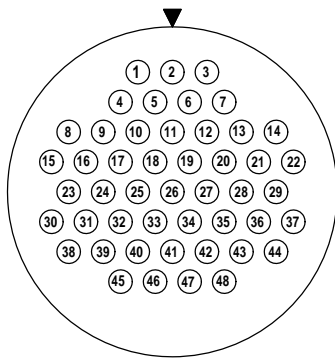

48#22
300VDC

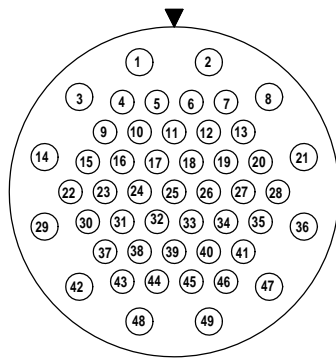

12#20
37#22
300VDC

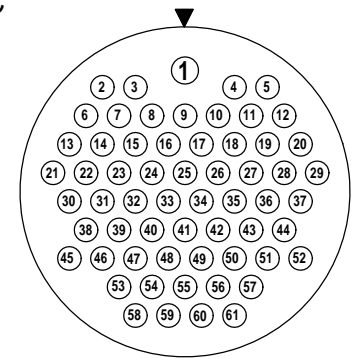

1#20
60#22
300VDC

THIS PAGE INTENTIONALLY LEFT BLANK

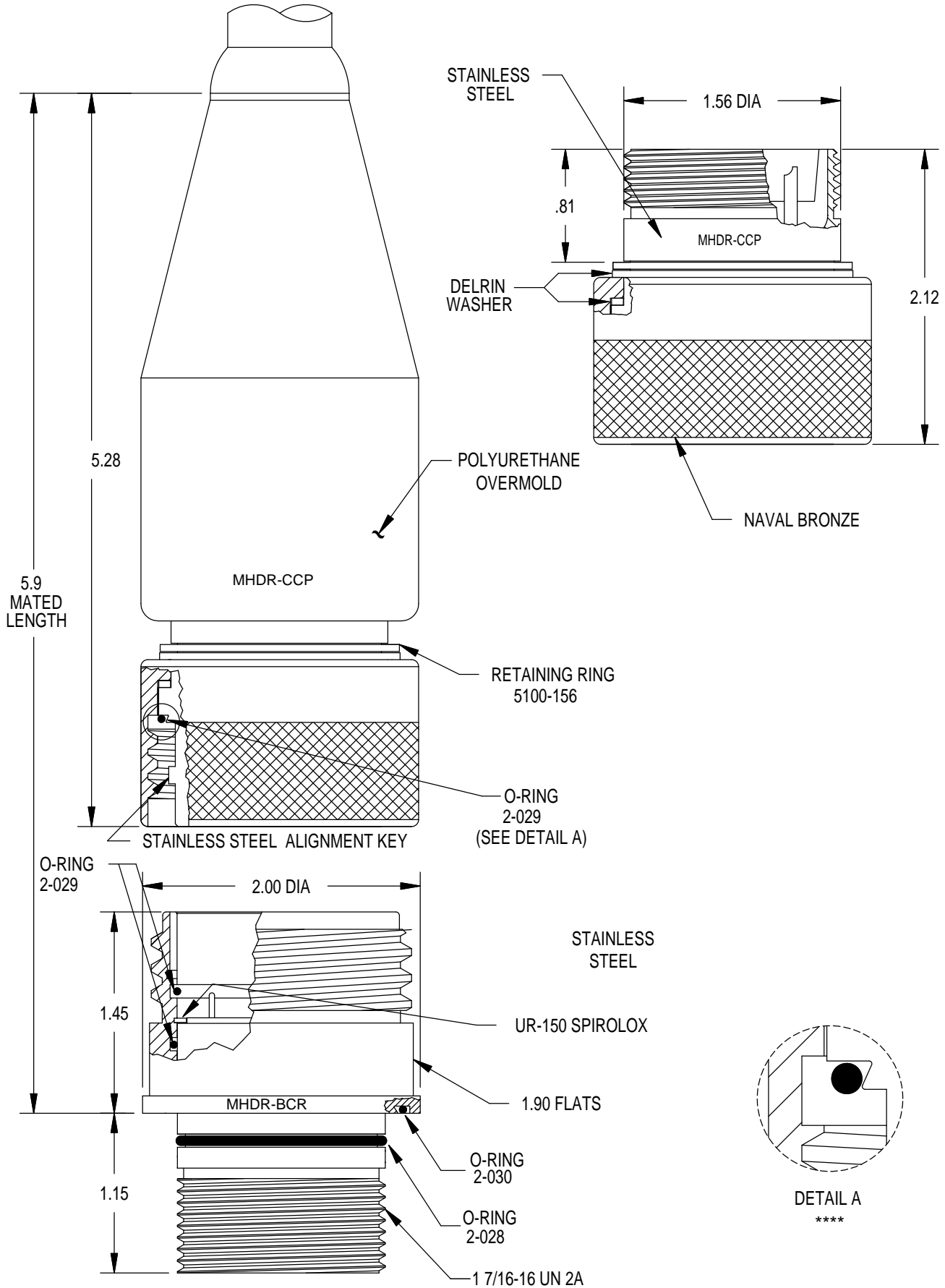

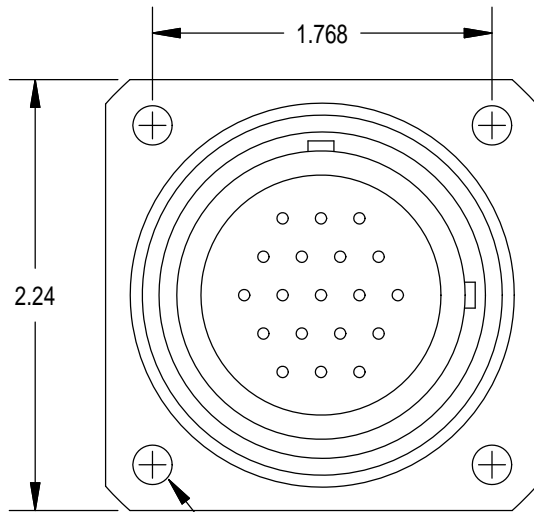

4X .205 DIA THRU

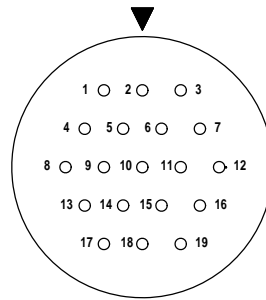

19#20

600VDC

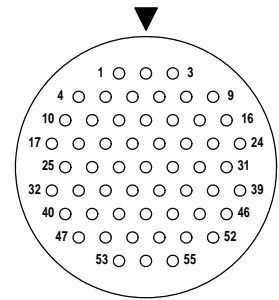

55#20

600VDC

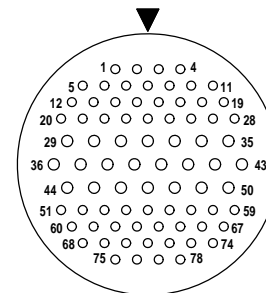

22#20

56#22
600VDC

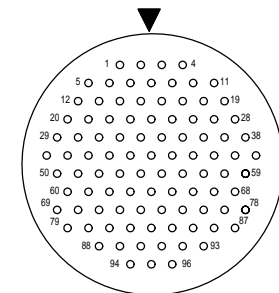

96#20

600VDC

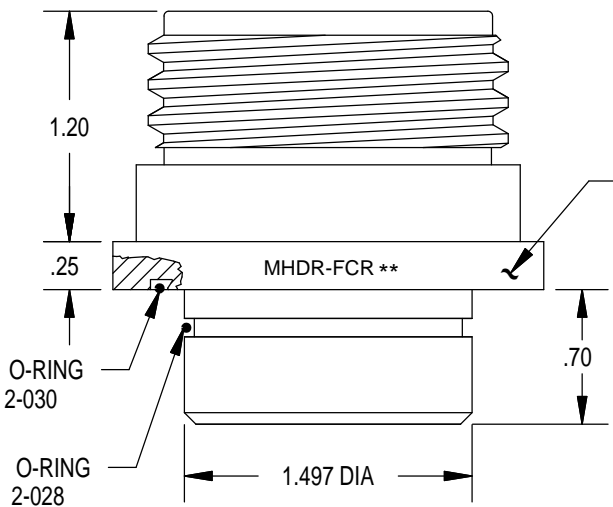

STAINLESS STEEL

MHDR-FCR **

MOUNTING INSTRUCTIONS

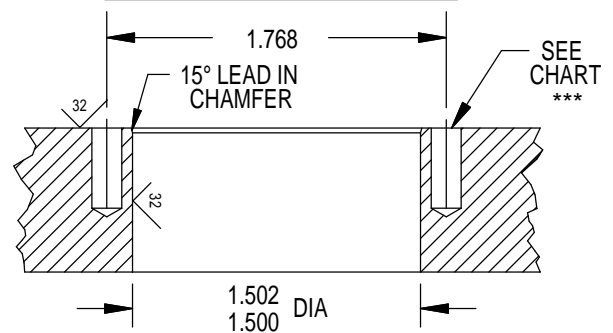

MOUNTING TORQUE FOR MHDR-BCR	not to exceed 200 in lbs	MATED PRESSURE RATING (psi)	10,000
DUMMY PLUG FOR MHDR-BCR/FCR/CCR	MHDR-SCP	DUMMY PLUG FOR MHDR-CCP	MHDR-SCR

NOTE: CCP is not terminated to cable unless specified.

* Please specify number of contacts.

** Internal assembly same as MHDR-BCR (facing page).

*** Blind tapped hole not to penetrate bulkhead, minimum full thread depth 2 times bolt diameter.

**** O-Ring installation tool available - Contact factory for further details.

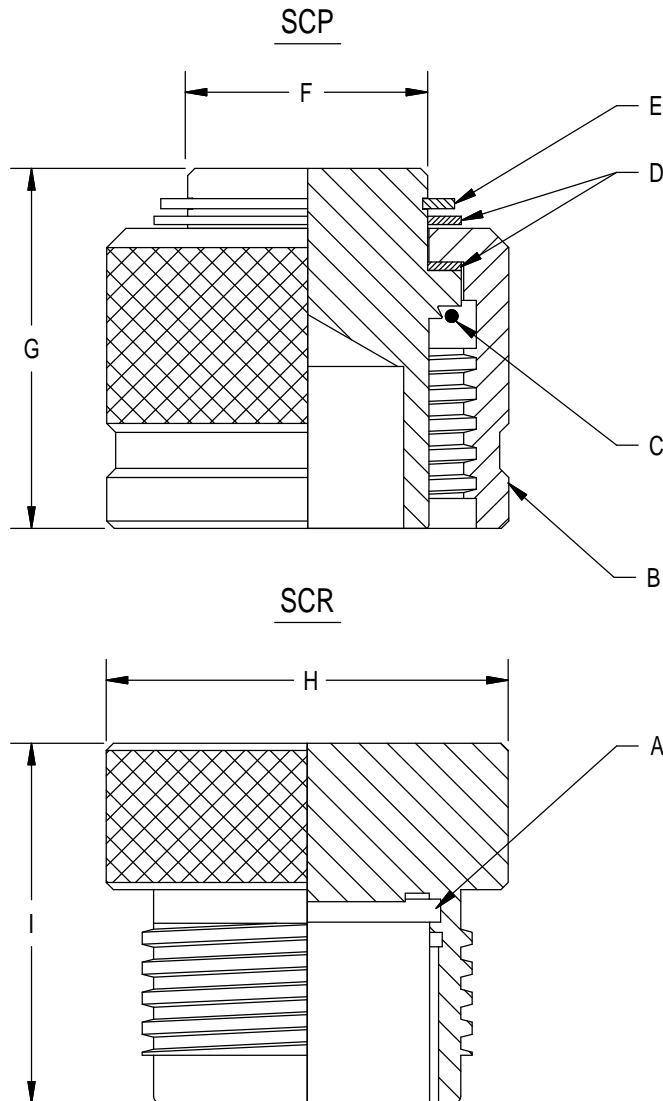

CONNECTOR SIZE	MHDG	MHDL	MHDM	MHDO	MHDR
A O-RING	2-016	2-018	2-020	2-023	2-029
B ENGAGING NUT	605165	605280	602004	605450	602261
C O-RING	2-017	R00787-039-070	2-022	2-024	2-029
D DELRIN WASHER(2X)	605101		605273	602005	605430
E RETAINING RING	5100-68	5100-75	5100-100	5100-112	5100-156
F DIA	.69	.75	1.00	1.12	1.56
G	1.05	.95	.97	1.25	1.45
H DIA	1.00	1.25	1.43	1.62	2.00
I	1.00	.90	.87	1.25	1.45
MATED PRESSURE RATING (psi)	10,000	10,000	10,000	10,000	10,000

DESCRIPTION AND MATERIAL

- 316 stainless steel passivated per QQ-P-35 Type VI with naval bronze engaging nut.
- Bulkhead connectors available as a threaded or flanged version with a removable glass reinforced epoxy insert. (Except for MHDG Series and CCP's)
- Up to 61 contacts.
- Up to 600 VDC.
- 5,000 PSI in mated condition.
- Bulkhead connector design open face pressure rated to 5,000 psi.
- Contacts are gold plated per MIL-G-45204.

USES

- For use with oil filled tubes.
- Signal telemetry.
- Hazardous environment.

GUIDELINES

- Mounting torque should not exceed 150 in/lbs. for this series.
- All mounting surfaces require a 32 finish.
- Align indexes.
- Keep o-ring grooves clean.
- Avoid o-ring cuts and nicks.
- Lubricate o-rings with Dow Corning #111 Valve Lubricant or equivalent.
- Replace o-rings when re-using connectors.
- Avoid contact with noxious solvents.
- Elastomers can be seriously degraded if exposed to direct sunlight or high ozone levels for extended periods of time.
- Slight leakage of oil through CCP face may occur.

MHDG-OF

MINIATURE HIGH DENSITY SERIES - OIL FILLED

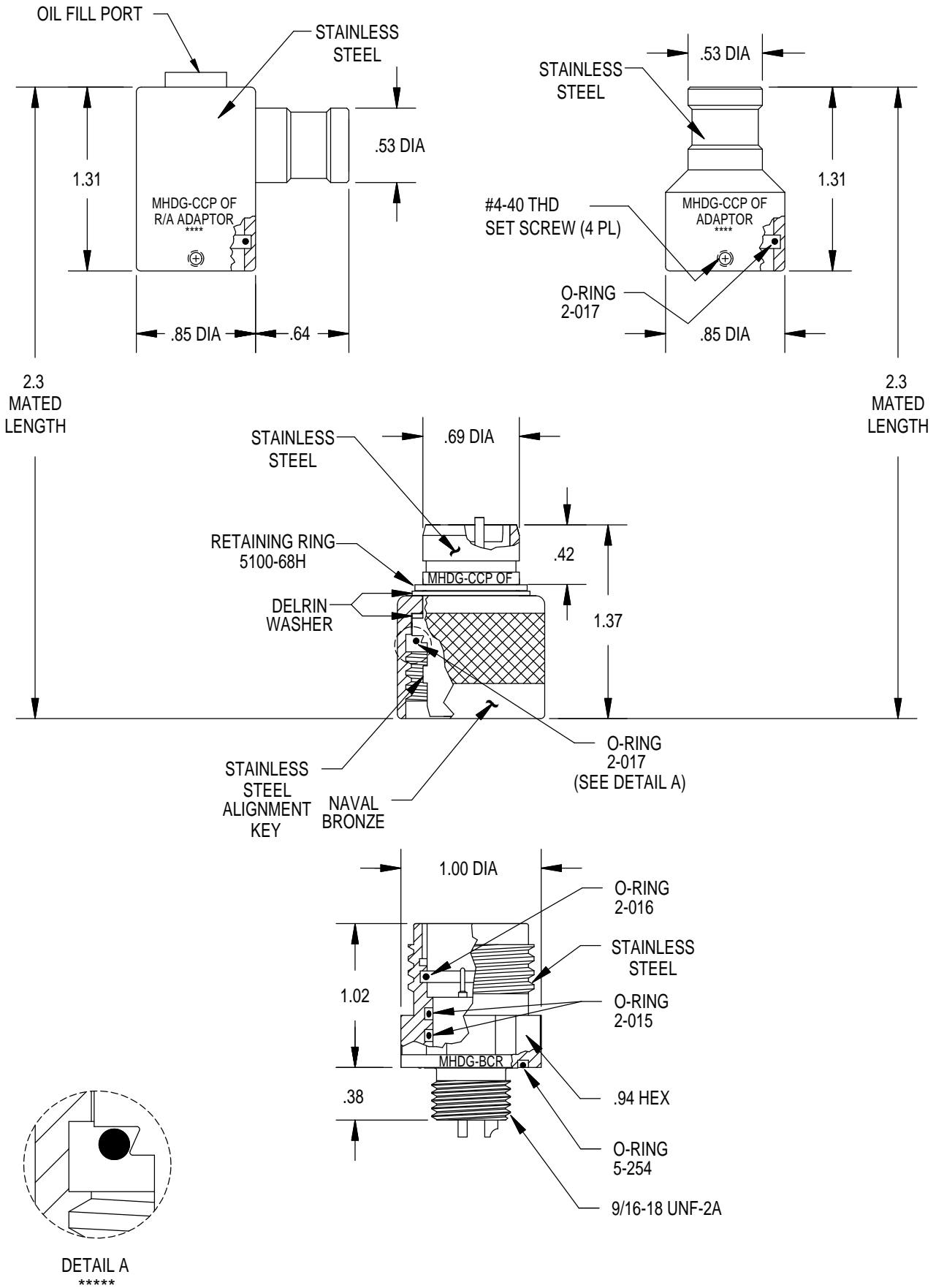

CONTACT CONFIGURATION
(BCR FACE VIEW)

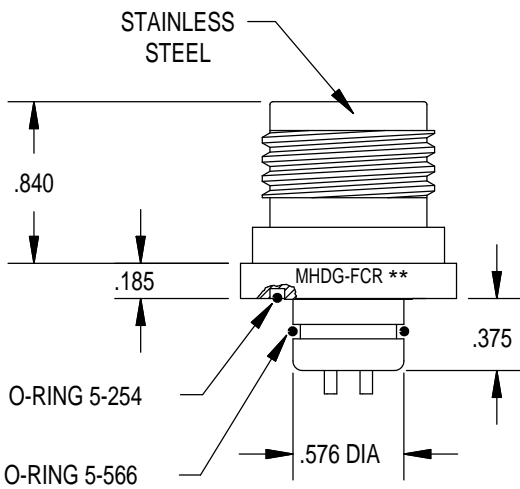
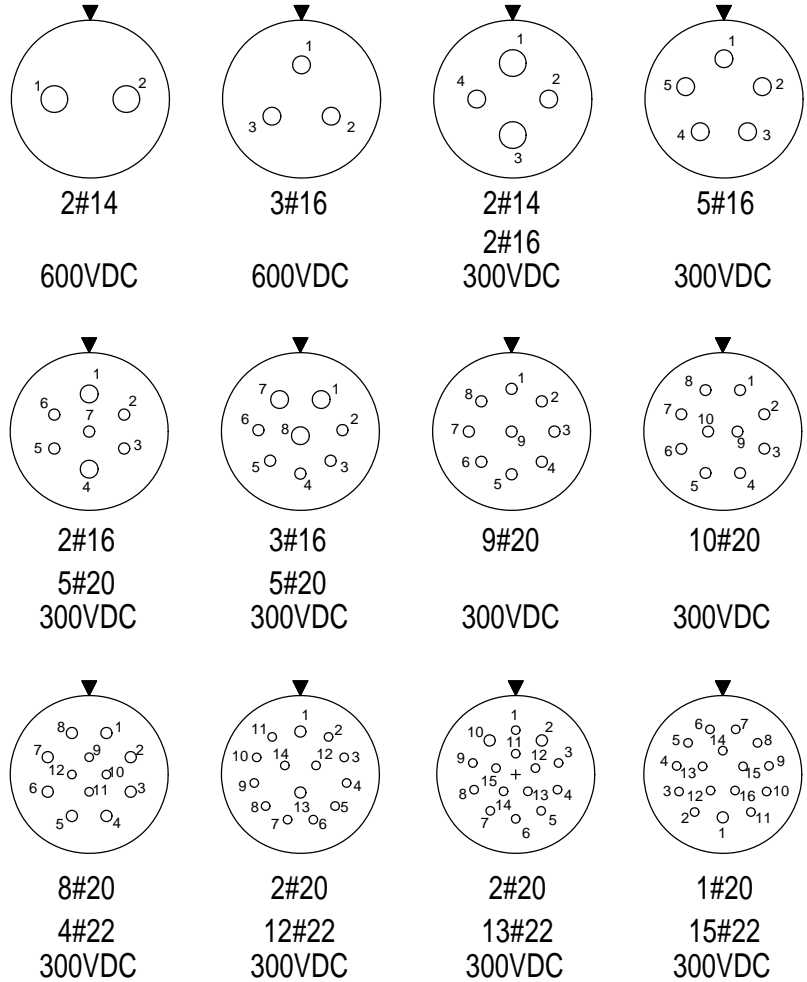
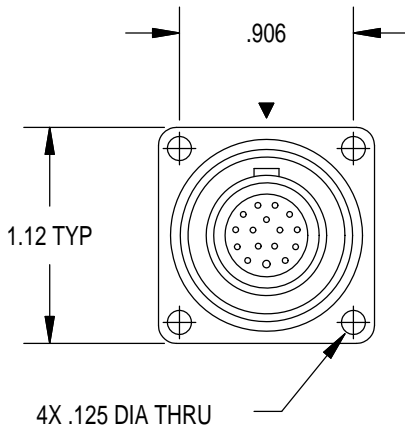

MOUNTING INSTRUCTIONS

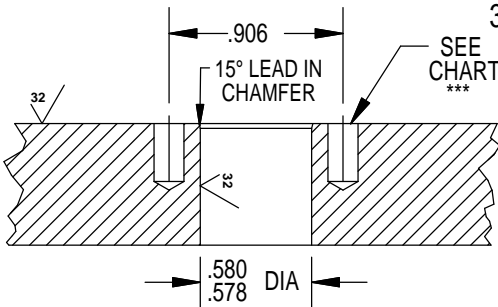

MOUNTING TORQUE FOR MHDG-BCR	not to exceed 150 in lbs	MATED PRESSURE RATING (psi)	5,000
DUMMY PLUG FOR MHDG-BCR/FCR/CCR	MHDG-SCP	DUMMY PLUG FOR MHDG-CCP	MHDG-SCR

* Please specify number of contacts.
 ** Internal assembly same as MHDG-BCR (facing page).
 *** Blind tapped hole not to penetrate bulkhead, minimum full thread depth 2 times bolt diameter.
 **** OF adaptors should only be used with CCP-OF bodies.
 ***** O-Ring installation tool available - Contact factory for further details.

MHDL-OF

MINIATURE HIGH DENSITY SERIES - OIL FILLED

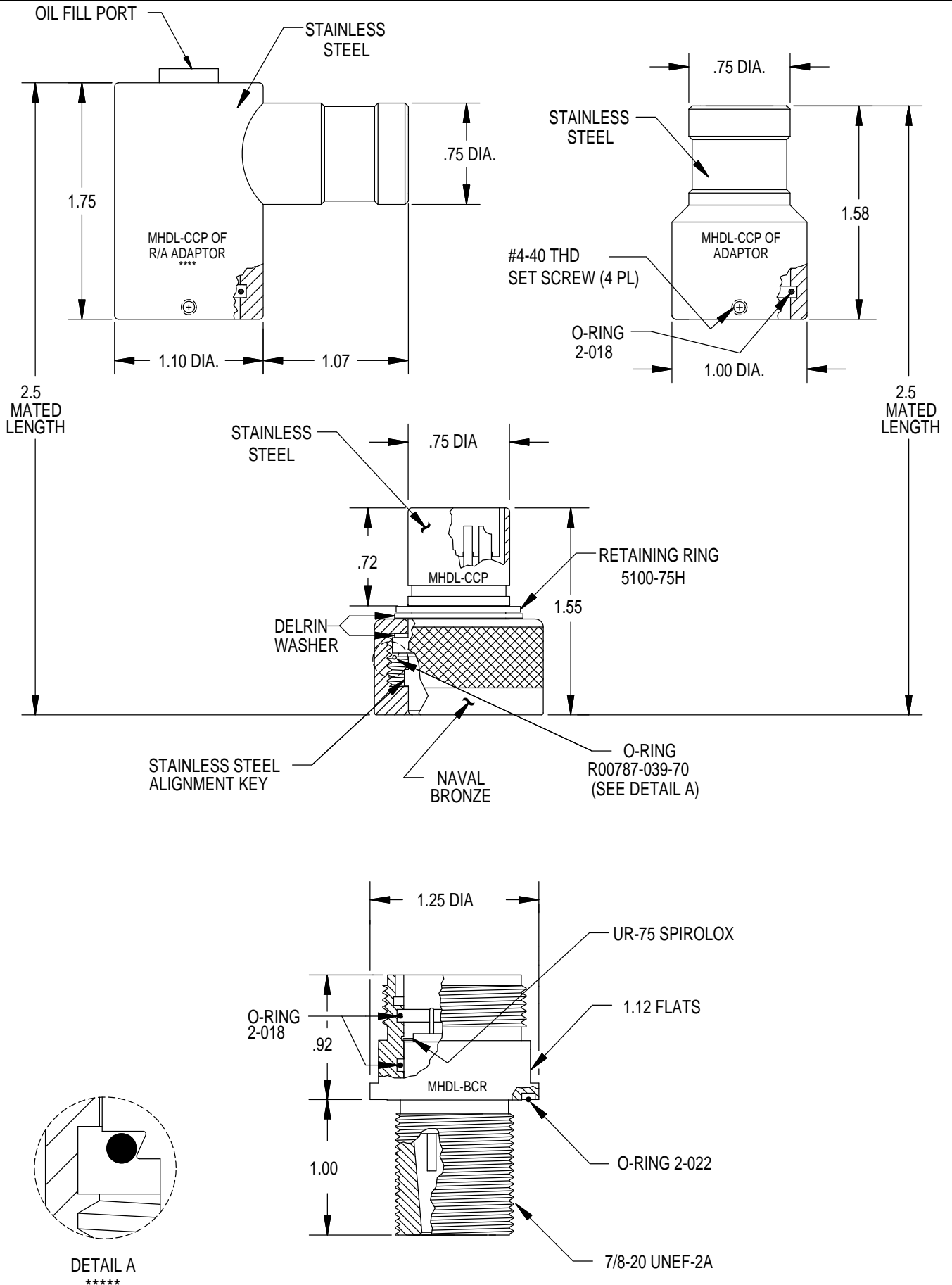

CONTACT CONFIGURATION
(BCR FACE VIEW)

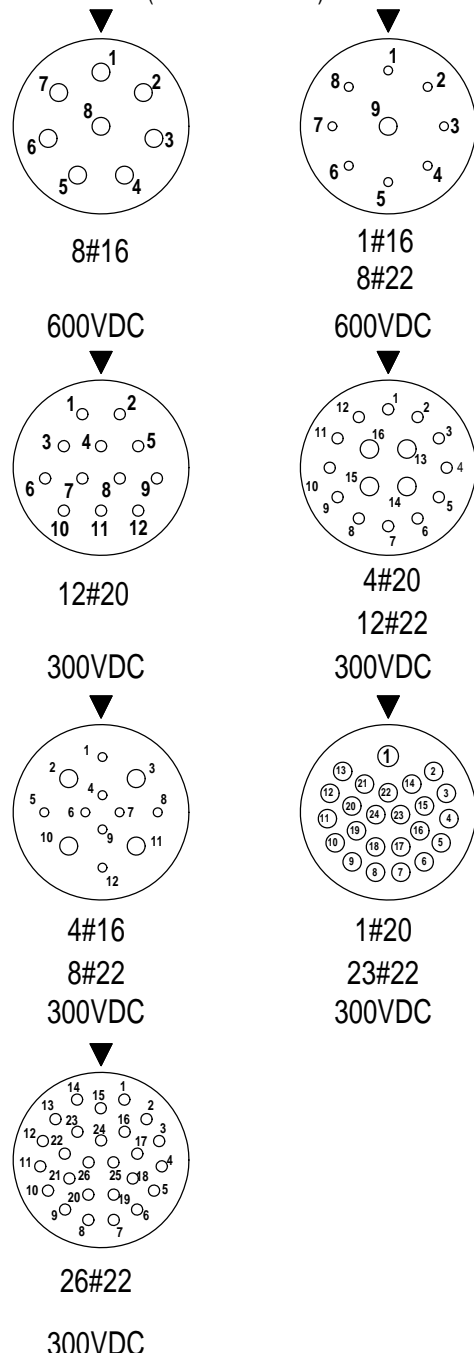
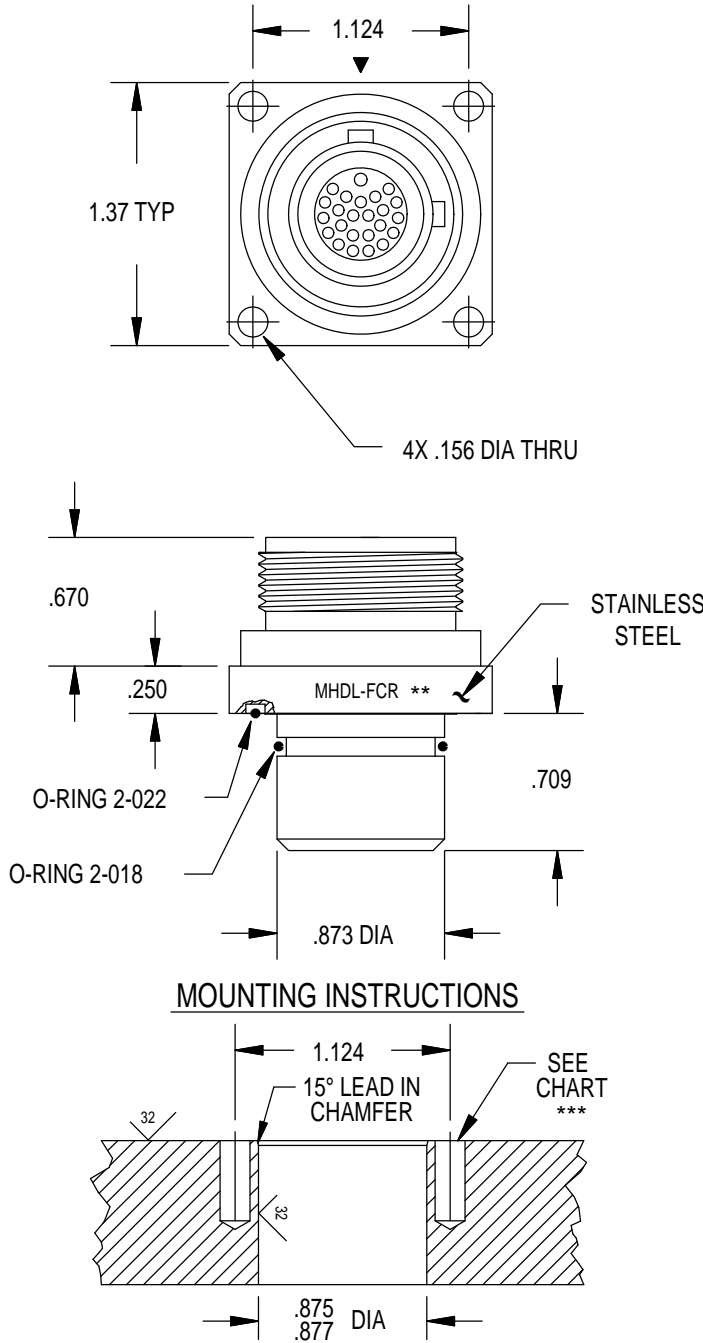

MOUNTING TORQUE FOR MHDL-BCR	not to exceed 200 in lbs	MATED PRESSURE RATING (psi)	5,000
DUMMY PLUG FOR MHDL-BCR/FCR/CCR	MHDL-SCP	DUMMY PLUG FOR MHDL-CCP	MHDL-SCR

* Please specify number of contacts.
 ** Internal assembly same as MHDL-BCR (facing page).
 *** Blind tapped hole not to penetrate bulkhead, minimum full thread depth 2 times bolt diameter.
 **** O-Ring installation tool available - Contact factory for further details.

MHDO-OF

MINIATURE HIGH DENSITY SERIES - OIL FILLED

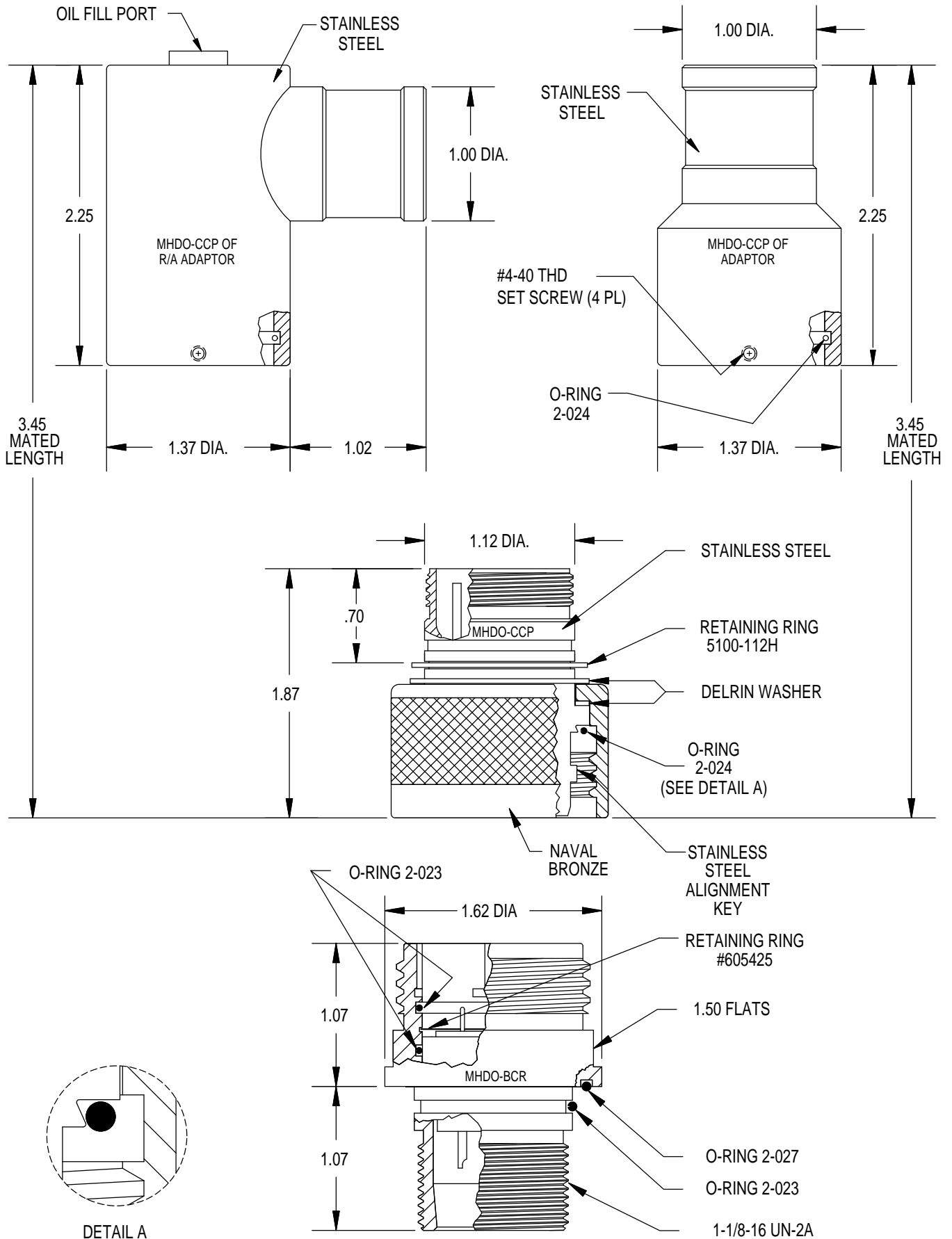

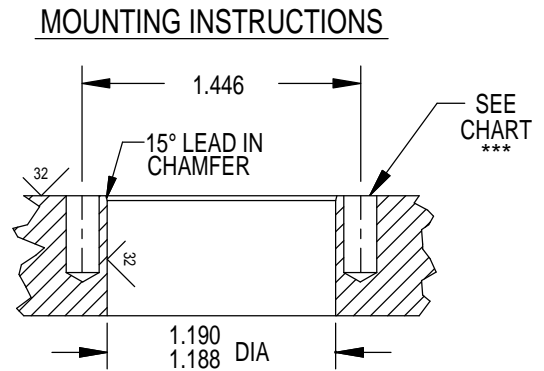
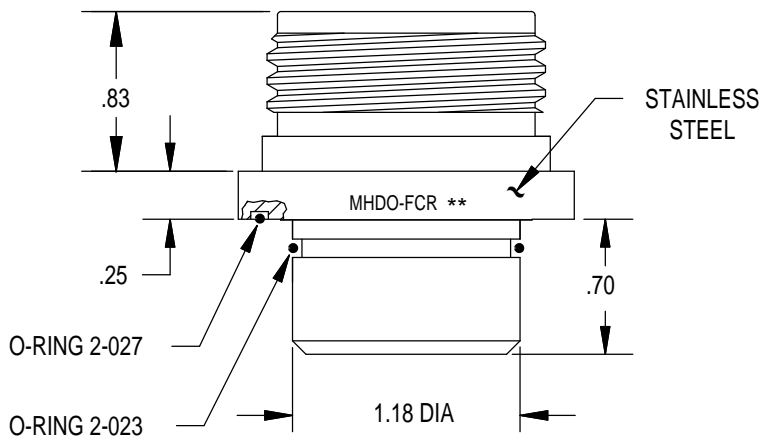
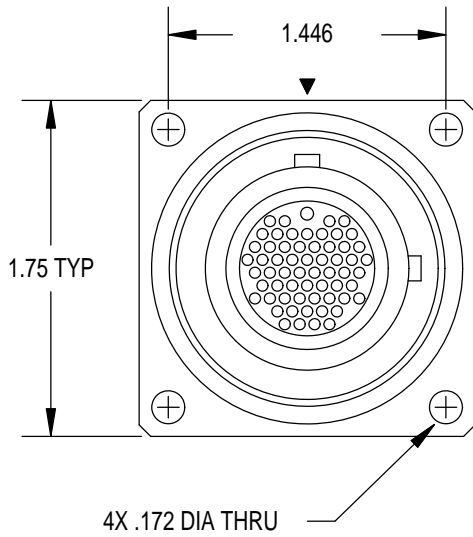

MOUNTING TORQUE FOR MHDO-BCR	not to exceed 200 in lbs	MATED PRESSURE RATING (psi)	5,000
DUMMY PLUG FOR MHDO-BCR/FCR/CCR	MHDO-SCP	DUMMY PLUG FOR MHDO-CCP	MHDO-SCR
<p>* Please specify number of contacts. ** Internal assembly same as MHDO-BCR (facing page). *** Blind tapped hole not to penetrate bulkhead, minimum full thread depth 2 times bolt diameter. **** O-Ring installation tool available - Contact factory for further information.</p>			

CONTACT
CONFIGURATION
(BCR FACE VIEW)

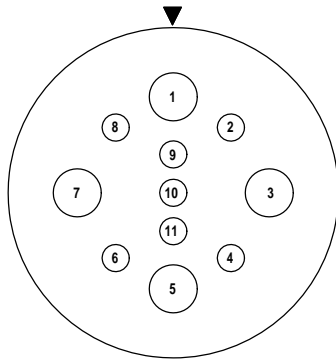

7#22
4#10
600VDC

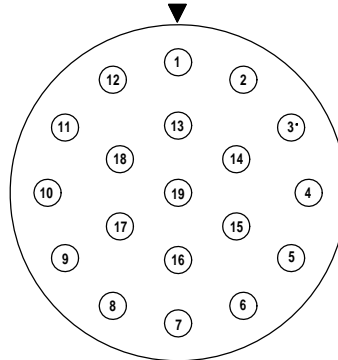

19#16
600VDC

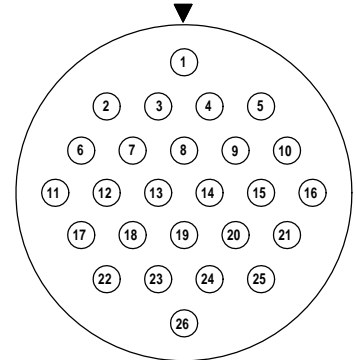

26#20
450VDC

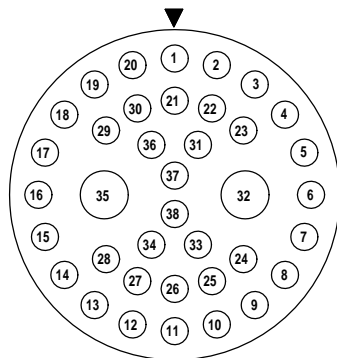

2#10
36#22
300VDC

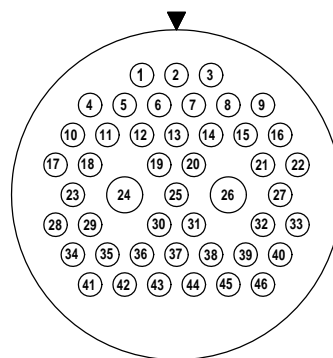

44#22
2#16
300VDC

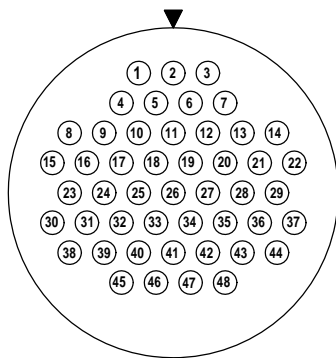

48#22
300VDC

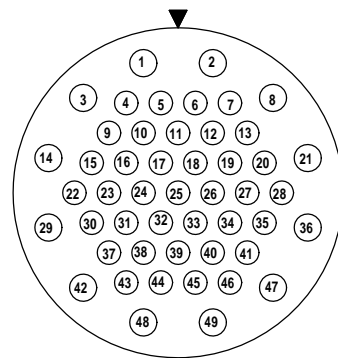

12#20
37#22
300VDC

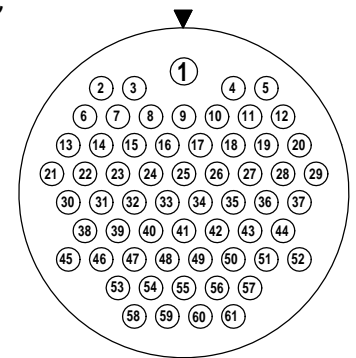

1#20
60#22
300VDC

DESCRIPTION AND MATERIAL	<ul style="list-style-type: none">• Metal to metal key for position alignment.• 316 stainless steel passivated per QQ-P-35 Type VI with naval bronze engaging nut.• Special alloys are available upon request (contact factory).• 8 contacts (#22) for 4 twisted pairs.• Contacts are gold plated per MIL-G-45204.• Working voltage up to 230 VDC.• 10,000 PSI in mated condition (higher pressure rating available using special alloy metal shell; please contact factory).• NET-CCR/CCP connectors are overmolded with polyurethane.
CABLE	<ul style="list-style-type: none">• Connector's amperage and voltage is limited by the amperage and voltage ratings of the cable to which the connector is molded.• This series is molded to Teledyne Impulse qualified cable (maximum length 70 m for 1 Gbit/s transmissions). Customer specified cables can be used, but would require testing to verify data rate.
USES	<ul style="list-style-type: none">• ROV applications.• Signal telemetry.• Hazardous environment.
GUIDELINES	<ul style="list-style-type: none">• FCR is mounted by use of four equally spaced bolts around the flange surface.• FCR is used in place of the BCR when the use of a bulkhead nut and washer is impractical.• Mounting torque should not exceed 150 in lbs. for this series.• All mounting surfaces require a 32 finish.• Align indexes.• Keep o-ring grooves clean.• Avoid o-ring cuts and nicks.• Lubricate o-rings with Dow Corning #111 Valve Lubricant or equivalent.• Replace o-rings when re-using connectors.• Elastomers can be seriously degraded if exposed to direct sunlight or high ozone levels for extended periods of time.

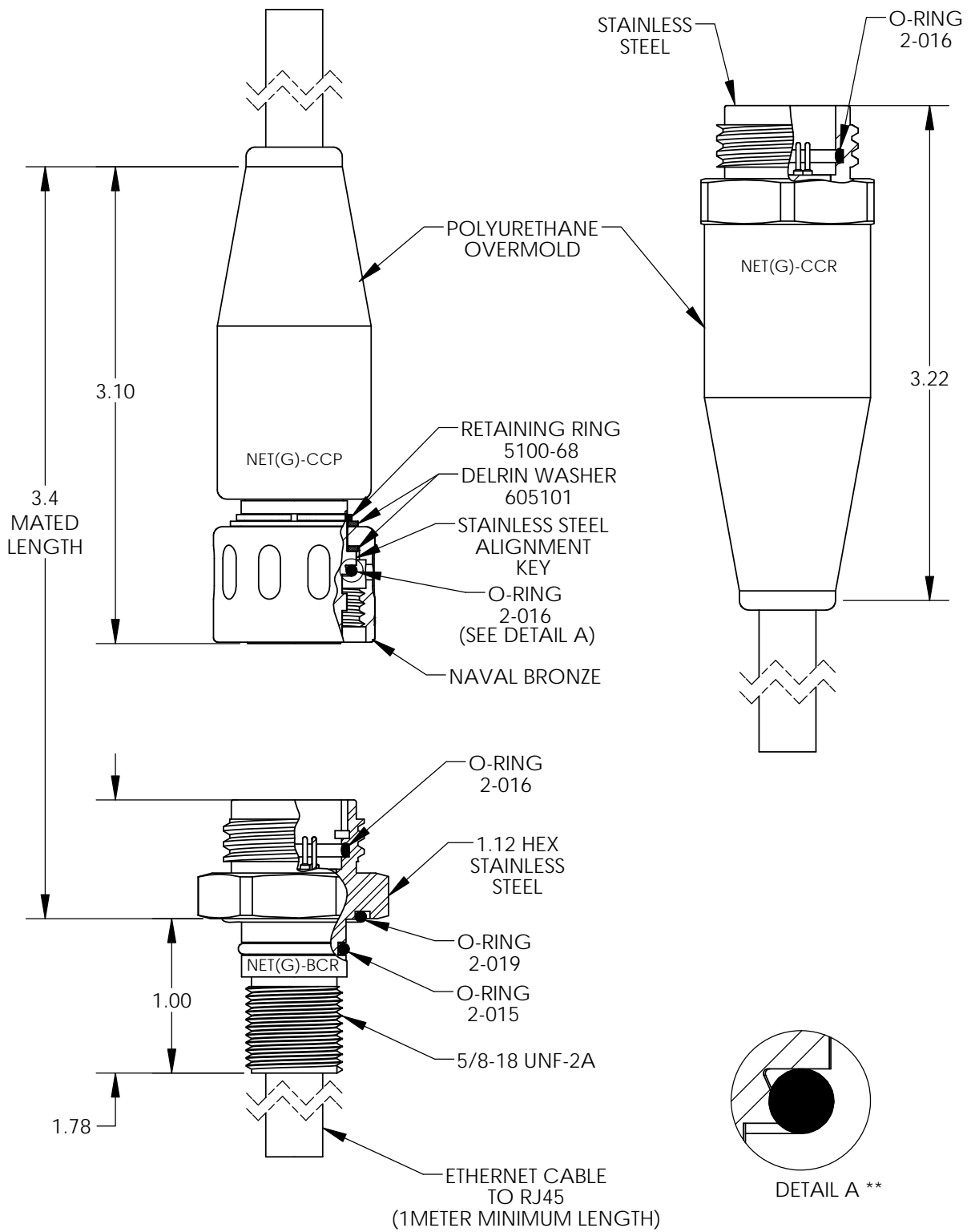

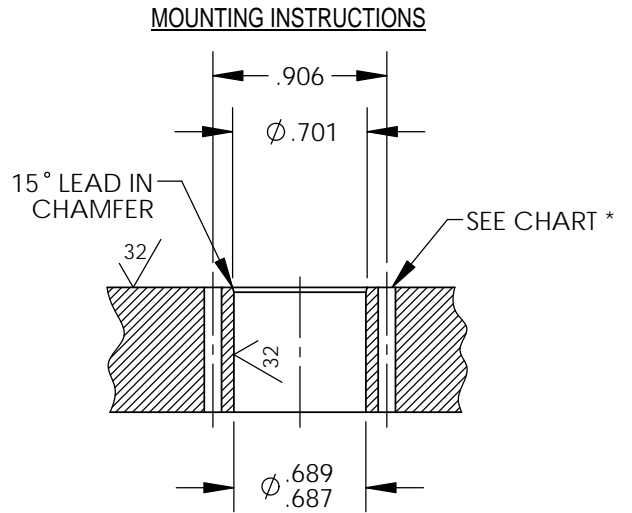
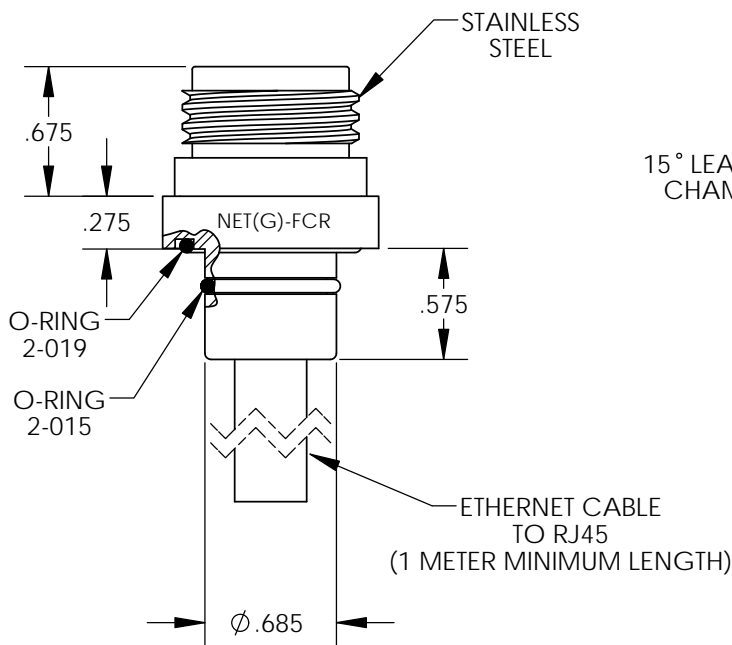
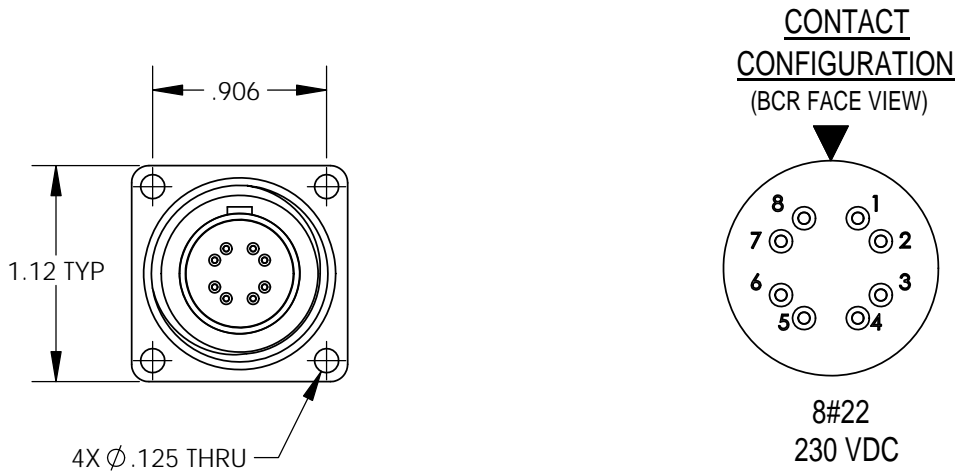

MOUNTING TORQUE FOR NET(G)-BCR	not to exceed 150 in lbs	MATED PRESSURE RATING (psi)	10,000
DUMMY PLUG FOR NET(G)-BCR/FCR/CCR	NET(G)-SCP	DUMMY PLUG FOR NET(G)-CCP	NET(G)-SCR

NOTE:

- * Blind tapped hole not to penetrate bulkhead, minimum full thread depth 2 times bolt diameter.
- ** O-Ring installation tool available - contact factory for further details.
- *** Total assembly length not to exceed 70 meters for 1 Gbit transmission.

SCP

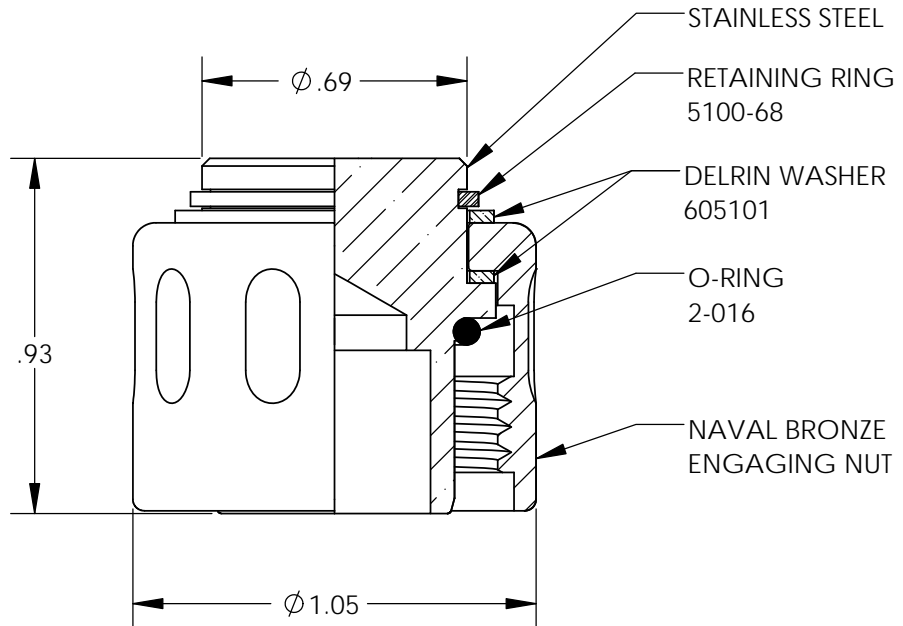

SCR

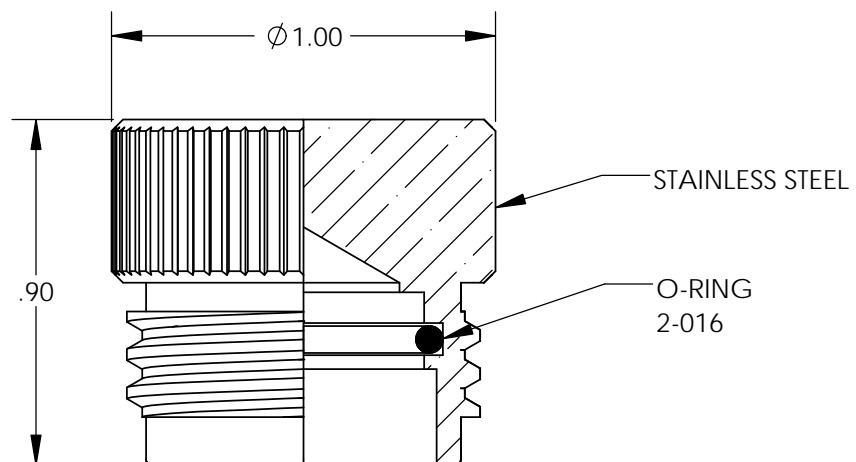

DESCRIPTION AND MATERIAL	<ul style="list-style-type: none">• Metal to metal key for positive alignment.• 316 Stainless Steel passivated per QQ-P-35 Type VI with naval bronze engaging nut.• Special alloys are available upon request (contact factory).• 10,000 PSI in mated condition.• Bulkhead connector design open face pressure rated to 5000 PSI.• Contacts gold plated per MIL-G-45204.• Engaging nuts have Acme threads for rugged applications and for quick connection.• Working voltage - 300 VDC
CABLE	<ul style="list-style-type: none">• CCP is not terminated to cable unless specified at the time of order• BCR has teflon leads, Type E per MIL 16878/4
USES	<ul style="list-style-type: none">• Light and Heavy Duty applications.• Hazardous environment.• Power Transmission.• Signal Telemetry.• ROV applications.
GUIDELINES	<ul style="list-style-type: none">• All mounting and sealing surfaces require a 32 finish.• Lubricate mating surfaces with 3M Silicone Spray or equivalent, DO NOT grease! Connectors must be lubricated on a regular basis.• Lubricate o-rings with Dow Corning #111 Valve Lubricant or equivalent.• Use Dust Caps and keep connectors clean to prevent damage in storage and service.• Keep o-ring grooves clean and avoid cuts, nicks and tears on rubber surfaces.• Elastomers can be seriously degraded if exposed to direct sunlight or high ozone levels for extended periods of time.• Clean plugs and receptacles with soap and fresh water. Rinse out with alcohol, allowing connector to air dry.• Replace o-rings when re-using connectors.

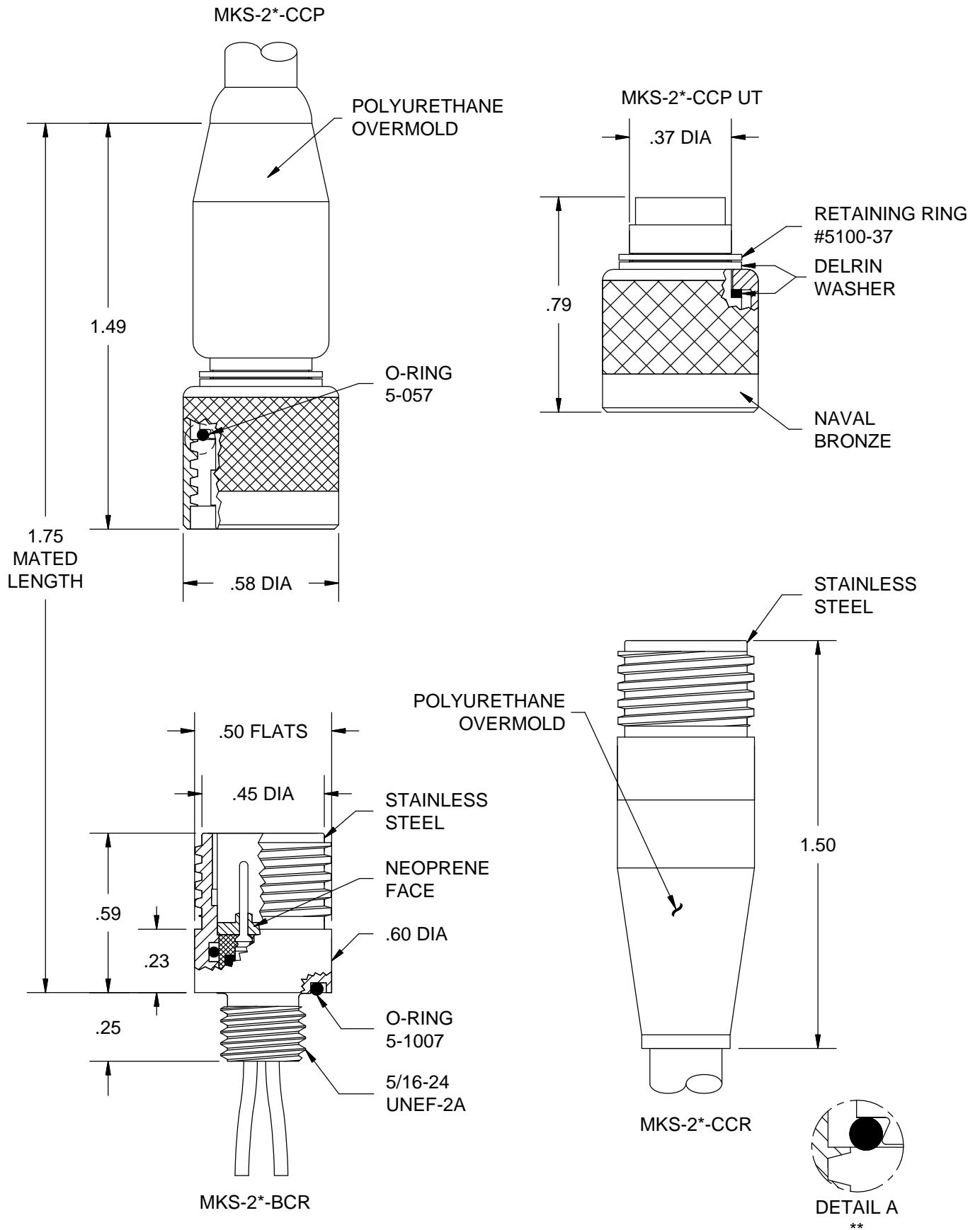

**CONTACT CONFIGURATION
(BCR FACE VIEW)**

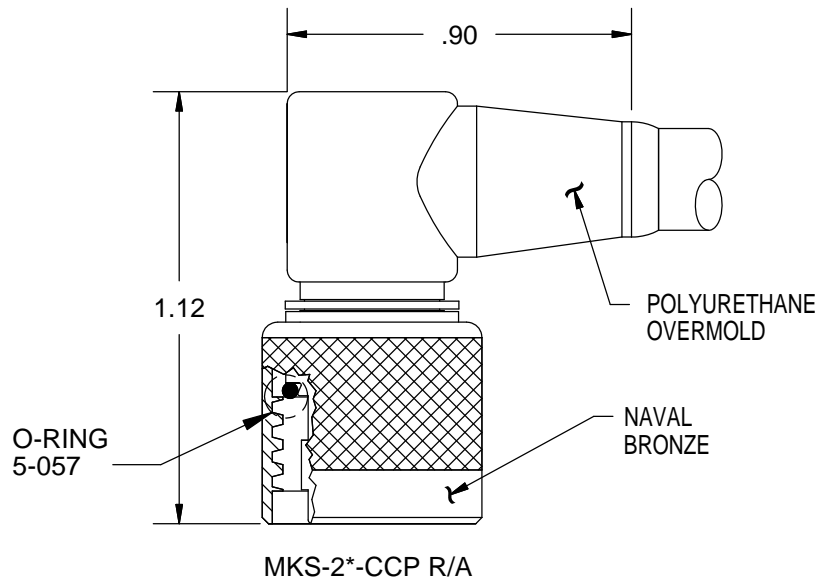
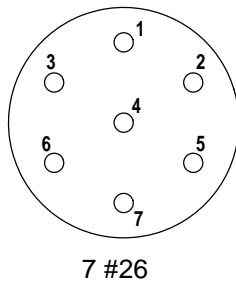
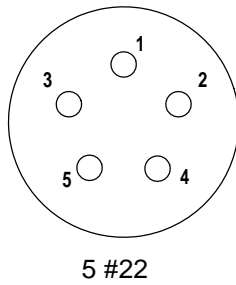

MOUNTING TORQUE FOR BCR	not to exceed 50 in-lbs	MATED PRESSURE RATING (psi)	10,000
See page 95 80 for SCP/SCR information			
<p>NOTE: CCP is not terminated to cable unless specified.</p> <p>* Please specify number of contacts.</p> <p>** O-Ring installation tool available - Contact factory for further details.</p>			

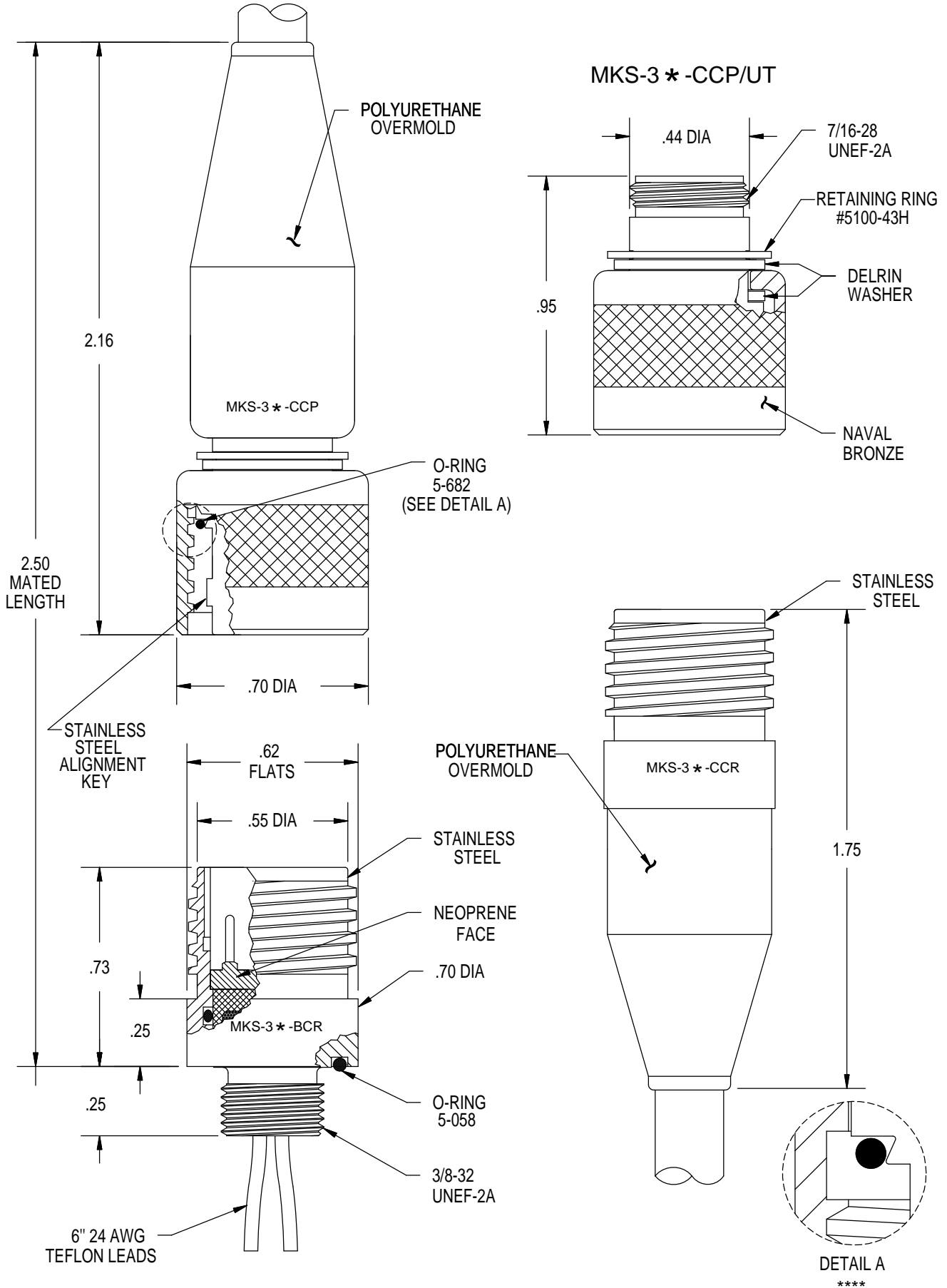

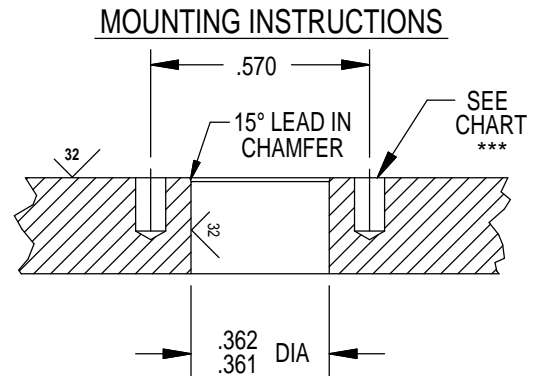
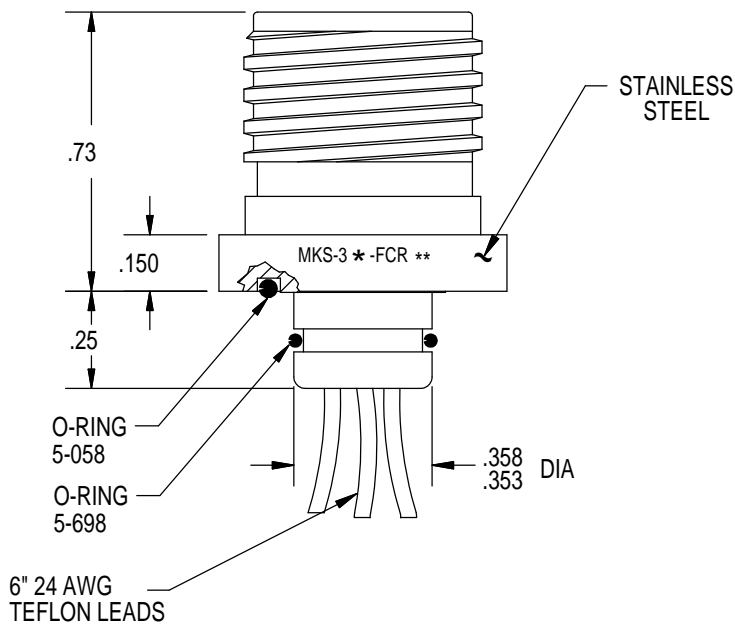
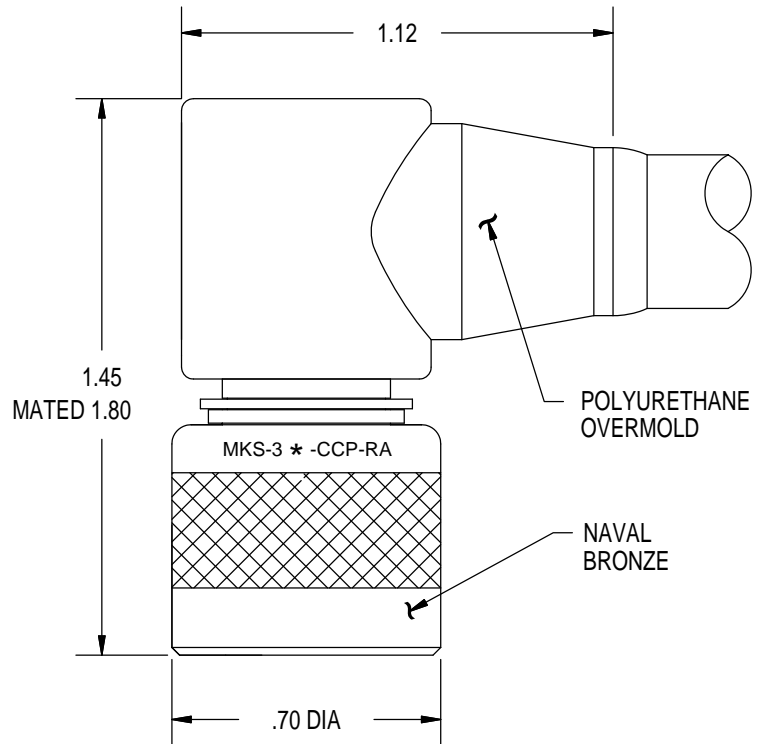
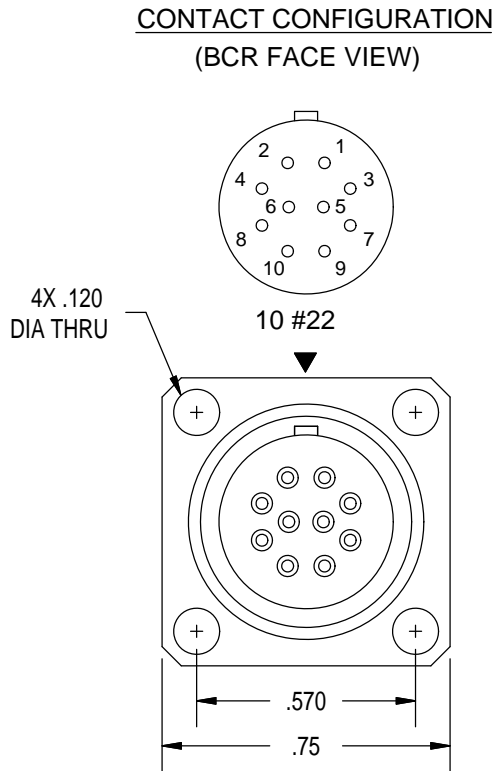

MOUNTING TORQUE FOR BCR	not to exceed 50 in lbs	MATED PRESSURE RATING (psi)	10,000
----------------------------	----------------------------	-----------------------------	--------

See pg. 9580 for SCP/SCR information.

NOTE: CCP is not terminated to cable unless specified.

* Please specify number of contacts.

** Internal assembly same as MKS-3 * -BCR (facing page).

*** Blind tapped hole not to penetrate bulkhead, minimum full thread depth 2 times bolt diameter.

**** O-Ring installation tool available - Contact factory for further details.

THIS PAGE INTENTIONALLY LEFT BLANK

DESCRIPTION AND MATERIAL	<ul style="list-style-type: none">• Wet Pluggable.• Metal to metal key for positive alignment.• 316 Stainless Steel passivated per QQ-P-35 Type VI with naval bronze engaging nut.• Special alloys are available upon request (contact factory).• 10,000 PSI in mated condition.• Bulkhead connector design open face pressure rated to 5000 PSI.• Contacts gold plated per MIL-G-45204.• Engaging nuts have Acme threads for rugged applications and for quick connection.• Working voltage for MKS-200/300/3L00/400-BCR/FCR/CCP is 300 VDC.• Working voltage for MKS-500/700/900-BCR/FCR/CCP is 600 VDC.
CABLE	<ul style="list-style-type: none">• CCP is not terminated to cable unless specified at the time of order• MKS-200/300/3L00/400-BCR/FCR has Type E leads per MIL 16878/4.• MKS-500/700/900-BCR/FCR has Type EE leads per MIL 16878/5.
USES	<ul style="list-style-type: none">• Light and Heavy Duty applications.• Hazardous environment.• Power Transmission.• Signal Telemetry.• ROV applications.
GUIDELINES	<ul style="list-style-type: none">• All mounting and sealing surfaces require a 32 finish.• Lubricate mating surfaces with 3M Silicone Lubricant or equivalent, DO NOT grease! Connectors must be lubricated on a regular basis.• Lubricate o-rings with Dow Corning #111 Valve Lubricant or equivalent.• Use Dust Caps and keep connectors clean to prevent damage in storage and service.• Keep o-ring grooves clean and avoid cuts, nicks and tears on rubber surfaces.• Elastomers can be seriously degraded if exposed to direct sunlight or high ozone levels for extended periods of time.• Clean plugs and receptacles with soap and fresh water. Rinse out with alcohol, allowing connector to air dry.• Replace o-rings when re-using connectors.

MKS(W)-2

METAL KEY RUBBER MOLDED
TITAN™ SERIES

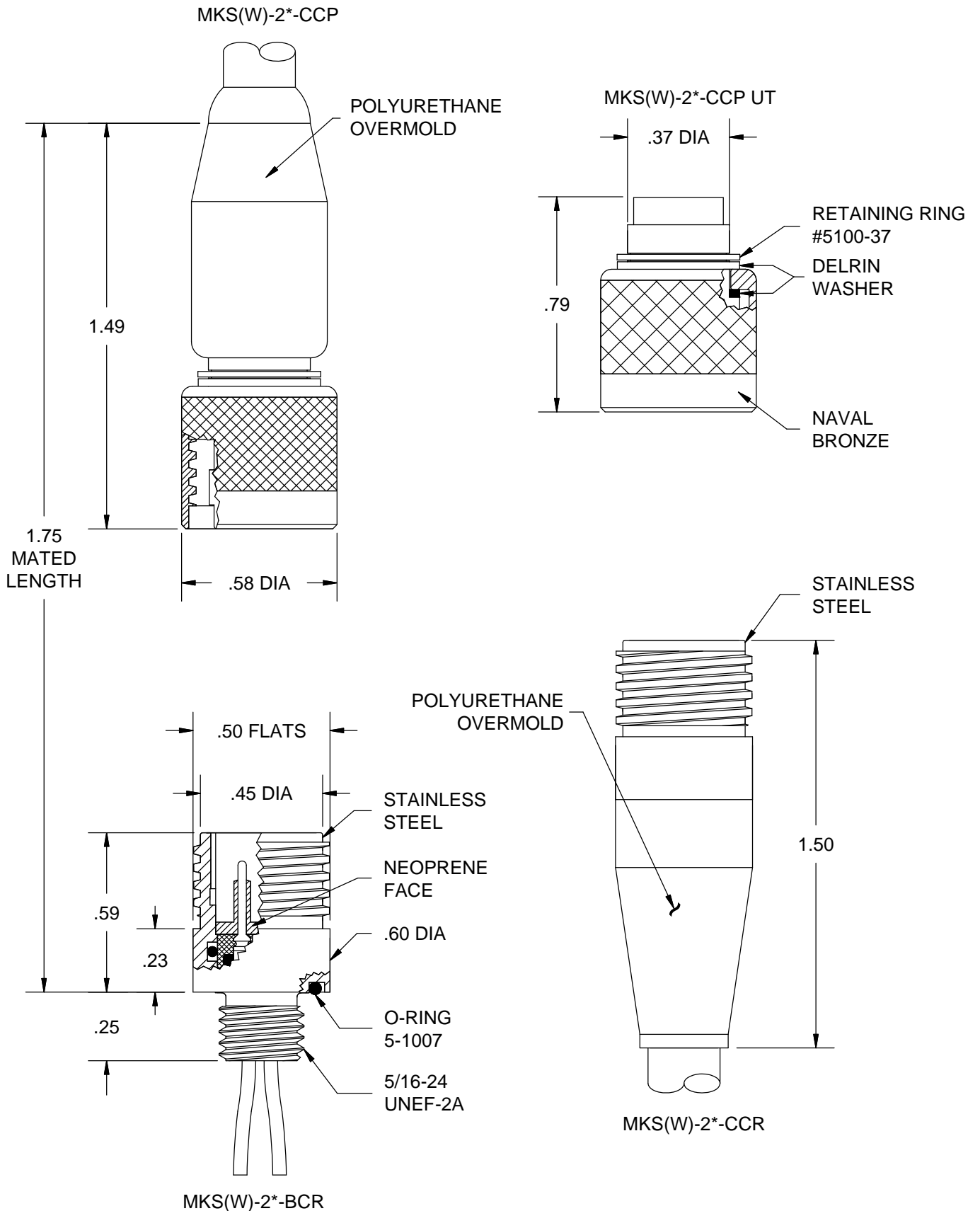

CONTACT CONFIGURATION
(BCR FACE VIEW)

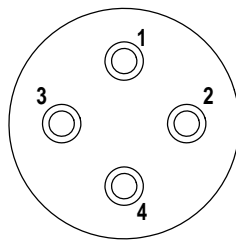

4 #22

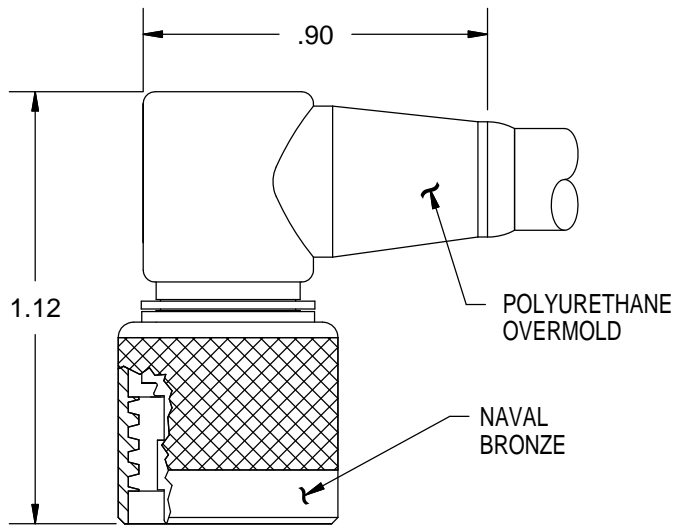

MKS(W)-2*-CCP R/A

MOUNTING TORQUE FOR BCR	not to exceed 50 in-lbs	MATED PRESSURE RATING (psi)	10,000
See page 95 80 for SCP/SCR information			
<p>NOTE: CCP is not terminated to cable unless specified.</p> <p>* Please specify number of contacts.</p> <p>** O-Ring installation tool available - Contact factory for further details.</p>			

MKS(W)-3

METAL KEY WET PLUGGABLE RUBBER MOLDED TITAN™ SERIES

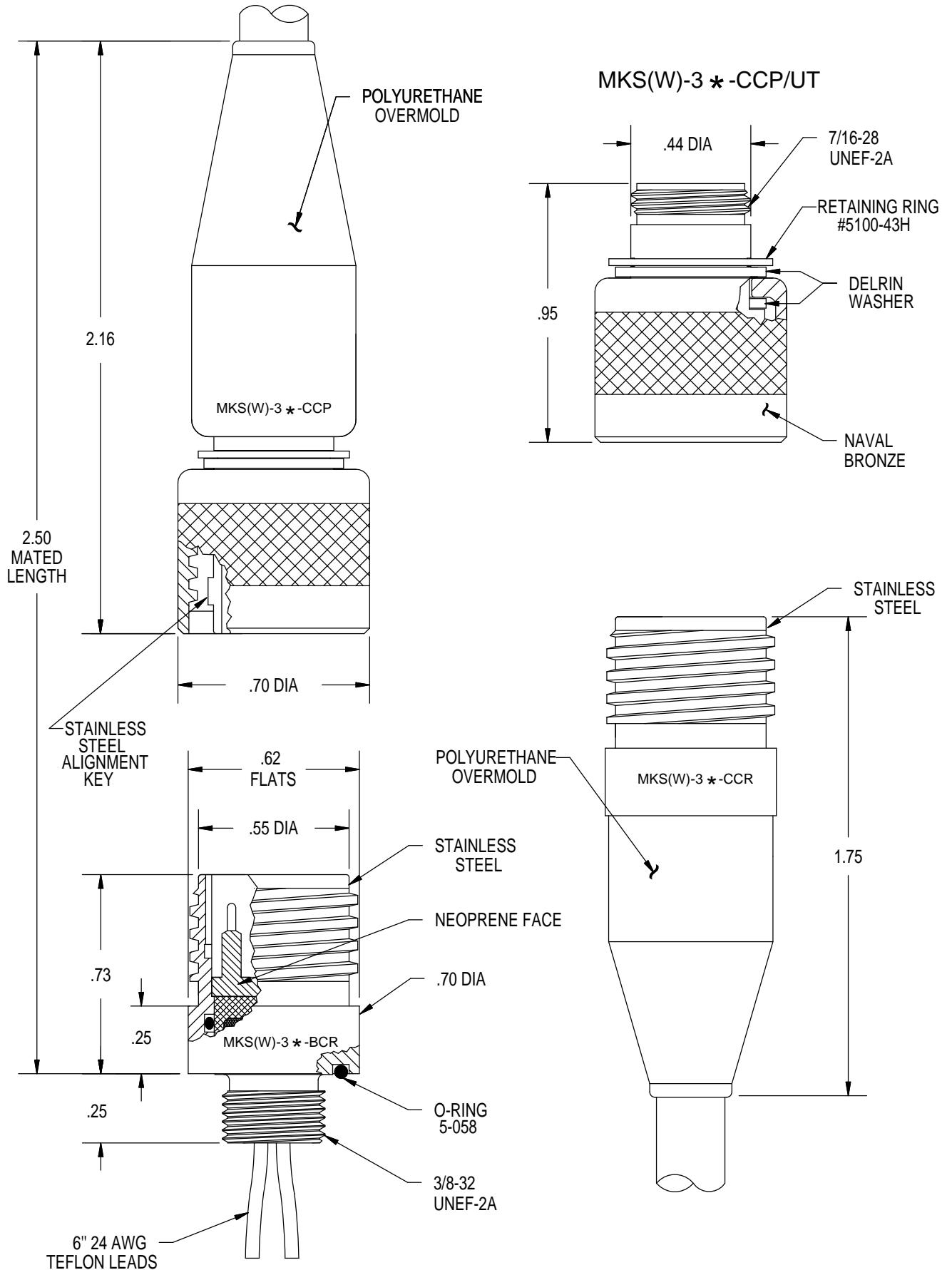

MKS(W)-3

METAL KEY WET PLUGGABLE RUBBER MOLDED TITAN™ SERIES

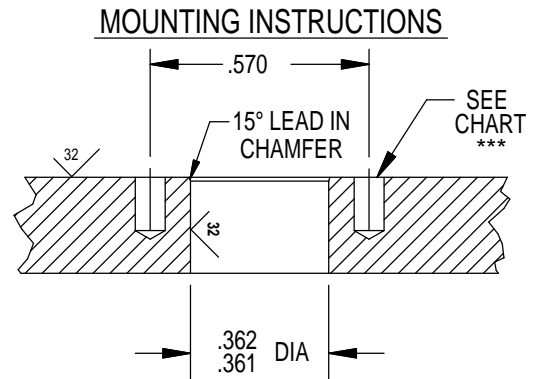
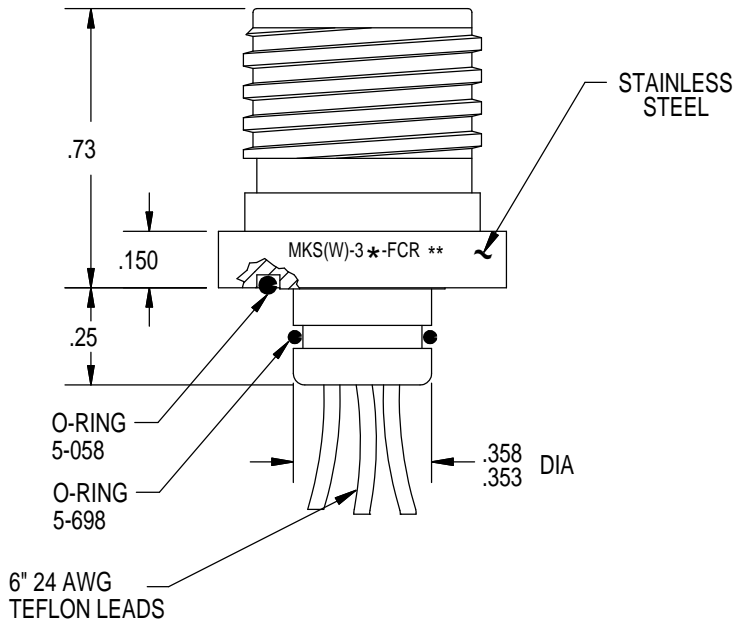
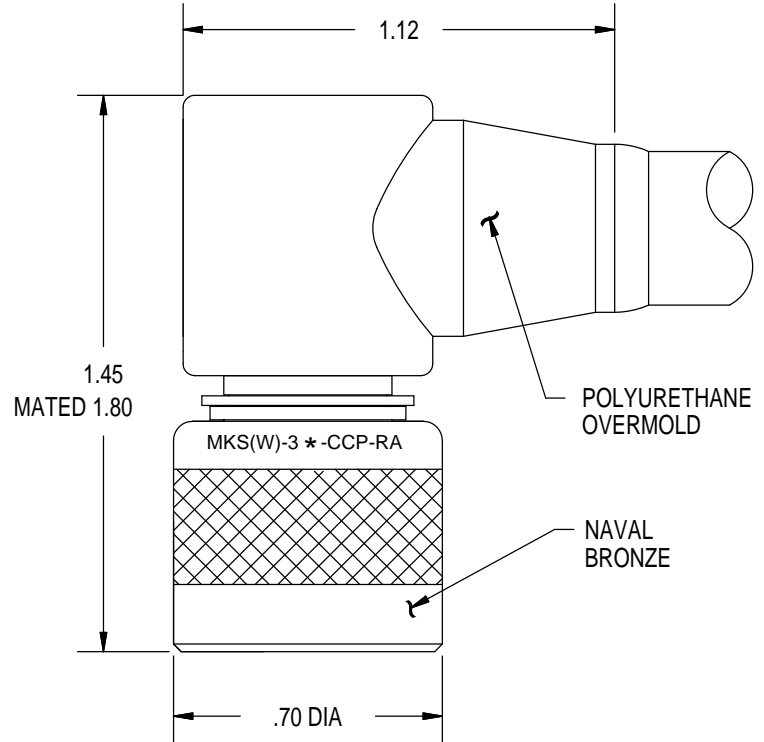
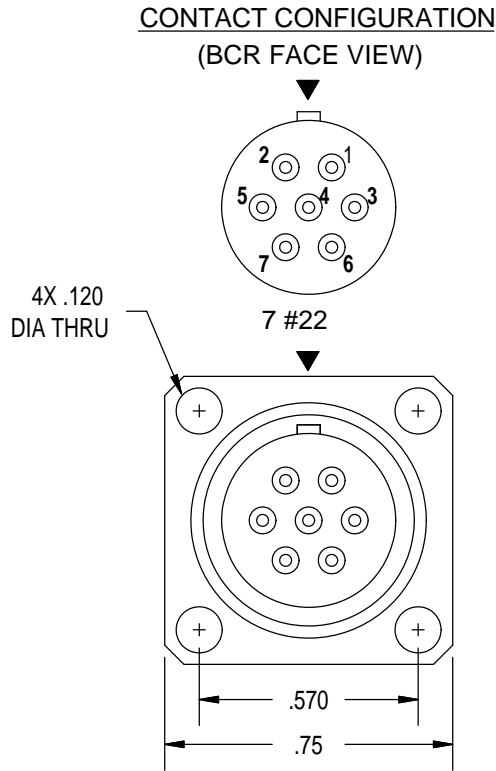

MOUNTING TORQUE FOR BCR	not to exceed 50 in lbs	MATED PRESSURE RATING (psi)	10,000
-------------------------	-------------------------	-----------------------------	--------

See pg. 9580 for SCP/SCR information.

NOTE: CCP is not terminated to cable unless specified.

* Please specify number of contacts.

** Internal assembly same as MKS(W)-3* -BCR (facing page).

*** Blind tapped hole not to penetrate bulkhead, minimum full thread depth 2 times bolt diameter.

MKS(W)-3L10

METAL KEY WET PLUGGABLE RUBBER MOLDED
TITAN™ SERIES

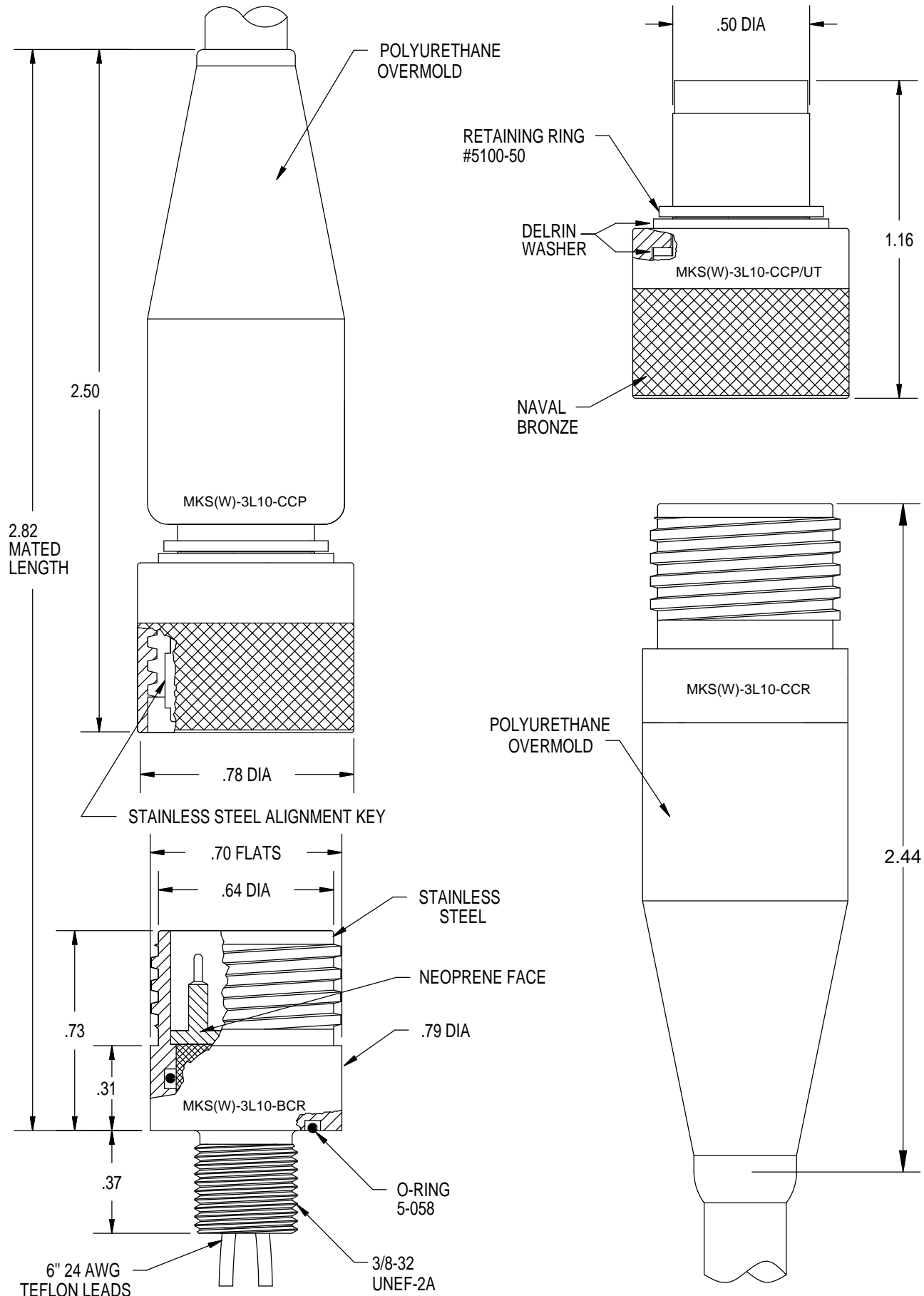

MKS(W)-3L10

METAL KEY WET PLUGGABLE RUBBER MOLDED
TITAN SERIES

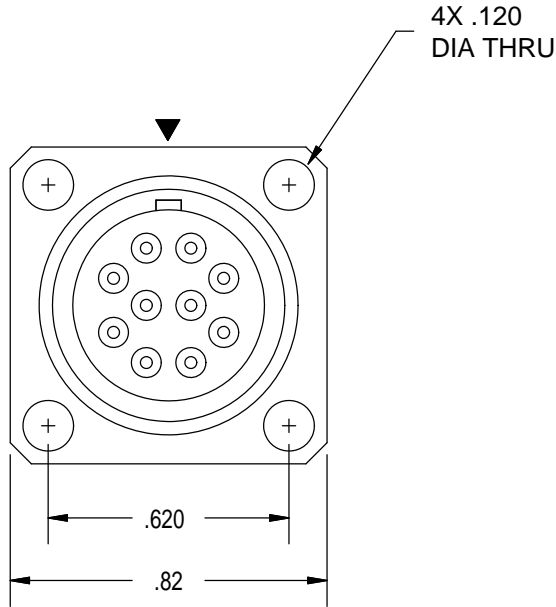

CONTACT CONFIGURATION (BCR FACE VIEW)

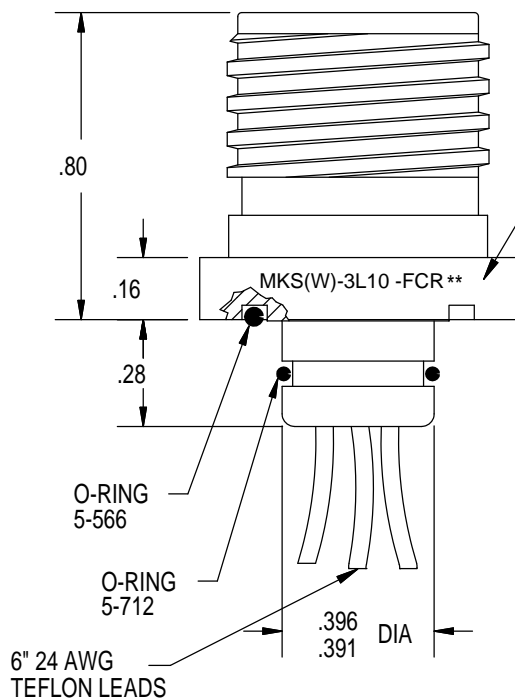
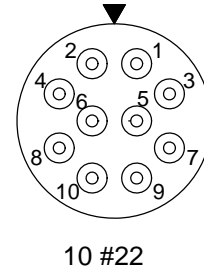

STAINLESS STEEL

MOUNTING INSTRUCTIONS

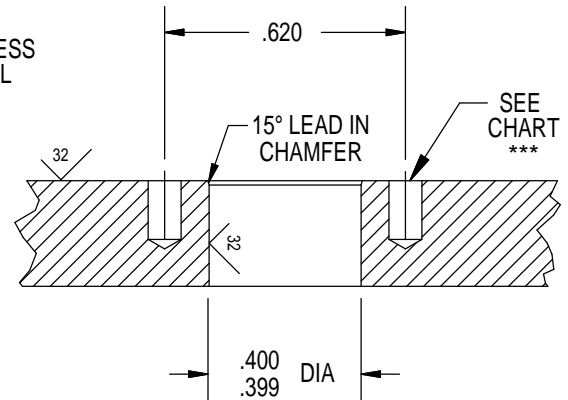

MOUNTING TORQUE FOR BCR	not to exceed 50 in lbs	MATED PRESSURE RATING (psi)	10,000
<p>NOTE: CCP is not terminated to cable unless specified.</p> <p>* Please specify number of contacts.</p> <p>**Internal assembly same as MKS(W)-3L10-BCR (facing page).</p> <p>*** Blind tapped hole not to penetrate bulkhead, minimum full thread depth 2 times bolt diameter.</p>			

MKS(W)-3XL

METAL KEY WET PLUGGABLE RUBBER MOLDED
TITAN™ SERIES

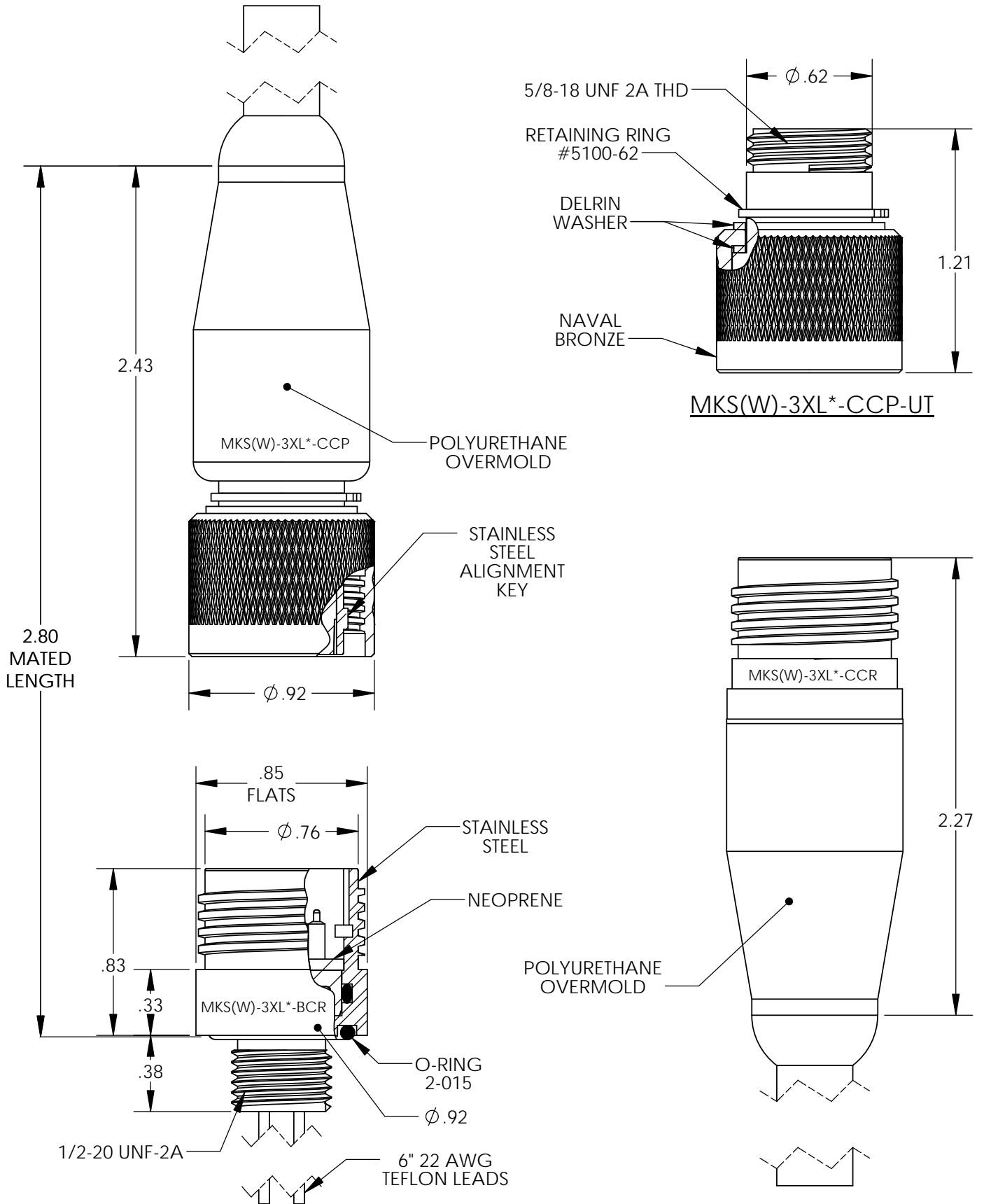

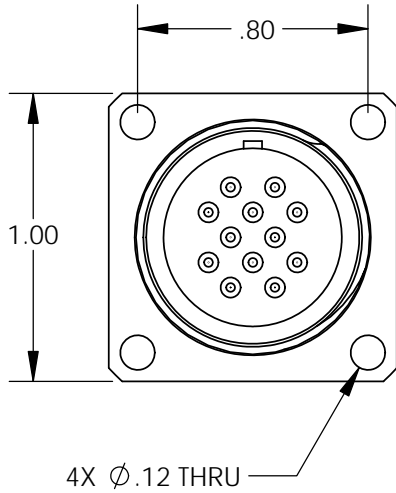

CONTACT CONFIGURATION
(BCR FACE VIEW)

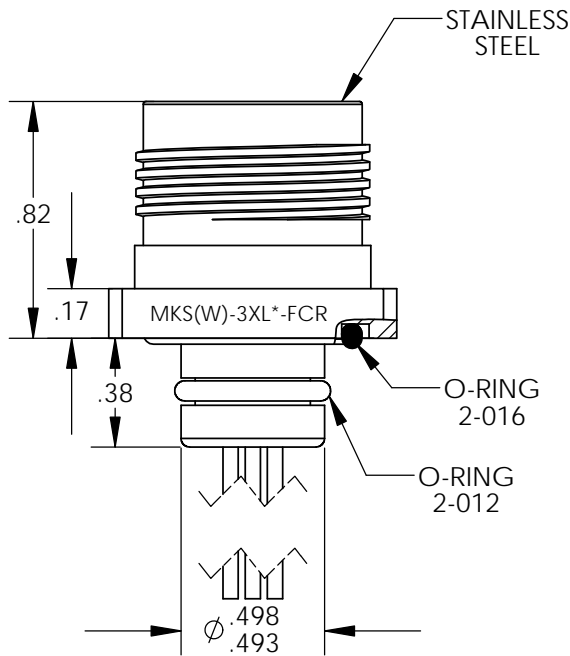
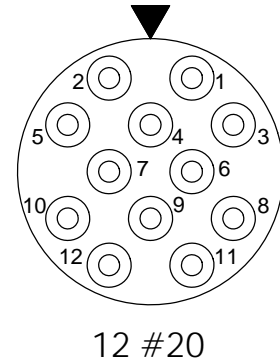

MOUNTING INSTRUCTIONS

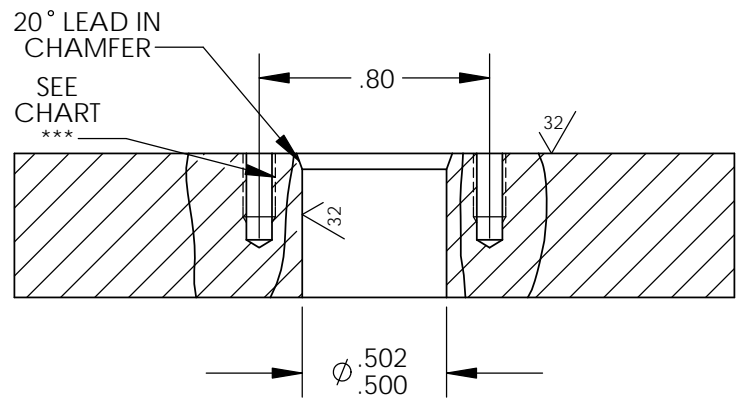

MOUNTING TORQUE FOR BCR	not to exceed 50 in lbs	MATED PRESSURE RATING (psi)	10,000
<p>NOTE: CCP is not terminated to cable unless specified.</p> <p>* Please specify number of contacts.</p> <p>**Internal assembly same as MKS(W)-3XL*-BCR (facing page).</p> <p>*** Blind tapped hole not to penetrate bulkhead, minimum full thread depth 2 times bolt diameter.</p>			

MKS(W)-4

METAL KEY WET PLUGGABLE RUBBER MOLDED TITAN™ SERIES

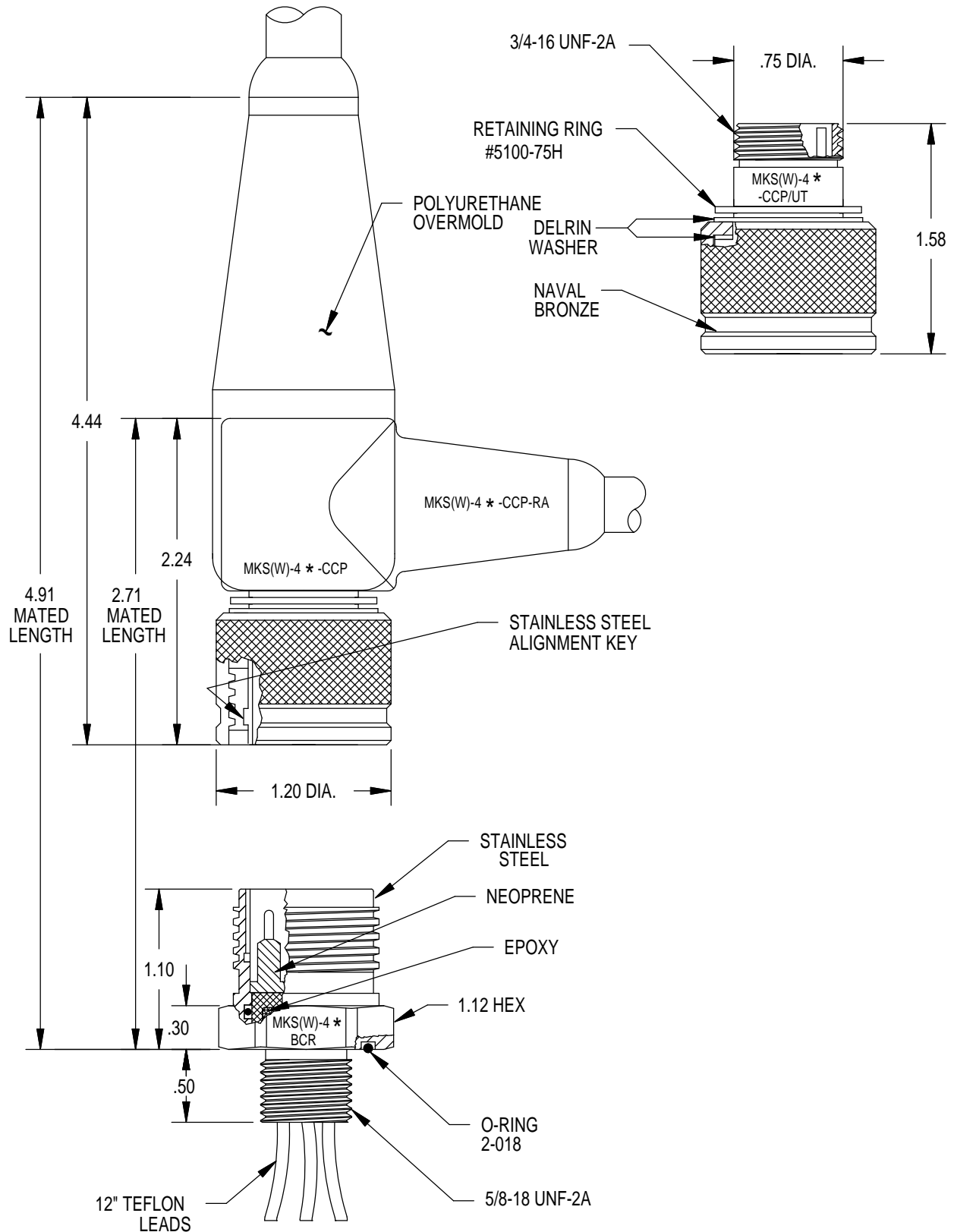

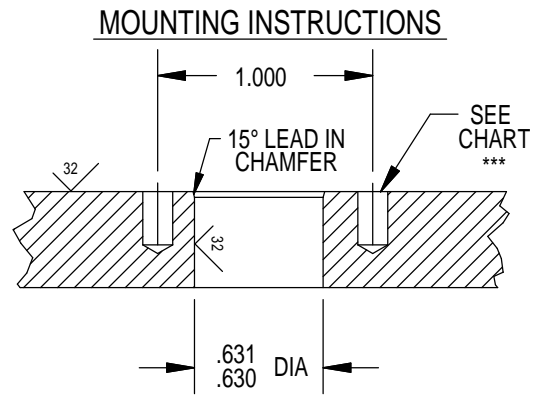
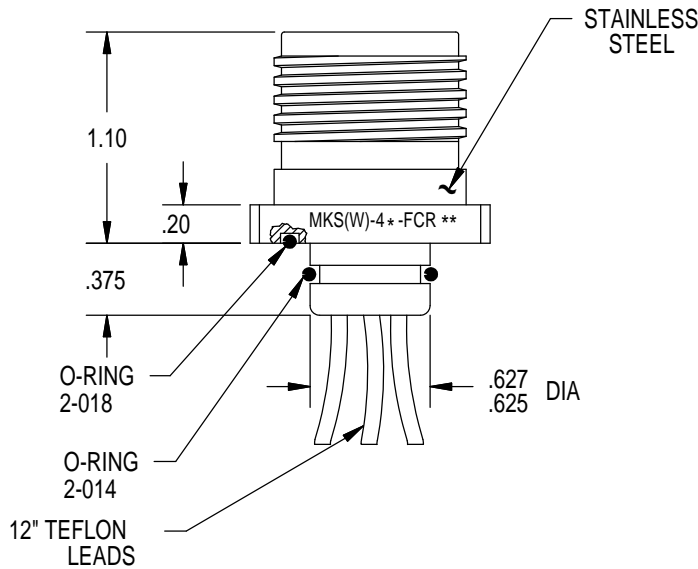
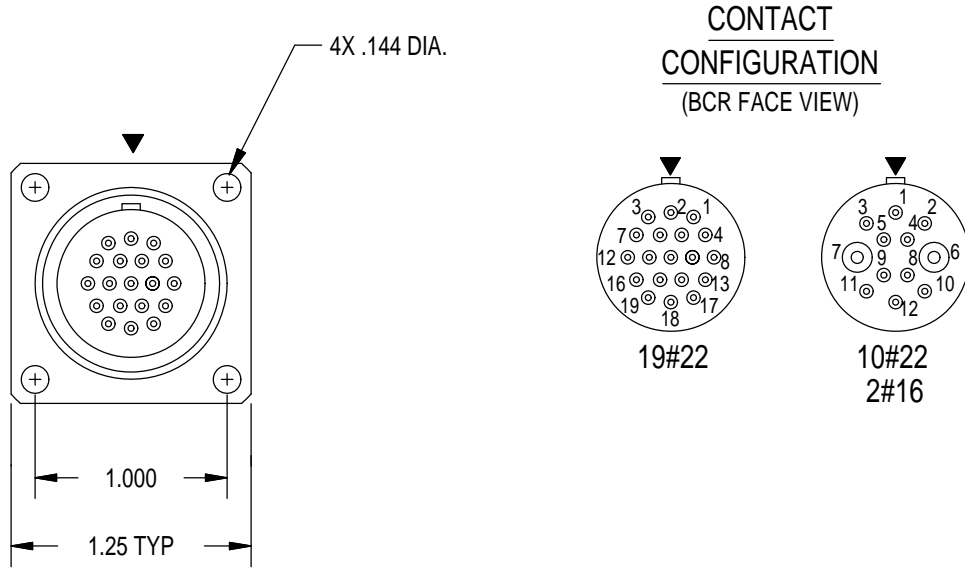

MOUNTING TORQUE FOR BCR	not to exceed 100 in lbs	MATED PRESSURE RATING (psi)	10,000
See pg. 9580 for SCP/SCR information.			
<p>NOTE: CCP is not terminated to cable unless specified.</p> <p>* Please specify number of contacts.</p> <p>** Internal assembly same as MKS(W)-4* -BCR (facing page).</p> <p>*** Blind tapped hole not to penetrate bulkhead, minimum full thread depth 2 times bolt diameter.</p>			

MKS(W)-5

METAL KEY WET PLUGGABLE RUBBER MOLDED TITAN™ SERIES

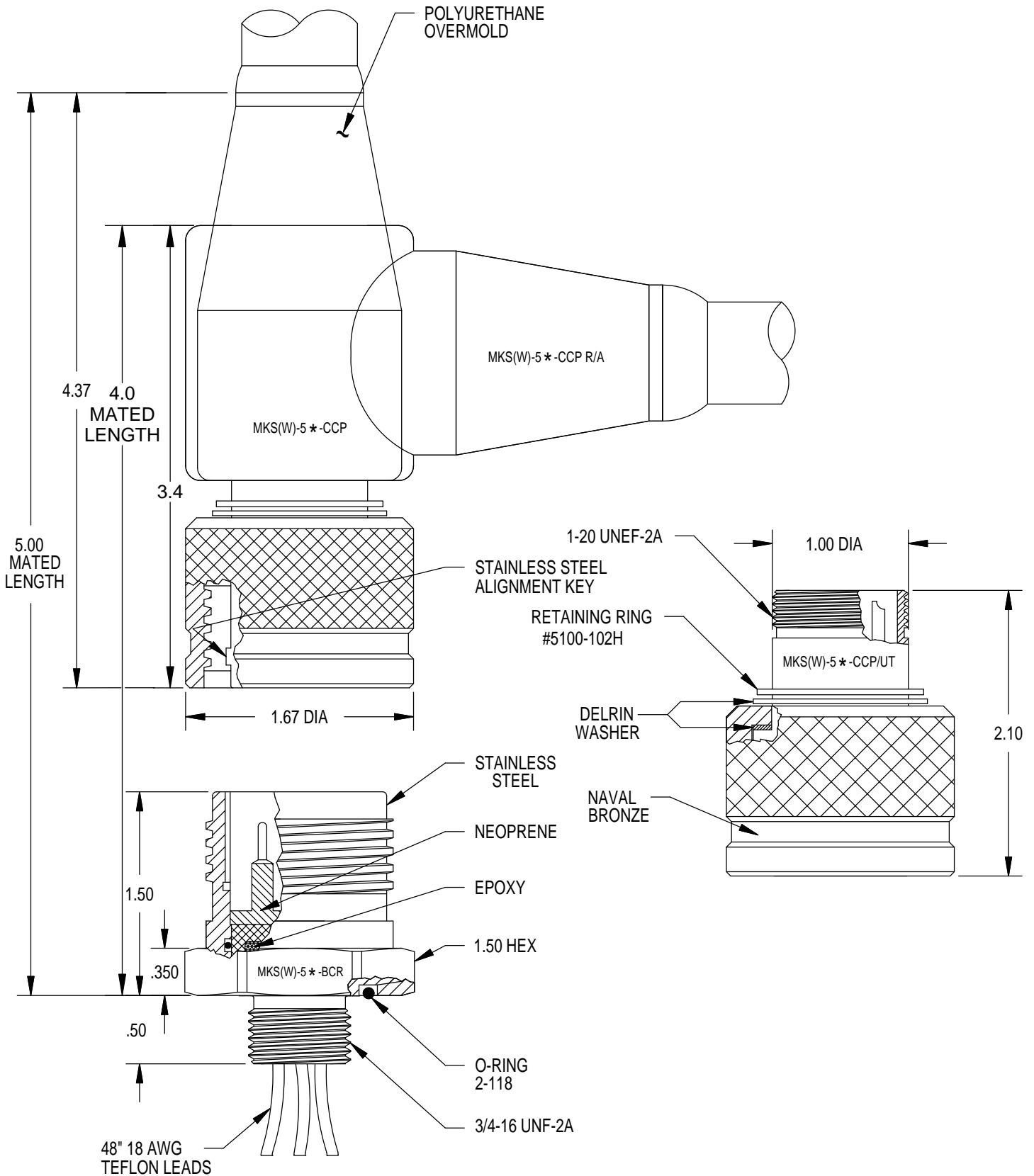

MKS(W)-5

METAL KEY WET PLUGGABLE RUBBER MOLDED TITAN™ SERIES

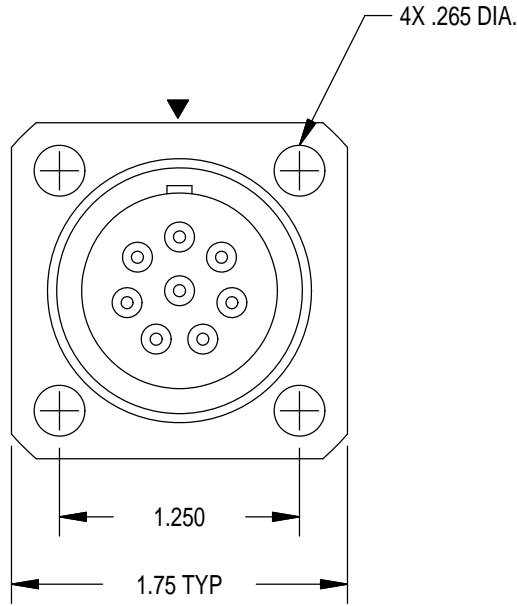

CONTACT CONFIGURATIONS (BCR FACE VIEW)

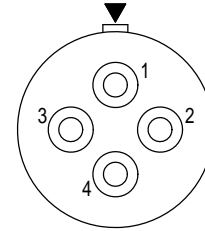

4#10

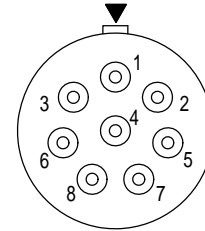

8#16

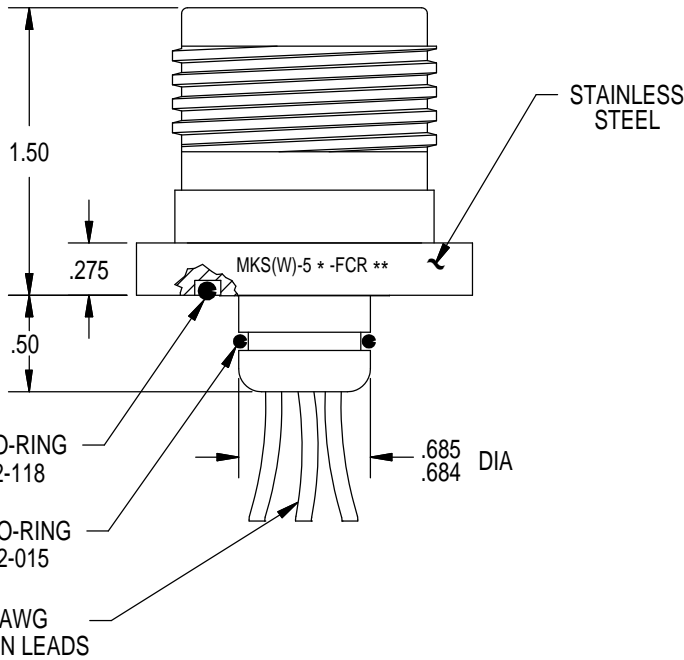

MOUNTING INSTRUCTIONS

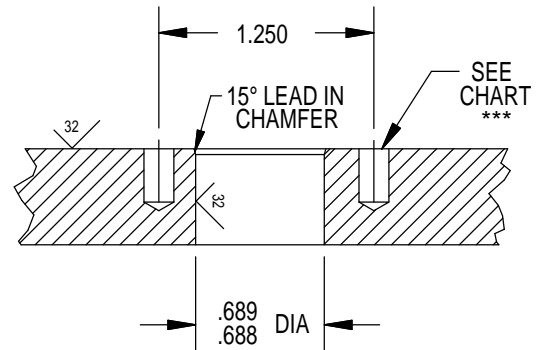

MOUNTING TORQUE FOR BCR	not to exceed 165 in lbs	MATED PRESSURE RATING (psi)	10,000
-------------------------	--------------------------	-----------------------------	--------

See pg. 9580 for SCP/SCR information.

NOTE: CCP is not terminated to cable unless specified.

* Please specify number of contacts.

** Internal assembly same as MKS(W)-5* -BCR (facing page).

*** Blind tapped hole not to penetrate bulkhead, minimum full thread depth 2 times bolt diameter.

MKS(W)-7

METAL KEY WET PLUGGABLE RUBBER MOLDED TITAN™ SERIES

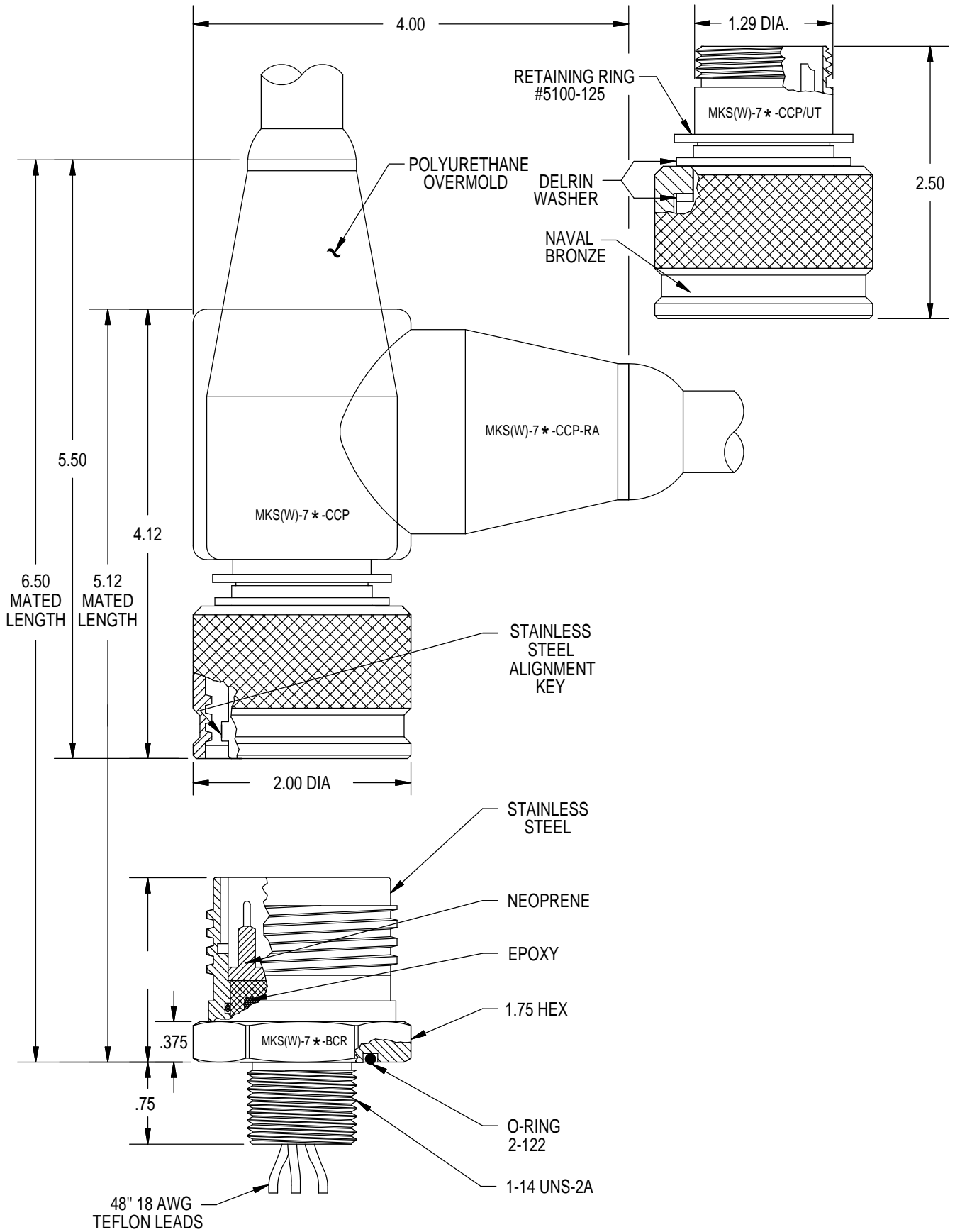

MKS(W)-7

METAL KEY WET PLUGGABLE RUBBER MOLDED TITAN™ SERIES

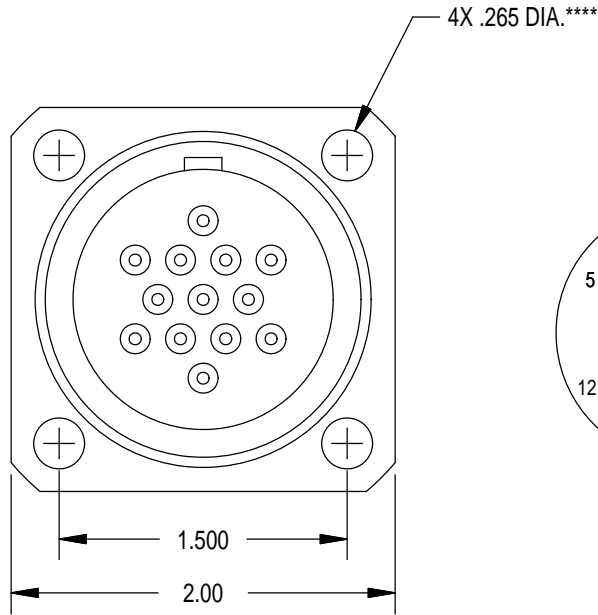

CONTACT CONFIGURATION (BCR FACE VIEW)

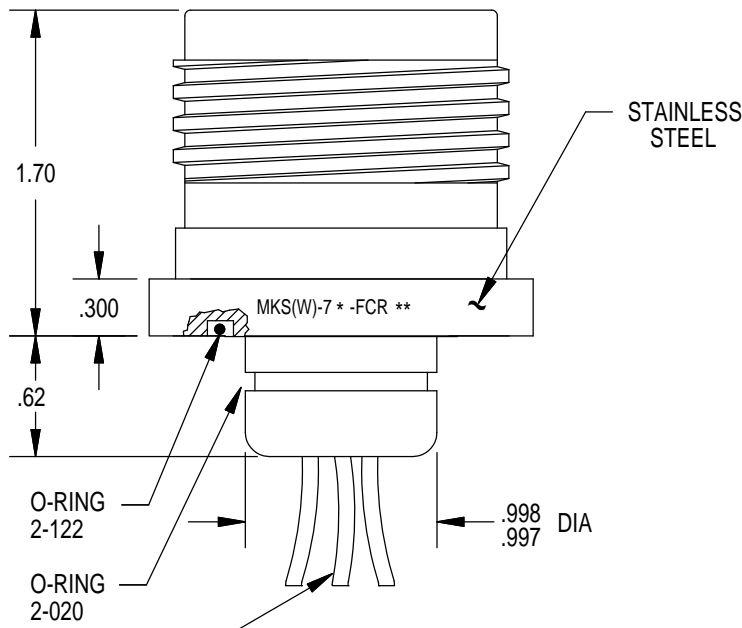
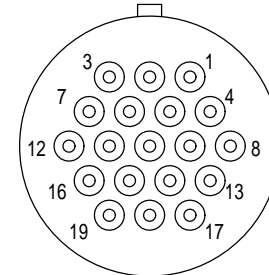
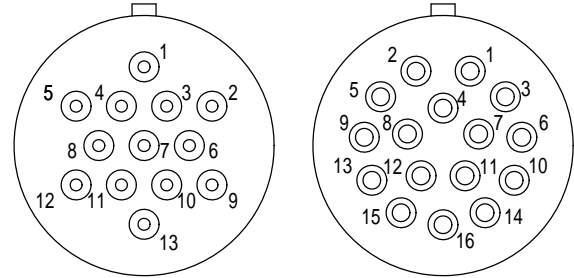

MOUNTING INSTRUCTIONS

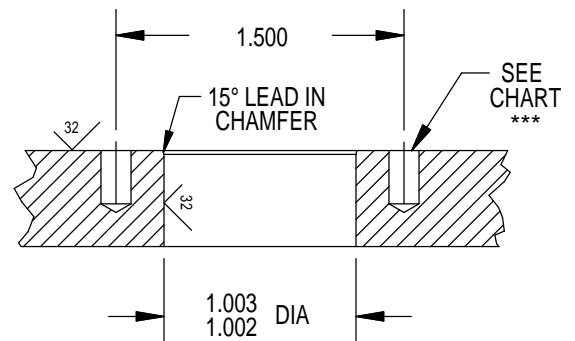

48" 18 AWG
TEFLON LEADS

MOUNTING TORQUE FOR BCR	not to exceed 225 in lbs	MATED PRESSURE RATING (psi)	10,000
See pg. 9580 for SCP/SCR information.			
<p>NOTE: CCP is not terminated to cable unless specified.</p> <p>* Please specify number of contacts.</p> <p>** Internal assembly same as MKS(W)-7* -BCR (facing page).</p> <p>*** Blind tapped hole not to penetrate bulkhead, minimum full thread depth 2 times bolt diameter.</p> <p>**** Modified M6 socket head cap bolts are available.</p>			

MKS(W)-9

METAL KEY WET PLUGGABLE RUBBER MOLDED TITAN™ SERIES

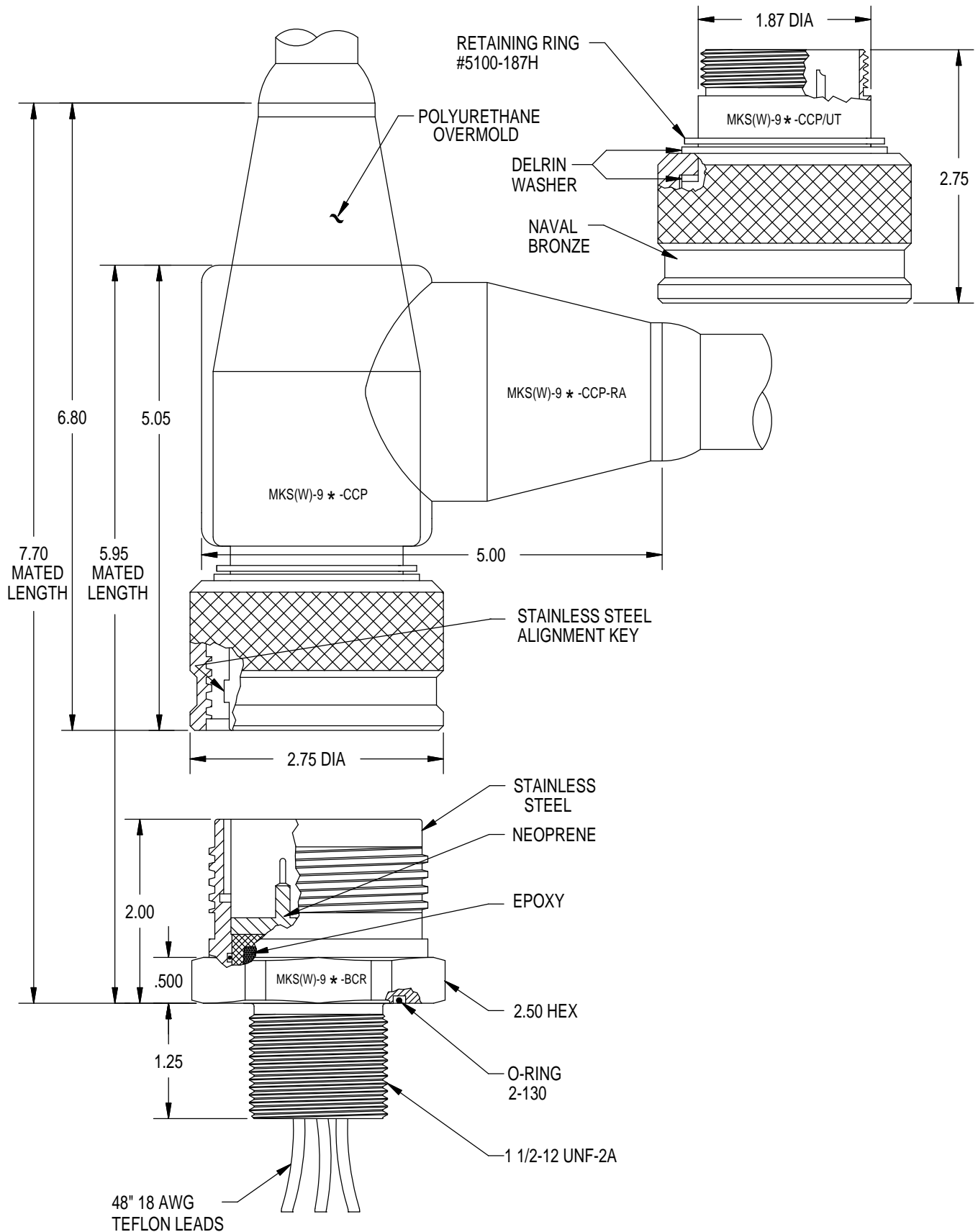

MKS(W)-9

METAL KEY WET PLUGGABLE RUBBER MOLDED TITAN™ SERIES

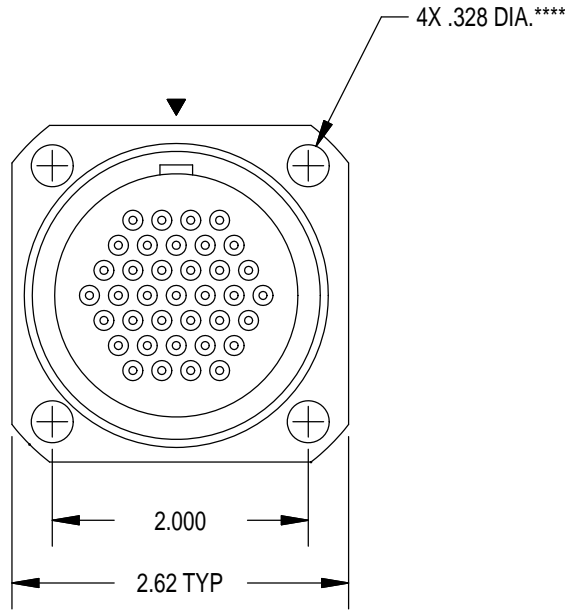

CONTACT CONFIGURATION (BCR FACE VIEW)

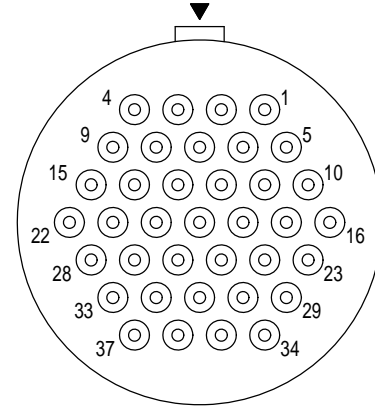

37#16

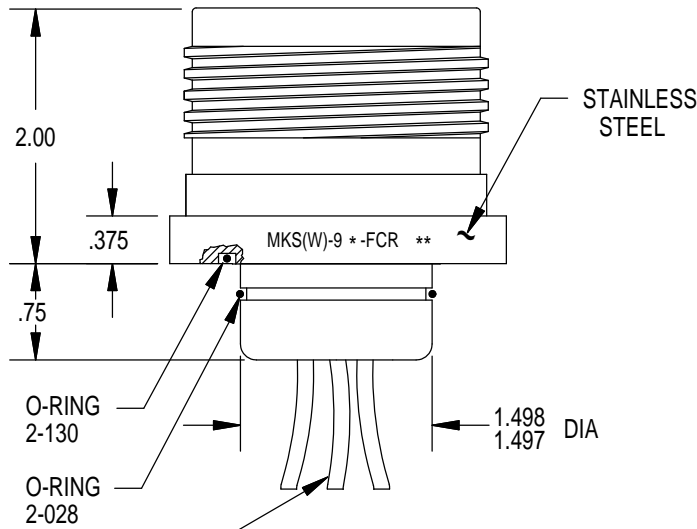

48" 18 AWG
TEFLON LEADS

MOUNTING INSTRUCTIONS

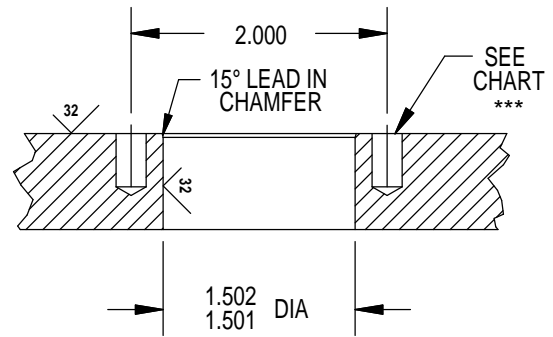

MOUNTING TORQUE FOR BCR	not to exceed 335 in lbs	MATED PRESSURE RATING (psi)	10,000
See pg. 9580 for SCP/SCR information.			
<p>NOTE: CCP is not terminated to cable unless specified.</p> <p>* Please specify number of contacts.</p> <p>** Internal assembly same as MKS(W)-9 * -BCR (facing page).</p> <p>*** Blind tapped hole not to penetrate bulkhead, minimum full thread depth 2 times bolt diameter.</p> <p>**** Modified M8 socket head cap bolts are available.</p>			

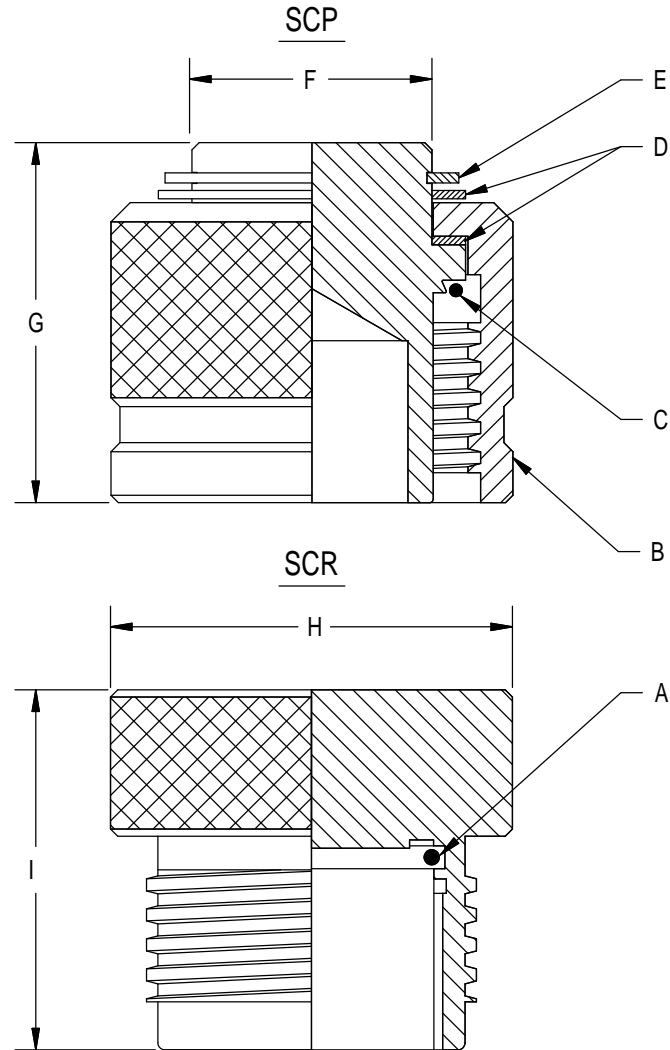

CONNECTOR SIZE	MKS-200	MKS-300	MKS-400	MKS-500	MKS-700	MKS-900
A O-RING	5-712	5-682	2-018	2-022	2-028	2-032
B ENGAGING NUT	452110	453115	462525	472527	482623	483107
C O-RING	5-057	5-682	5-003	2-023	2-028	2-033
D DELRIN WASHER(2X)	452101	453001	462530	472501	482618	483101
E RETAINING RING	5100-37	5100-43	5100-75	5100-102	5100-125	5100-187
F DIA	.37	.44	.76	1.00	1.29	1.87
G	.65	.75	1.15	1.50	1.87	2.00
H DIA	.60	.71	1.20	1.67	2.00	2.67
I	.58	.75	1.10	1.50	1.60	2.10
SCR MATED PRESSURE RATING(psi)	10,000	10,000	10,000	2,000	2,000	1,000
SCP MATED PRESSURE RATING(psi)	10,000	10,000	10,000	10,000	10,000	10,000
* Metal shell SCP/SCR are not wet pluggable						
** 10,000 psi rated wet pluggable dummies available upon request.						
*** MKS-300-SCP LP (50 psi) available upon request.						
**** MKS(W)-3L10 uses wet pluggable dummies only.						

CONNECTOR TERMINOLOGY

CONNECTOR TERMINOLOGY

BC	Bulkhead connector, no locking sleeve	FS	Female socket, neoprene standard has sockets, inverted has pins
BCL	Bulkhead connector locking, glass reinforced epoxy, with locking sleeve thread	FSD HP	Female socket, dummy, high pressure (>4000PSI), neoprene
BCP	Bulkhead connector plug, glass reinforced epoxy, mates with CCR	FSD LP	Female socket, dummy, low pressure (<4000PSI), neoprene
BCR	Bulkhead connector receptacle, glass reinforced epoxy or metal shell, mates with CCP	*-FLS-P	Female locking sleeve, nylon, for RM* or VM* connectors. * defines size of locking sleeve
BH	Bulkhead receptacle, wet pluggable series, neoprene with brass or stainless steel body	*-FLS-S	Female locking sleeve, stainless steel for RM* or VM* connectors. * defines size of locking sleeve
CCP	Cable connector plug, glass reinforced epoxy or metal shell, can be terminated to cable with neoprene or polyurethane overmold, mates with BCR, FCR, CCR	HD	Heavy duty or high density, depending on connector series
CCR	Cable connector receptacle, glass reinforced epoxy or metal shell, can be terminated to cable with neoprene or polyurethane overmold, mates with BCP, CCP	HP	High pressure
CIP	Contact insert plug, glass reinforced epoxy insert, used in metal shell BCP, CCP	HV	High voltage
CIR	Contact insert receptacle, glass reinforced epoxy insert, used in metal shell BCR, CCR, FCR	IE	Underwater pluggable series
DC	Dummy connector, neoprene, wet pluggable series	IE55	Rubber molded metal shell series
DLS*/F	Delrin locking sleeve, female, wet pluggable series. * defines size of locking sleeve	IE55V	Inverted rubber molded metal shell series
DLS*/M	Delrin locking sleeve, male, wet pluggable series. * defines size of locking sleeve	IE55W	Wet pluggable IE55 subminiature series
DSP	Dummy sealing plug, glass reinforced epoxy, stainless steel or aluminum, dummies off BCR, FCR, CCR	IERD	Underwater pluggable right angle bulkhead connector, neoprene, 1 pin/socket, 2 contacts
DSR	Dummy sealing receptacle, glass reinforced epoxy, stainless steel or aluminum, dummies off BCP, CCP	IESQ	Underwater pluggable connector, neoprene, 2 pins/sockets, 2 or 4 contacts
FCR	Flange connector receptacle, metal shell, mates with CCP	IL	Inline, neoprene, wet pluggable series
FIB	Field installable boot, neoprene, special type of RM* or VM* connector	LP	Low pressure
		LPBH	Low profile bulkhead connector, neoprene, wet pluggable series
		LPDC	Low profile dummy connector, neoprene, wet pluggable series
		LPIL	Low profile inline connector, neoprene, wet pluggable series
		LPMBH	Low profile mini bulkhead connector, neoprene, wet pluggable series
		LPMDC	Low profile mini dummy connector, neoprene, wet pluggable series

CONNECTOR TERMINOLOGY

LPMIL	Low profile mini inline connector, neoprene, wet puggable series	MPD LP	Male plug dummy, low pressure, (<4000PSI), neoprene
MBH	Mini bulkhead connector, neoprene, wet puggable series	MSA*	Metal shell aluminum, * defines shell size
MCBH	Micro mini bulkhead connector, neoprene, wet puggable series	MSS*	Metal shell stainless steel, * defines shell size
MCBH (WB)	Micro mini bulkhead connector, waterblocked, neoprene, wet puggable series	OF	Oil filled, CCP with stainless steel shell and adapter or glass reinforced epoxy with extended body
MCDC	Micro mini dummy connector, neoprene, wet puggable series	OM	Overmold, neoprene, field installable version of wet puggable series
MCDLS/*	Micro mini Delrin locking sleeve, wet puggable series, * designates male (M) or female (F)	P	Plastic, nylon
MCIL	Micro mini inline connector, neoprene, wet puggable series	PBC	Pigtail bulkhead connector, glass reinforced epoxy, no locking sleeve available, inboard leads
MDC	Mini dummy connector, neoprene, wet puggable series	PBCL	Pigtail bulkhead connector locking, glass reinforced epoxy, locking sleeve available, inboard leads
MHD*	Miniature high density metal shell connector. * defines size of connector	PBCLM	Pigtail bulkhead connector, locking mounting, glass reinforced epoxy, face seal, locking sleeve available, inboard leads
MIL	Mini inline connector, neoprene, wet pluggable series	PBH/PIL	Bulkhead receptacle, wet pluggable series, polyurethane with brass or stainless steel body
MKA	Metal key Titan connector, aluminum	PBOF	Pressure balanced oil filled
MKA(W)	Metal key Titan connector, aluminum wet pluggable	PC	Protective Cap
MKS	Metal key Titan connector, stainless steel	PIL	Inline, polyurethane, wet pluggable series
MKS(W)	Metal key Titan connector, stainless steel, wet pluggable	PNA	Penetrator, aluminum or stainless steel body, neoprene or polyurethane overmold, water blocked using glass reinforced epoxy insert
-MLS-P	Male locking sleeve, nylon, for RM or VM* connectors, * defines size of locking sleeve	RA	Right angle
-MLS-S	Male locking sleeve, stainless steel, for RM or VM* connectors, * defines size of locking sleeve	RM*	Rubber molded connector, * defines size of connector
MOM	Mini overmold connector, neoprene, field installable version of wet pluggable series	RM*-BCL	Stainless steel bulkhead connector, mates with RM*-FS connector, * defines size of connector
MP	Male plug, neoprene, standard has pins, inverted has sockets	RMH	Rubber molded hermaphrodite, 1 pin + 1 socket
MPD HP	Male plug dummy, high pressure, (>4000PSI), neoprene	S OR SS	Stainless steel

CONNECTOR TERMINOLOGY

SCP Sealing cap plug, glass reinforced epoxy, stainless steel or aluminum, dummies off BCR, FCR and CCR

SCR Sealing cap receptacle, glass reinforced epoxy, stainless steel or aluminum, dummies off BCP, CCP

SL Rubber molded slip on connector, RMA and VMA only

UT Unterminated

VM* Inverted rubber molded connector, * defines size of connector

VM*-BCL Inverted stainless steel bulkhead connector, mates with VM*-FS connector, * defines size of connector

VS* Inverted glass reinforced epoxy connector, mates with VM*-FS connector, * defines size of connector

XP Extended plastic locking sleeve

XS* Glass reinforced epoxy connector, * defines size of connector

CONNECTOR INDEX

INDEX

Part #	Technical Bulletin	Part #	Technical Bulletin	Part #	Technical Bulletin
-A-					
A-M/FLS-P/S	20 40	IE2F-7/16-DO	75 62	IE55-15XX-CCP UT	70 10
AG206-FS	20 23	IE2F-BC	75 10	IE55-15XX-CCR	70 10
AG206-MP	20 23	IE2M-5/8	75 10	IE55-15XX-CCP UT	70 10
AG306-FS	20 23	IE2M-7/16	75 20	IE55-15XX-CCR	70 10
AG306-HP-SS	20 23	IE2M-5/8-DO	75 62	IE55-15XX-FCR	70 11
		IE2M-7/16-DO	75 62	IE55-20XX-BCR	70 20
-B-					
BH-2/3/4/5-FS	65 10	IE2M-BC	75 10	IE55-20XX-CCP	70 20
BH-2/3/4/5-FS/MP EXT	65 36	IE31F-5/8	75 80	IE55-20XX-CCP R/A	70 21
BH-2/3/4/5-MP	65 10	IE31F-5/8-DO	75 110	IE55-20XX-CCP UT	70 20
BH-6/8-FS	65 20	IE31F-BC	75 80	IE55-20XX-CCR	70 20
BH-6/8-MP	65 20	IE31M-5/8	75 80	IE55-20XX-FCR	70 21
BH-6/8-FS/MP EXT	65 37	IE31M-5/8-DO	75 110	IE55-24XX-BCR	70 30
BH-12-FS	65 30	IE31M-7/16	75 80	IE55-24XX-CCP	70 30
BH-12-MP	65 30	IE31M-BC	75 80	IE55-24XX-CCP R/A	70 31
		IE32/33F	75 81	IE55-24XX-CCP UT	70 30
		IE32/33F-BC	75 81	IE55-24XX-CCR	70 30
		IE32/33F-DO	75 110	IE55-24XX-FCR	70 31
		IE32/33M	75 81	IE55-32XX-BCR	70 40
		IE32/33M-BC	75 81	IE55-32XX-CCP	70 40
		IE32/33M-DO	75 110	IE55-32XX-CCP R/A	70 41
		IE34F	75 82	IE55-32XX-CCP UT	70 40
		IE34F-BC	75 82	IE55-32XX-CCR	70 40
		IE34F-DO	75 111	IE55-32XX-FCR	70 41
		IE34M	75 82	IE55(V)-20XX-BCR	71 10
		IE34M-DO	75 111	IE55(V)-20XX-CCP	71 10
		IE34M-BC	75 82	IE55(V)-20XX-CCP R/A	71 11
		IE4F	75 40	IE55(V)-20XX-CCP UT	71 10
		IE4F-BC	75 40	IE55(V)-20XX-CCR	71 10
		IE4F-DO	75 63	IE55(V)-20XX-FCR	71 11
		IE4M	75 40	IE55(V)-24XX-BCR	71 20
		IE4M-BC	75 40	IE55(V)-24XX-CCP	71 20
		IE4M-DO	75 63	IE55(V)-24XX-CCP R/A	71 21
		IE55-12XX-BCR	70 05	IE55(V)-24XX-CCP UT	71 20
		IE55-12XX-CCP	70 05	IE55(V)-24XX-CCR	71 20
		IE55-12XX-CCP R/A	70 05	IE55(V)-24XX-FCR	71 21
		IE55-12XX-CCP UT	70 05	IE55(W)-10XX-BCR	70 03
		IE55-12XX-CCR	70 05	IE55(W)-10XX-CCP	70 03
		IE55-12XX-FCR	70 06	IE55(W)-10XX-CCP R/A	70 03
		IE55-15XX-BCR	70 10	IE55(W)-10XX-CCP UT	70 03
		IE55-15XX-CCP	70 10	IE55(W)-10XX-CCR	70 03
		IE55-15XX-CCP R/A	70 11	IE55(W)-10XX-FCR	70 04
-I-					
IE2F-5/8	75 10				
IE2F-5/8-DO	75 62				

INDEX

Part #	Technical Buletin	Part #	Technical Buletin	Part #	Technical Buletin
IE6/8F	75 50	IESQ4F/M-BC	75 30	LPIL-7-FS	65 60
IE6/8F-BC	75 50	IESQ4F/M-DO	75 62	LPIL-7-MP	65 60
IE6/8F-DO	75 63	IESQ4M	75 31	LPIL-9/12-FS	65 70
IE6/8M	75 50	IESQ4M-BC	75 30	LPIL-9/12-MP	65 70
IE6/8M-BC	75 50	IESQ4M-DO	75 62	LPMBH-FS	65 81
IE6/8M-DO	75 63	IESQ4SW	80 20	LPMBH-MP	65 81
IE66-3204-BCR	71 30	IL-2/3/4/5-FS	65 10	LPMDC-FS	65 83
IE66-3204-CCP	71 30	IL-2/3/4/5-MP	65 10	LPMDC-MP	65 83
IE66-3204-CCP R/A	71 31	IL-6/8-FS	65 20	LPMIL-FS	65 81
IE66-3204-CCP UT	71 30	IL-6/8-MP	65 20	LPMIL-MP	65 81
IE66-3204-CCR	71 30	IL-12-FS	65 30	LSG-BC	20 25
IE66-3204-FCR	71 31	IL-12-MP	65 30	LSG-BC HP	20 25
IEB2F	77 55			LSG-BCL	20 24
IEB2F-DO	75 62				
IEB2M	75 55	-K-		-M-	
IEB2M-DO	75 62	K-M/FLS-P/S	20 40	MBH-7/9-FS	65 85
IEB34F	75 90	K-FLS-XP	20 41	MBH-7/9-MP	65 85
IEB34F-DO	75 111			MBH-12/16-FS	65 90
IEB34M	75 90			MBH-12/16-MP	65 90
IEB34M-DO	75 111	-L-		MBH-18-FS	65 95
IEB6/8F	75 60	LMG-FS	20 24	MBH-18-MP	65 95
IEB6/8F-DO	75 63	LMG-FS R/A	20 24	MCBH-2/3/4-FS	65 110
IEB6/8M	75 60	LMG-MP	20-24	MCBH-2/3/4-MP	65 110
IEB6/8M-DO	75 63	LPBH-2-FS	65 40	MCBH-5/6/8-FS	65 120
IEB-6/8-FLS	75 61	LPBH-2-MP	65 40	MCBH-5/6/8-MP	65 120
IEB-6/8-MLS	75 61	LPBH-3/4/5-FS	65 50	MCBH-10/12/16/18-FS	65 122
IERD2F-BC	75 20	LPBH-3/4/5-MP	65 50	MCBH-10/12/16/18-MP	65 122
IERD2M-BC	75 20	LPBH-7-FS	65 60	MCDC-2/3/4/5/6/8-FS	65 125
IESQ32F	75 101	LPBH-7-MP	65 60	MCDC-2/3/4/5/6/8-MP	65 125
IESQ32F-BC	75 100	LPBH-9/12-FS	65 70	MCDC-10/12/16/18-FS	65 126
IESQ32F-DO	75 112	LPBH-9/12-MP	65 70	MCDC-10/12/16/18-MP	65 126
IESQ32M	75 101	LPDC-2/3/4/5-FS	65 71	MCDLS-F	65 111
IESQ32M-BC	75 100	LPDC-2/3/4/5-MP	65 71	MCDLS-M	65 111
IESQ32M-DO	75 112	LPDC-7-FS	65 72	MCIL-2/3/4-FS	65 110
IESQ32M/F	75 101	LPDC-7-MP	65 72	MCIL-2/3/4-MP	65 110
IESQ32M/F-BC	75 100	LPDC-9/12-FS	65 73	MCIL-5/6/8-FS	65 120
IESQ32M/F-DO	75 112	LPDC-9/12-MP	65 73	MCIL-5/6/8-MP	65 120
IESQ4F	75 31	LPIL-2-FS	65 40	MCIL-10/12/16/18-FS	65 122
IESQ4F-BC	75 30	LPIL-2-MP	65 40	MCIL-10/12/16/18-MP	65 122
IESQ4F-DO	75 62	LPIL-3/4/5-FS	65 50	MCBH(WB)-2/3/4-FS	66 05
IESQ4F/M	75 31	LPIL-3/4/5-MP	65 50	MCBH(WB)-2/3/4-MP	66 05

INDEX

Part #	Technical Bulletin	Part #	Technical Bulletin	Part #	Technical Bulletin
MCBH(WB)-2/3/4-FS R/A	66 06	MHDL-FCR	85 31	MKS-310-CCP UT	95 05
MCBH(WB)-2/3/4-MP R/A	66 06	MHDL-SCP	85 65	MKS-310-CCR	95 05
MCBH(WB)-5/6/8-FS	66 11	MHDL-SCR	85 65	MKS-310-FCR	95 06
MCBH(WB)-5/6/8-MP	66 11	MHDM-BCR	85 40	MKS(W)-204-BCR	95 31
MCBH(WB)-5/6/8-FS R/A	66 12	MHDM-FCR	85 41	MKS(W)-204-CCP	95 31
MCBH(WB)-5/6/8-MP R/A	66 12	MHDM-CCP	85 40	MKS(W)-204-CCP R/A	95 32
MCIL(WB)-2/3/4-FS	66 05	MHDM-CCP R/A	85 40	MKS(W)-204-CCP UT	95 31
MCIL(WB)-2/3/4-MP	66 05	MHDM-SCP	85 65	MKS(W)-204-CCR	95 31
MCIL(WB)-5/6/8-FS	66 11	MHDM-SCR	85 65	MKS(W)-307-BCR	95 41
MCIL(WB)-5/6/8-MP	66 11	MHDO-BCR	85 50	MKS(W)-307-CCP	95 41
MCIL(WB)-2/3/4-FS R/A	66 06	MHDO-CCP	85 50	MKS(W)-307-CCP R/A	95 42
MCIL(WB)-2/3/4-MP R/A	66 06	MHDO-CCP R/A	85 50	MKS(W)-307-CCP UT	95 41
MCIL(WB)-5/6/8-FS R/A	66 12	MHDO-CCP OF	86 50	MKS(W)-307-CCR	95 41
MCIL(WB)-5/6/8-MP R/A	66 12	MHDO-CCR	85 50	MKS(W)-307-FCR	95 42
MCLPBH-9-FS	65 124	MHDO-FCR	85 51	MKS(W)-3L10-BCR	95 43
MCLPBH-9-MP	65 124	MHDO-SCP	85 65	MKS(W)-3L10-CCP	95 43
MCLPIL-9-FS	65 124	MHDO-SCR	85 65	MKS(W)-3L10-CCP UT	95 43
MCLPIL-9-MP	65 124	MHDR-BCR	85 60	MKS(W)-3L10-CCR	95 43
MCLPDC-9-FS	65 127	MHDR-CCP	85 60	MKS(W)-3L10-FCR	95 44
MCLPDC-9-MP	65 127	MHDR-FCR	85 61	MKS(W)-3XLXX-BCR	95 45
MCOM-2/3/4-FS	65 111	MHDR-SCP	85 65	MKS(W)-3XLXX-CCP	95 45
MCOM-2/3/4-MP	65 111	MHDR-SCR	85 65	MKS(W)-3XLXX-CCP UT	95 45
MCOM-5/6/8-FS	65 121	MIL-7/9-FS	65 85	MKS(W)-3XLXX-CCR	95 45
MCOM-5/6/8-MP	65 121	MIL-7/9/-MP	65 85	MKS(W)-3XLXX-FCR	95 46
MDC-7/9/12/16-FS	65 97	MIL-12/16-FS	65 90	MKS-400-SCP	95 80
MDC-7/9/12/16-MP	65 97	MIL-12/16-MP	65 90	MKS-400-SCR	95 80
MDC-18-FS	65 98	MIL-18-FS	65 95	MKS(W)-4XX-BCR	95 47
MDC-18-MP	65 98	MIL-18-MP	65 95	MKS(W)-4XX-CCP	95 47
MHDG-BCR	85 20	MKS-20X-BCR	95 03	MKS(W)-4XX-CCP R/A	95 47
MHDG-CCP	85 20	MKS-20X-CCP	95 03	MKS(W)-4XX-CCP UT	95 47
MHDG-CCP R/A	85 20	MKS-20X-CCP UT	95 03	MKS(W)-4XX-FCR	95 48
MHDG-CCP OF	86 20	MKS-20X-CCP R/A	95 04	MKS-500-SCP	95 80
MHDG-CCR	85 20	MKS-20X-CCR	95 03	MKS-500-SCR	95 80
MHDG-FCR	85 21	MKS-200-SCP	95 80	MKS(W)-5XX-BCR	95 50
MHDG-SCP	85 65	MKS-200-SCR	95 80	MKS(W)-5XX-CCP	95 50
MHDG-SCR	85 65	MKS-300-SCP	95 80	MKS(W)-5XX-CCP R/A	95 50
MHDL-BCR	85 30	MKS-300-SCP LP	95 80	MKS(W)-5XX-CCP UT	95 50
MHDL-CCP	85 30	MKS-300-SCR	95 80	MKS(W)-5XX-FCR	95 51
MHDL-CCP R/A	85 30	MKS-310-BCR	95 05	MKS-700-SCP	95 80
MHDL-CCP OF	86 30	MKS-310-CCP	95 05	MKS-700-SCR	95 80
MHDL-CCR	85 30	MKS-310-CCP R/A	95 06	MKS(W)-7XX-BCR	95 60

INDEX

Part #	Technical Buletin	Part #	Technical Buletin	Part #	Technical Buletin
-O-		-V-			
OM-2/3/4/5-FS	65 11	VMA-FS	25 10	XSE-CCP R/A	30 20
OM-2/3/4/5-MP	65 11	VMA-FS R/A	25 10	XSE-CCR	30 20
OM-6/8-FS	65 21	VMA-SL-FS	25 11	XSG-BCL	20 20
OM-6/8-MP	65 21	VMA-MP	25 10	XSG-BCL HP	20 20
OM-12-FS	65 31	VMA-SL-MP	25 11	XSG-BCL HP SS	20 22
OM-12-MP	65 31	VMF-FS	25 20	XSG-PBC	20 22
		VMF-FS R/A	25 20	XSG-PBCL	20 22
		VMF-MP	25 20	XSG-PBCLM	20 22
		VMG-BCL	25 30	XSJ-BCR	30 10
		VMG-FS	25 30	XSJ-CCP	30 10
		VMG-FS FIB	25 31	XSJ-CCP OF	30 10
		VMG-FS FIB W/LS	25 31	XSJ-CCP R/A	30 10
		VMG-FS R/A	25 30	XSJ-CCR	30 10
		VMG-MP	25 30	XSK-BCL	20 30
		VMG-MP FIB	25 31	XSL-BCP	30 31
		VMG-MP FIB W/LS	25 31	XSL-BCR	30 30
		VMK-BCL	25 41	XSL-CCP	30 30
		VMK-FS	25 40	XSL-CCP OF	30 31
		VMK-FS R/A	25 40	XSL-CCP R/A	30 30
		VMK-FS FIB	25 41	XSL-CCR	30 30
		VMK-MP	25 40	XSM-BCR	30 40
		VMK-MP FIB	25 41	XSM-CCP	30 40
		VSA-BC	25 10	XSM-CCP R/A	30 40
		VSA-BCL	25 10	XSM-CCR	30 40
		VSB-BCL	25 11		
		VSF-BCL	25 20		
		VSF-FLS-XP	25 50		
		VSG-BCL	25 30		
		VSG-BCL-HP SS	25 30		
		VSG-PBC	25 32		
		VSG-PBCL	25 32		
		VSG-PBCLM	25 32		
		VSK-BCL	25 40		
		-X-			
		XSA-BC	20 10		
		XSA-BCL	20 10		
		XSB-BCL	20 11		
		XSE-BCR	30 20		
		XSE-CCP	30 20		
-P-					
PNA 3/8"	55 11				
PNA 3/8" R/A	55 11				
PNA 1/2"	55 11				
PNA 1/2" R/A	55 11				
PNA 3/4"	55 10				
PNA 3/4" R/A	55 10				
PNA 1"	55 10				
PNA 1" R/A	55 10				
-R-					
RMA-FS	20 10				
RMA-FS R/A	20 10				
RMA-SL-FS	20 11				
RMA-MP	20 10				
RMA-SL-MP	20 11				
RMG-FS	20 20				
RMG-FS FIB	20 21				
RMG-FS FIB W/LS	20 21				
RMG-FS R/A	20 20				
RMG-MP	20 20				
RMG-MP FIB	20 21				
RMG-MP FIB W/LS	20 21				
RMH-2-FS/MP	65 130				
RMHDC-2-FS/MP	65 130				
RMK-FS	20 30				
RMK-FS FIB	20 31				
RMK-FS R/A	20 30				
RMK-MP	20 30				
RMK-MP FIB	20 31				
RSBH-2-FS	80 10				
RSIL-2-MP	80 10				

APPROVAL					
PREPARED BY	CHECKED BY	ENGINEERING	PRODUCTION	QUALITY	GENERAL MANAGER
Binh Le	Kathy Ring	Som Faramarzi	Dana Forseth	Debbie Micca	Ray Hom
Date: 02/02/2016	Date: 02/02/2016	Date: 02/02/2016	Date: 02/03/2016	Date: 02/03/2016	Date: 02/08/2016

REVISION HISTORY			
AUTHORITY	REV	DATE	DESCRIPTION
151009-01	2015-A	10/09/15	UPDATED SOLIDWORKS & RELEASED TECHNICAL MANUAL
160128-02	2016-A	02/08/16	UPDATED GENERAL INFORMATION SECTION